

2. Multilevel Modeling of VSI Fed PMSM Drive Systems

2.1 Modeling Approach

In the beginning of the modeling process, a designer must define some conventions related to the nature of the signal flowing through the model, and some standards about a module's graphical and functional designs. In this work, these conventions are:

1) The signals on the terminals of detailed and average models in stationary coordinates, connected to the main power circuit have electrical characteristics, i.e. they are described through their voltage and current vectors.

2) The signals on the terminals of average models designed in dq (or dq0) coordinates have unitless, single vector properties and they will be called control signals. They can come either from the other dq modules or from the interface blocks between electrical signals in stationary coordinates and control signals in dq coordinates. These terminals are defined to have unidirectional signal flow property (could be either inputs or outputs). Although Saber simulation software, which is used in this case, has the model of bi-directional control signal flow terminals, it was found to be impractical in this application.

3) The signals on the stationary average model terminals connected to the control circuits, like the terminals for the average phase duty cycle inputs of the VSI average model, have the control signal properties.

4) The signals on the detailed model terminals connected to the control circuits, like the terminals for the switching signals of the VSI detailed model, can be both, electrical or control signals, depending on a desired level of detail. Using the same example, the VSI switches can be modeled with the control switching signals, coming directly from the PWM modulator, or with the electrical switching signals coming from a D/A converter and a driver circuit. The ideal switch models with switching control signals are used for the purposes of this work.

5) The average models can be designed either using the equivalent electric circuit models or the control block schemes following their state-space mathematical models. Both approaches have their pros and cons. The "electrical" models have all the advantages of using the electric component models, which are usually available in the original software library, designed to the

certain level of detail, and with the possibility of various side-effect analyses, like temperature and robustness (regarding the parameter tolerances) analyses. On the other hand, the “control” models allow much faster simulations, because they contain only simple mathematical blocks. For the sake of simplicity, the latter models are applied in this work.

6) The graphical appearance and functionality of models were designed to follow the models from the original Saber and Matlab libraries.

A new, multilevel modeling approach for creating the simulation models of power electronic circuits based on the modular modeling principles is developed for easier analysis and faster simulations. A modeled system, like the PMSM drive, is divided into modules using the software ability of hierarchical modeling [16, 43], Figure 1. Each module can be modeled at various levels of complexity, which can be classified in three large modeling groups, according to the desired simulation analysis:

a) Detailed (switching) modeling. At this level, the modules are modeled as multiport electric circuits, i.e. the module terminals represent electrical connections that exist in a real circuit. The processes within a module are preferably modeled with circuit diagrams corresponding to a physical implementation. Depending on the desired level of accuracy, the models could be developed with several sub-levels of detail. For example, the VSI switching model can use ideal switches, or a complete model of a specific device [1, 5-7, 14, 15]. Models at this level allow the study of such phenomena as switching frequency current ripple, high-frequency spectrum, and parasitic oscillations. Because of the long simulation time, the analysis is usually focused within short time periods, i.e. several switching cycles. Sometimes, when more detailed information about transients is needed over a longer time period, time-extended simulations of detailed system models are inevitable.

b) Average (low-frequency) modeling. The modules are still modeled as multiport electric circuits, but the high-frequency (converter switching frequency and higher) effects are not considered. This means that the modules which contain switching functions (such as VSI and SVM modulator in Figure 1) are replaced with their low-frequency average counterparts, and that parasitic passive components (L, C, R) are not included in any of these models. Modeling at this level allows realistic analysis of large-signal transients, including salient system non-linearity, without the computational burden of high-frequency details [2, 12].

c) *Small-signal oriented modeling.* Closed-loop control design, small-signal stability analysis, and module interaction analysis are usually performed by using the powerful simulation tools for frequency-domain analysis [5, 8-13, 18]. Most simulation software has the ability to automatically linearize systems around an operating point and provide various frequency-domain analyses, if the system is:

- continuous in time and state-space, and
- if a constant (not time varying) steady-state solution exists [57].

The average models are continuous, but for AC systems the steady-state solutions are sinusoidal and hence linearized models do not exist. Therefore, it is necessary to develop models in rotating (dq or dq0) coordinates (see Appendix A) for the three-phase AC modules (all blocks from a block diagram from Figure 1, except the input DC source and DC filter). Additionally, the d-q models provide better insight into the dynamics of AC machines and are more convenient for a digital (d-q) controller design [18, 28, 40, 57].

A system model is obtained by connecting the module models together. Modules modeled at the same level can be directly connected due to their terminal compatibility. Modules modeled at detailed and average levels in the same coordinate system can also be directly connected to each other because their terminals are compatible, i.e. they represent either electric or control signal connections. However, to connect modules designed in different coordinate systems (d-q modules and modules in stationary coordinates, either detailed or average), some interface modules must be used. These modules, in our case, provide conversions between rotating and stationary coordinates and between control and electrical variables.

2.2. Module Model Library

The models described below were developed for simulations of the PMSM drive system in Figure 1. Using the modeling approach and conventions described in the previous chapter, the module model library has been developed, so that the models can be used for simulations of other power electronics systems. For the purpose of this work, the modules are modeled at three basic levels, i.e. detailed, three-phase average and dq average models of the system modules are developed. All model parameters are defined to be the user inputs.

2.2.1 Three-Phase Voltage Source Inverter (VSI) Module

A three-phase VSI inverter module was modeled at all three levels. Figure 2.a shows a detailed model, which contains ideal switches and diodes. The module could be further modified by implementing gate drive circuit models, providing switching signals for detailed power-switch models [14] and protection circuit models, but this would not contribute to the main idea of this paper. Control inputs (s_a, s_b, s_c) are switching functions of time $\{0, 1\}$. An average VSI model in stationary coordinates [11] is shown in Figure 2.b, where the control inputs (d_a, d_b, d_c) are average phase duty cycles. A d-q model [11, 13] is shown in Figure 2.c. Basically, VSI in this application works as a buck converter, so that its average model can be derived from the well-known three-phase buck inverter expression [13]:

$$\begin{bmatrix} v_a \\ v_b \\ v_c \end{bmatrix} = \begin{bmatrix} d_a \\ d_b \\ d_c \end{bmatrix} m V_{DC} \quad (1),$$

where v_a, v_b and v_c are its per phase output voltages, i.e. phase voltages on the ac side, considering “y” connection of the load, V_{DC} is a DC link voltage and d_a, d_b and d_c are phase duty cycles of the inverter. A phase duty cycle limitation ($1/2$ or $1/\sqrt{3}$), here called modulation coefficient (a different term from the modulation index), m , is due to the nature of the signal modulation (sinusoidal and SVM, respectively) [78]. Some basic principles of these two PWM modulation approaches are described in Appendix A.

Line-to-line voltage and DC link current can be also expressed in terms of the average phase and line-to-line duty cycle dq components:

$$\begin{bmatrix} v_{ab} \\ v_{bc} \\ v_{ca} \end{bmatrix} = \begin{bmatrix} v_a - v_b \\ v_b - v_c \\ v_c - v_a \end{bmatrix}, \quad \begin{bmatrix} d_{ab} \\ d_{bc} \\ d_{ca} \end{bmatrix} = \begin{bmatrix} d_a - d_b \\ d_b - d_c \\ d_c - d_a \end{bmatrix} \quad (2),$$

$$\begin{bmatrix} \bar{v}_{ab} \\ \bar{v}_{bc} \\ \bar{v}_{ca} \end{bmatrix} = \begin{bmatrix} d_{ab} \\ d_{bc} \\ d_{ca} \end{bmatrix} V_{DC}, \quad I_{DC} = \begin{bmatrix} d_a & d_b & d_c \end{bmatrix} \begin{bmatrix} i_a \\ i_b \\ i_c \end{bmatrix} \quad (3).$$

Equations (1-3) define the three-phase average model of the inverter, shown in Figure 2.b.

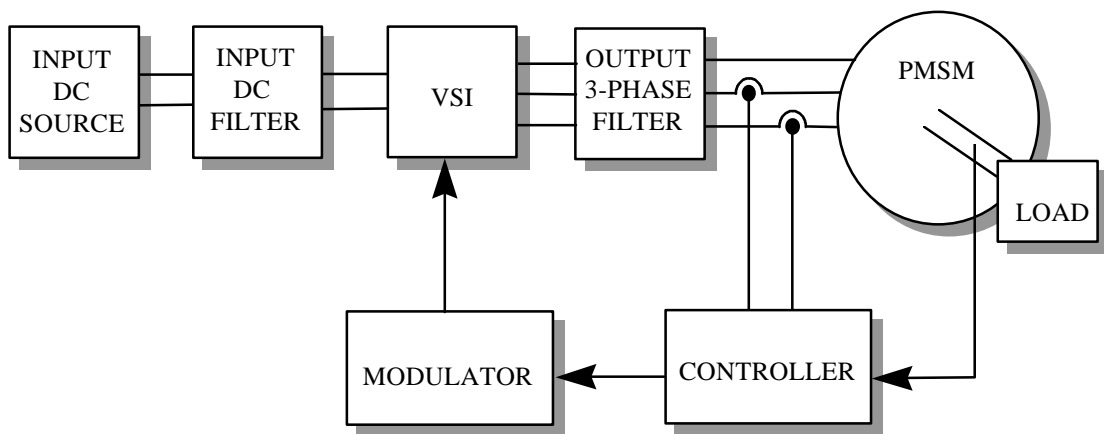
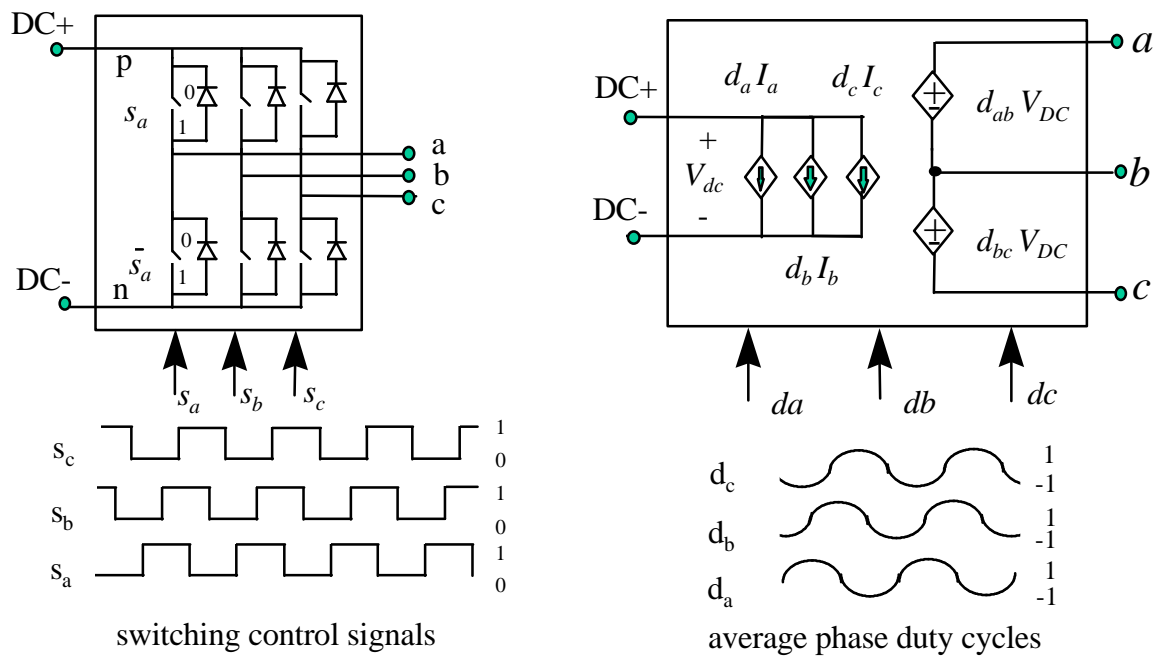
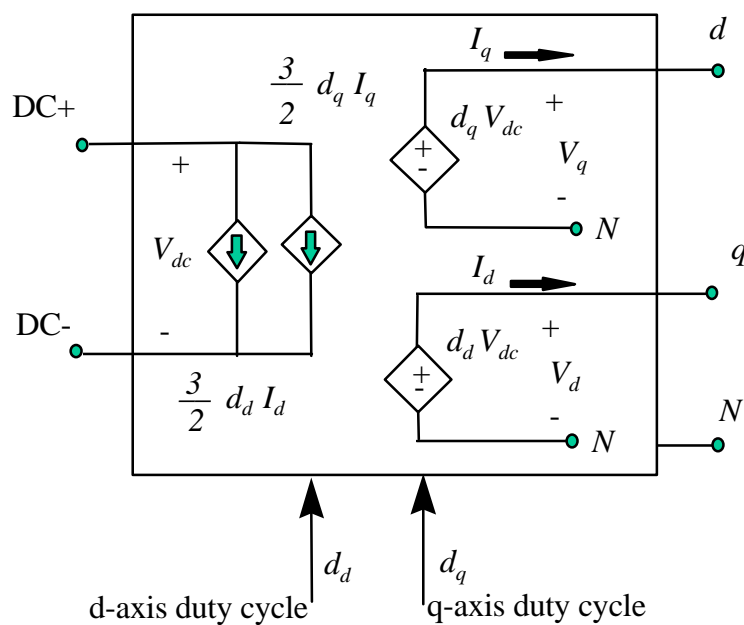

Figure 1. Block diagram of a VSI fed PMSM drive



a) Switching model

b) Average model



c) DQ average model

Figure 2. VSI inverter module models in stationary and rotating coordinates

The d-q components of the phase duty cycle can be defined by applying Park's transformation (see Appendix A) on the phase voltages:

$$\begin{bmatrix} v_d \\ v_q \end{bmatrix} = T \begin{bmatrix} v_a \\ v_b \\ v_c \end{bmatrix} \quad (4)$$

and, in the case of constant DC link voltage, we can define the phase duty cycle d-q components:

$$\begin{bmatrix} d_d \\ d_q \end{bmatrix} = T \begin{bmatrix} d_a \\ d_b \\ d_c \end{bmatrix} \quad (5)$$

Finally, by substituting (1) and (4) into (5), we can get the relationship between dq voltages and dc link voltage, i.e. dq voltage equations of the VSI:

$$\begin{bmatrix} v_d \\ v_q \end{bmatrix} = \begin{bmatrix} d_d \\ d_q \end{bmatrix} mV_{DC} \quad (6)$$

The relationship between d-q current components on the AC side of the VSI and DC link current can be derived from the three phase buck inverter current equations [11]:

$$I_{dc} = \begin{bmatrix} d_a & d_b & d_c \end{bmatrix} \begin{bmatrix} i_a \\ i_b \\ i_c \end{bmatrix} \quad (7)$$

and the inverse of Park's transformation of dq to three phase currents and duty cycles:

$$\begin{bmatrix} i_a \\ i_b \\ i_c \end{bmatrix} = T' \begin{bmatrix} i_d \\ i_q \end{bmatrix} \quad (8)$$

$$\begin{bmatrix} d_a \\ d_b \\ d_c \end{bmatrix} = T' \begin{bmatrix} d_d \\ d_q \end{bmatrix} \quad (9)$$

Substituting (5) and (8) into (7), after some matrix calculations, we can get the necessary current relationship:

$$I_{dc} = \frac{3}{2} \begin{bmatrix} i_d \\ i_q \end{bmatrix} \quad (10).$$

In this way the complete three-phase average VSI model is transferred from three-phase to d-q coordinate space, i.e. the dq model is defined. Both average models are internally designed in control signal space, where terminal compatibility of the three-phase model with the outer system circuit is provided through the Analogy's DesignStar electrical-to-control and control-to-electrical transformation blocks [17]. Finally, the relationship between dc link power and three-phase power in three phase and dq coordinates can be expressed as:

$$P_{dc} = V_{dc} I_{dc} = \frac{\sqrt{3}}{2} V_{l \max} I_{l \max} \cos \mathbf{j} = \frac{3}{2} V_{ph \max} I_{ph \max} \cos \mathbf{j} = \frac{3}{2} (V_d I_d + V_q I_q) \quad (11)$$

where a, b, c represent phases a, b and c, l line-to-line and ph phase-to-neutral variables; \mathbf{j} is a voltage to current phase shift and \mathbf{w} their angular frequency. It can be used for the design of the interface blocks between the power losses modules modeled in the two above mentioned coordinate systems, as well as the evaluation of the system input impedance.

2.2.2. Permanent Magnet Synchronous Motor (PMSM) Module

Transformed to dq space, the PM synchronous motor model is determined by a standard dq state-space mathematical model (common “y” connection of stator windings and three-phase balanced system are assumed) [61, 65]:

$$\begin{aligned} v_d &= R i_d + L_d \frac{di_d}{dt} - p L_q \mathbf{w} i_q \\ v_q &= R i_q + L_q \frac{di_q}{dt} + p L_d \mathbf{w} i_d + k_t \mathbf{w} \\ T_m &= \frac{3}{2} (k_t i_q + p(L_d - L_q) i_q i_d); \quad T_{load} = T_{load0} + \sum_i k_{load_i} (\mathbf{w} - \Omega_i) \\ T_m - T_{load} - T_{fr} &= J \frac{d\mathbf{w}}{dt} \\ v_s &= \sqrt{v_d^2 + v_q^2} = V_{ph}; \quad i_s = \sqrt{i_d^2 + i_q^2} = I_{ph} \\ v_{s \max} &= \frac{1}{\sqrt{3}} V_{dc} \dots \text{with SVM}, \quad v_{s \max} = \frac{1}{2} V_{dc} \dots \text{with sinusoidal PWM} \end{aligned} \quad (12)$$

Parameters and variables are given in Table 1.

Table 1. Motor parameters and variables

v_q, i_q :	q-axis stator voltage and current	v_d, i_d :	d-axis stator voltage and current
R :	stator phase resistance	L :	stator phase self inductance
L_q :	stator inductance in q axis	L_d :	stator inductance in d axis
k_t :	torque constant.	p :	number of pairs of poles
w :	instantaneous rotational speed, $\omega > \Omega$	W :	rotational speed at a load-torque slope break point
T_m :	motor electromechanical torque	T_{load} :	load torque
T_{fr} :	friction	J :	moment of inertia

The d-q axis orientation is presented as the example of a two-pole machine in Figure 3. The motor dq0 module models are shown in Figure 4. The models are designed for electrical (Figure 4.a) or control signals (Figure 4.b). The advantages of the electrical signal model are that it offers the possibility for more detailed modeling because it contains very detailed saber models of passive circuit elements (R, L, C), and it doesn't require electrical/control signal transformations on its terminals. On the other hand, the control signal model is, in terms of simulation, faster because of its simple mathematical nature. All current and voltage vector magnitudes in the control signal model are related to the maximum phase values of currents and voltages in a three-phase system, respectively.

The model mechanical output interface is compatible with Saber/DesignStar connections for modeling of rotating mechanical systems [17]. A mechanical load is modeled with a load-torque function of speed using an empirically obtained look-up table. However, using the Saber library of mechanical components, models of complex mechanical systems can be readily implemented.

Detailed (switching) and average models of PMSM in stationary coordinates already exist in the original Saber libraries [16, 17], and their design was beyond the scope of this work.

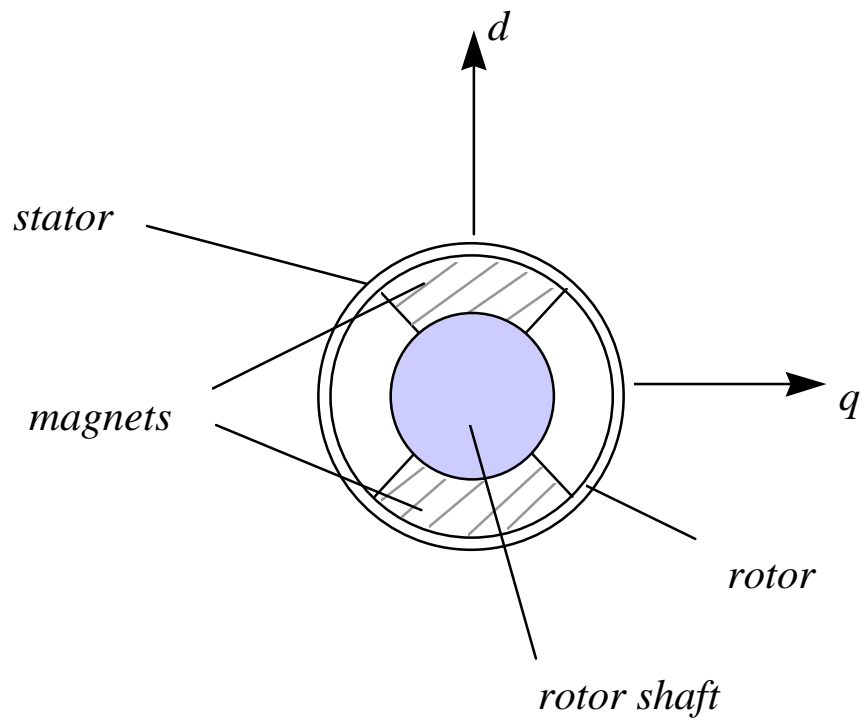
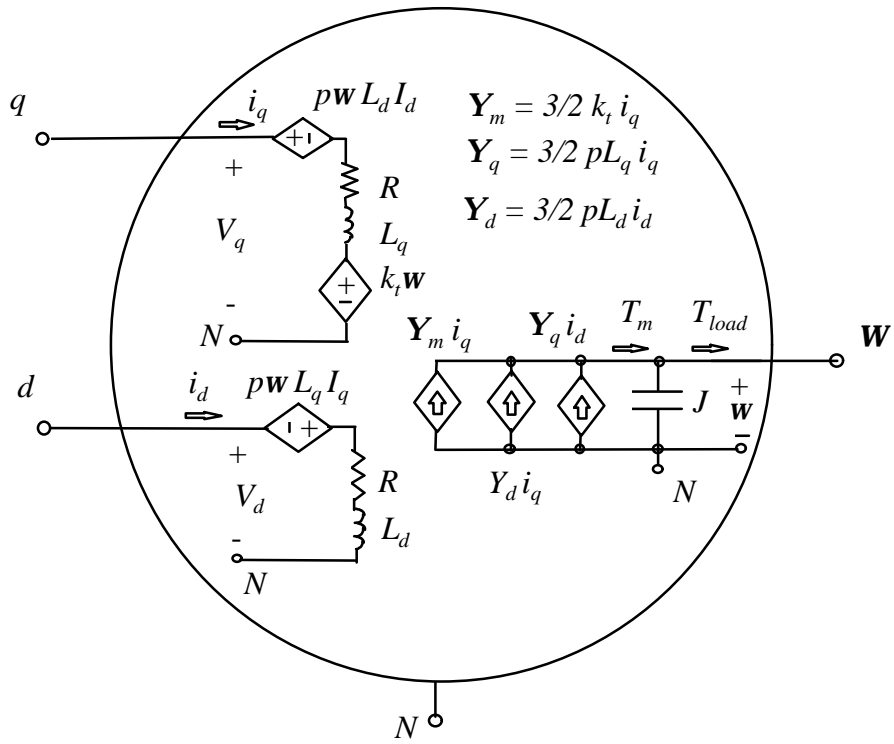
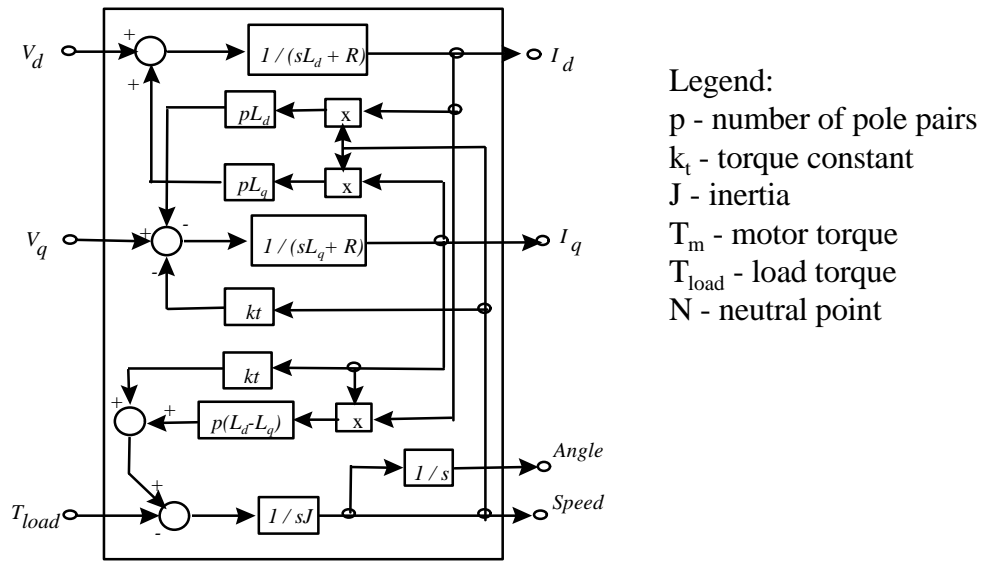

Figure 3. DQ axis orientation in a two pole PMSM



a) Electrical signal model



b) Control signal model

Figure 4. PMSM module dq0 models

2.2.3 Filter Modules

An input DC filter, Figure 1, can be modeled with models of circuit elements that appear in a real filter design [47]. The level of model complexity depends on how detailed the analysis should be. A DC link source from Figure 1 is modeled as a simple DC voltage source although any model of an electric circuit can be applied. A three-phase (EMI) filter model is easy to realize in stationary three-phase coordinates, using the mentioned passive circuit element models and following the real filter design [23], Figure 5.a. The other possibility is to design a d-q filter model, Figure 5.b, which could be preferable for the control design. However, due to the complexity of filter modeling in rotating d-q coordinates (Figure 5.b), the usefulness of d-q models of multiple stage filters is questionable. A possible reason for such a modeling could be to analyze the filter-motor impedance interaction [23, 35, 47], or the coupling effect to the system d-q transfer functions, due to the filter energy storage elements (inductors and capacitors). Otherwise, the mixed level modeling with the filter model in stationary three-phase coordinates, connected to the rest of the system either directly or through the interface blocks, is strongly recommended. It strongly underlines the advantages of the mixed level modeling approach over the classical, three-system-level modeling.

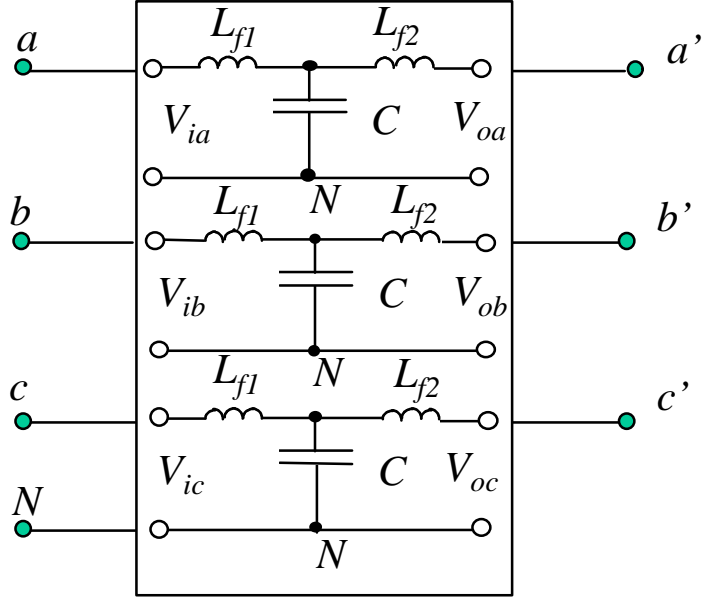

a) Three-phase model

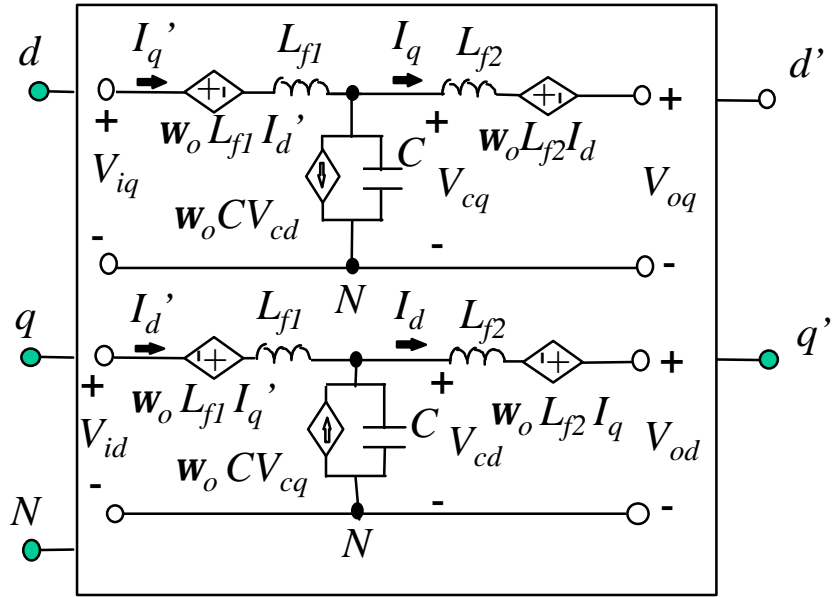

b) DQ model

Figure 5. Three-phase filter module models in a) stationary and b) rotating coordinates

2.2.4 Cascade Controller Module

A module model of a modern, two stage field-oriented digital controller with a decoupling circuit [13, 20, 38, 50], and variable limit PI regulators (VLPI) in both inner, d- and q- current control loops, and the outer, speed loop, is shown in Figure 6. The VLPI regulator is a version of the PI regulator with the integrator anti-windup [79, 80]. Any other controller can be designed either in dq or stationary three-phase coordinates and implemented in the system diagram through interface blocks. The outputs of the controller are VSI switching duty cycles in dq coordinates. Closer analysis of the controller design is a topic of Chapter 3.

2.2.5 PWM Modulator Module

The modulator module outputs have to be compatible with the VSI control inputs, so that three different models were developed referring to the VSI models in Figure 2. The switching model (Figure 7.a) was developed in “Mast,” the Saber programming language [16]. It allows an easy implementation of any modulating algorithm. The inputs of the modulator model are two-phase signals in stationary α - β coordinates, equivalent to average-duty-cycle components, d_α and d_β . Hence, for the connection with the controller (see Section 2.2.4.), it is necessary to have an interface block which transforms control signals from d-q (or dq0) to α - β (or $\alpha\beta\gamma$) coordinate space. Since only the balanced system is considered in our example, “0” and “ γ ” components are neglected. The average modulator model (Figure 7.b) simply transforms two-phase inputs (α , β) into three-phase outputs (a, b, c), using a standard two-phase-to-three-phase Park’s transformation matrix [11], (see Appendix A).

The only constraint is that line-to-line duty cycle signal cannot exceed the unity value. For that purpose, the phase duty cycle control signals are scaled adequately, regarding maximum phase voltages (1 and 12). The models also include sampling and switching time delay approximated transfer functions in s-domain, [11, 13]. Due to its DC average signal nature, the d-q PWM model (Figure 7.c) contains only Pade’s second-order approximation of the sampling time delay [13] and a modulation coefficient from (12).

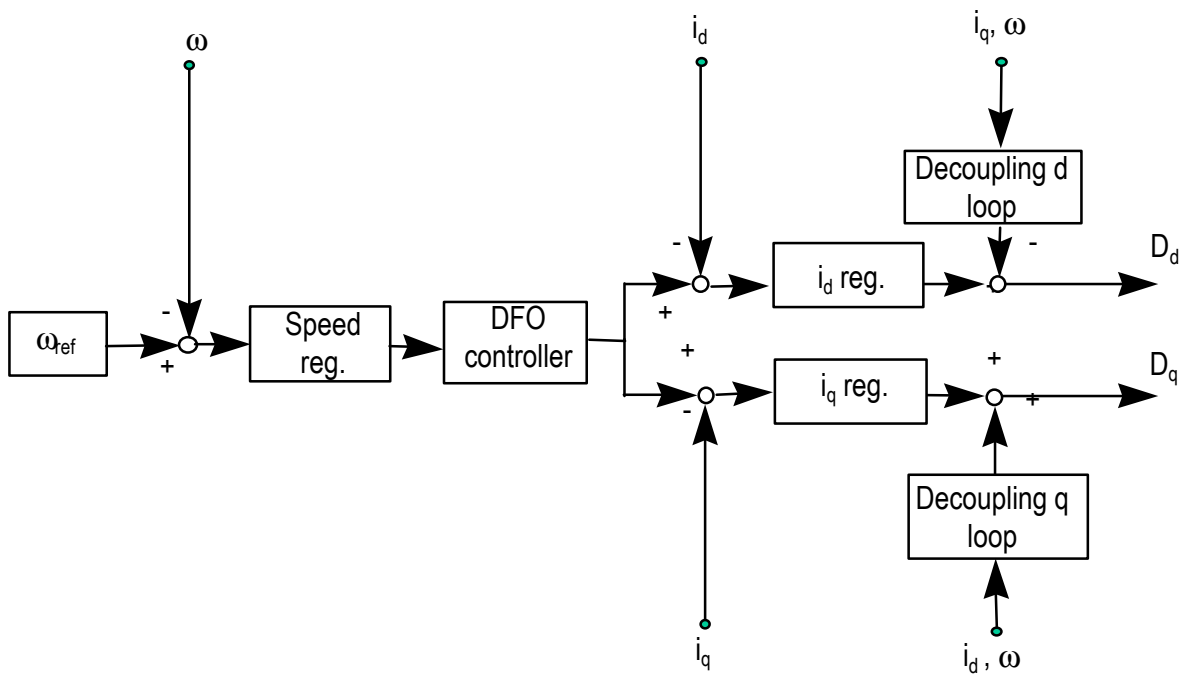
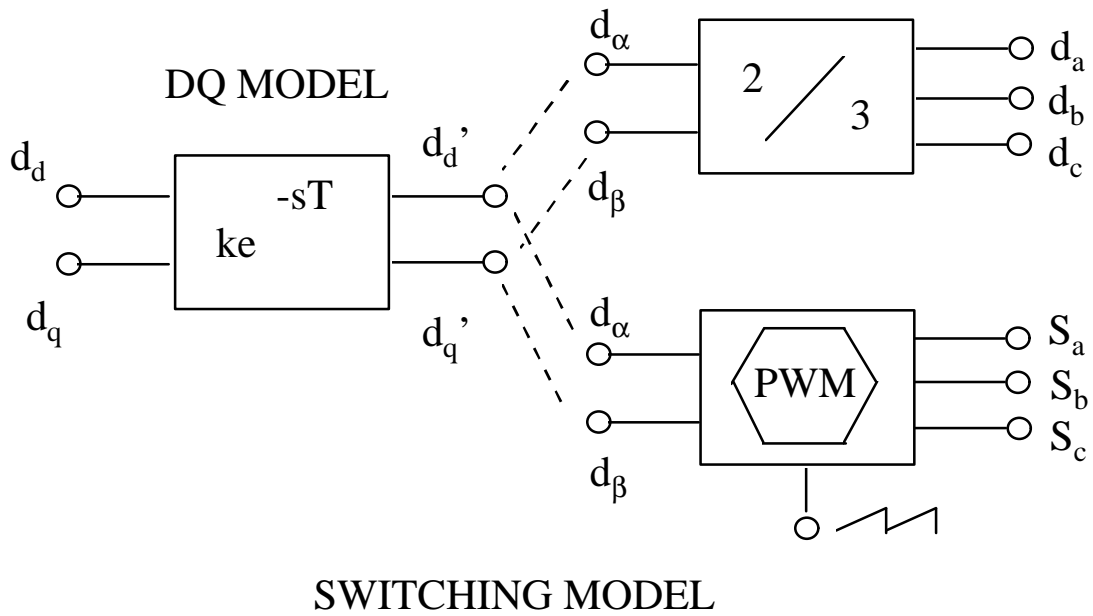

Figure 6. Two-stage cascade controller module model

THREE-PHASE AVERAGE MODEL



Legend:

ke^{-st} - computation and modulation delay

k - modulation coefficient

t - sampling period

Figure 7. Modulator module models in stationary and rotating coordinates

2.2.6 Interface Modules

The interface modules (Figure 8) are the crucial parts for the mixed level system modeling. There are two types developed for this occasion. The first one (Figure 8.a) contains Park's and inverse Park's transformation blocks of phase voltages and currents (Appendix A), [11, 57]. Since it serves to connect by two variables (voltage and current) determined electrical signals with only one variable-defined control signal, it is necessary to have a double signal transformation - from the electrical three-phase system to the control signal system which provides the inputs to the dq models (in this example phase voltages to dq voltages), and vice-versa, i.e. the outputs of a d-q model must be transformed back to the three-phase electrical system (in this example d-q currents to phase currents) to complete the electrical system requirements. The above mentioned Saber models of electrical-to-control and control-to-electrical interface, current dependent voltage sources, and voltage dependent current sources [17] are used for these purposes. The other type of the interface block, mentioned in Section 2.2.5, contains the transformation matrix from rotational d-q, to stationary α - β coordinates. Although in this application interface blocks are used for a balanced three-phase system, the complete $dq0$ -to- $\alpha\beta\gamma$ blocks for unbalanced systems are also developed.

Besides those noted above, various interface blocks can be developed and implemented to link modules developed in different coordinate frames [55], by transforming their determining input and output variables from one coordinate system to another.

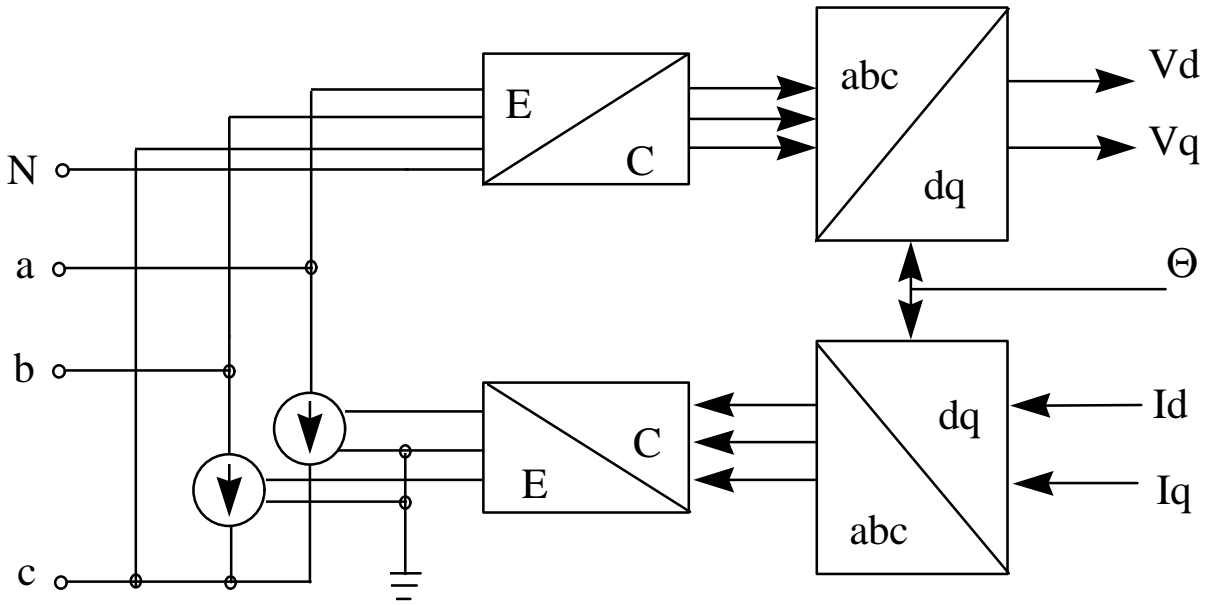

a)

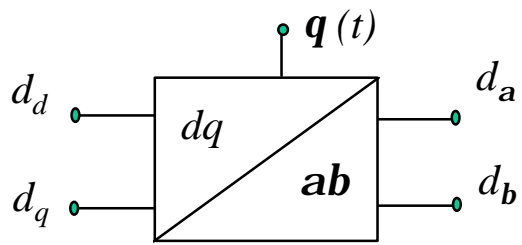

b)

Figure 8. Interface blocks for a) three-phase/d-q module connection and b) transformation from d-q to **a-b** coordinates

2.3 Modeling Issues

Several obstacles appeared during the design the of presented models. The three most characteristic problems are related to the ground and neutral points, as well as the electrical-control signal transformations, Figure 9:

1) A ground point problem appears when several independent models (each with its own ground point) are intended to be connected together. Then, another ground point placed arbitrarily in the circuit can lead to either a simulation failure, or in inaccurate simulation results. Here the presented models are not internally grounded (except some control signals in which grounding doesn't have any influence on the main signal flow), so that they can be connected together to form a system where only a user defined ground (reference) points exist, as will be the case with any real electric network design.

2) A neutral point reference problem exists in modeling systems with isolated neutral points. The usual solutions, connecting the neutral and ground points through a large resistance or some other passive element, lead to inaccurate neutral-point related simulation results (e.g. phase voltages). In order to create the output voltage signal of the VSI three-phase average model, the line-to-line voltage generators are used between phases a and b , and phases b and c . The problem appears when the reference point for the phases must be defined. Instead of connecting the neutral point to the ground point, it is connected to the middle point of the DC link. Since the resistors used between the DC link and its middle point are large, the current through the neutral point of a balanced system is small and split equally between the resistors, so that their voltage drops cancel each other. Hence, the phase voltage error caused by the voltage drop over a “dummy” big resistor (or element) connecting the neutral point and the ground is avoided. Also, it assures that different placements of the ground point in the system will result in different phase voltage offsets, which is what actually happens in reality. Some software packages provide an isolation transformer model which provides even better results, especially in a very steep signal analysis, as is the case of the analysis of switching transients of detailed, lossy models of power switching devices.

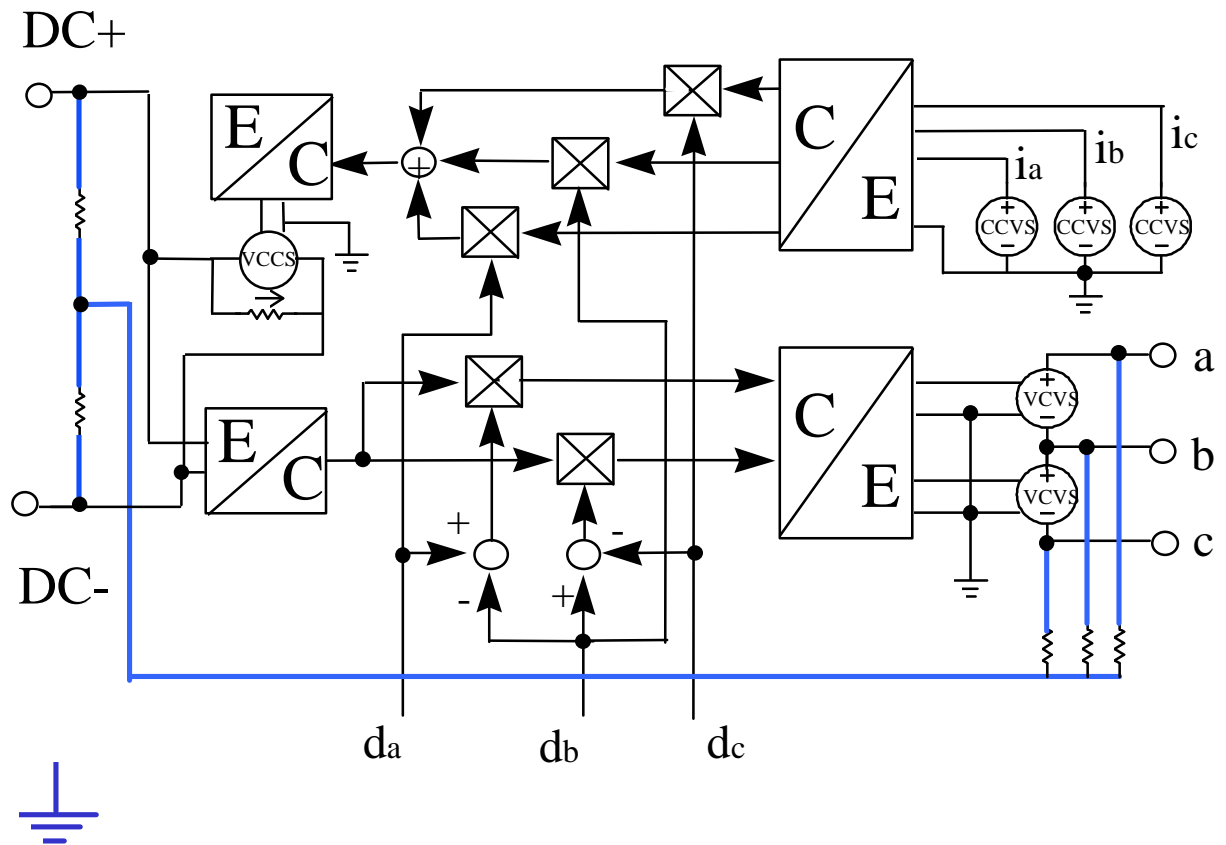

Figure 9. VSI three-phase average modeling - signal transformations

3) Connections in multilevel systems require understanding the principles of the signal flow at each level. For example, in the above analyzed VSI three-phase average model, Figure 9, two different kinds of signals are combined. The electrical signal is used for the connection of the model to the electrical part of the system model, Figure 1. As is mentioned in Section 2.2, the signal flow through the lines in the electrical part contains information about two variables: the line potential and the line current. On the other side, the signal flow through the lines in the control part, used for modeling of the VSI average behavior, contains only the information about one unit-less control variable. Hence, in order to design such a model to be compatible with both the electrical and control signal environment, both the current and voltage signals must be generated on its electrical inputs and outputs. The same principle should be applied in any mixed signal module, as is the case with earlier mentioned average VSI and interface block module models (Figures 2.b and 8.a).

2.4 Model Verification

The system models are verified through the comparison of the simulation results obtained with the dq average model and the measurements accomplished with the open loop drive system. The hardware testing is performed by using the following equipment:

1) impedance analyzer, used for estimation of the power stage/motor parameters and for calculating and displaying transfer functions according to the ratio between signals coming to its output and input (reference) ports. It also provides a test signal, from which the current reference signal is derived;

2) anti-aliasing (measurement) filter, a low pass filter which cuts high harmonics of the test signal (above a half of the inverter switching frequency) in order to avoid the interaction between a tested unit and the impedance analyzer;

3) analog-to-digital (A/D) converter for A/D transformation of the reference test signal in order to obtain the perturbation of d or q component of the reference current;

4) digital to analog (D/A) converter (the same as 3, if it is bi-directional), which provides analog output signals of the d and q components of the motor current;

5) digital control board with PWM modulator;

- 6) power stage board, which is the testing object with load and measurement equipment;
- 7) DC and AC power supplies; and
- 8) harmonic spectrum analyzer, if the harmonic spectrum analysis is desired.

The measurement procedure can be divided in four parts:

- 1) measurement of the power stage/motor parameters;
- 2) measurement and analysis of the open/closed control loops in frequency domain;
- 3) step response analysis; and
- 4) harmonic spectrum analysis.

Part 1. A measurement scheme for a three phase motor/load parameter estimation is represented in Figure 10. Since the impedance analyzer provides a tool for the separation of the real and imaginary parts of the measured impedance, from the nature of the tested circuit (for example RL circuit), it is possible to evaluate the tested impedance parameters. For the measurements of the d-axis and q-axis components of a synchronous motor stator inductance, it is necessary to orient the motor by replacing the impedance analyzer with a dc voltage source. Once the rotor is stabilized, i.e. the rotor and stator fields are aligned, the dc voltage source can be replaced by the impedance analyzer and the measurement of d-axis inductance can be executed.

In order to measure the stator inductance in the q-axis, the number of the motor pole pairs must be known. This can be tested by running the motor at a constant speed and measuring the speed and the stator voltage frequency (both in the same units). Their ratio gives the number of pole pairs. This, subsequently, gives the ratio between mechanical and electrical degrees, i.e. the information about the angle for which the rotor shaft must be turned to produce a given phase shift between the rotor and stator fields. Now, the rotor shaft should be turned mechanically to produce a 90° el. phase shift between the stator and rotor fluxes in the air gap and the measurement of the q-axis inductance can be accomplished.

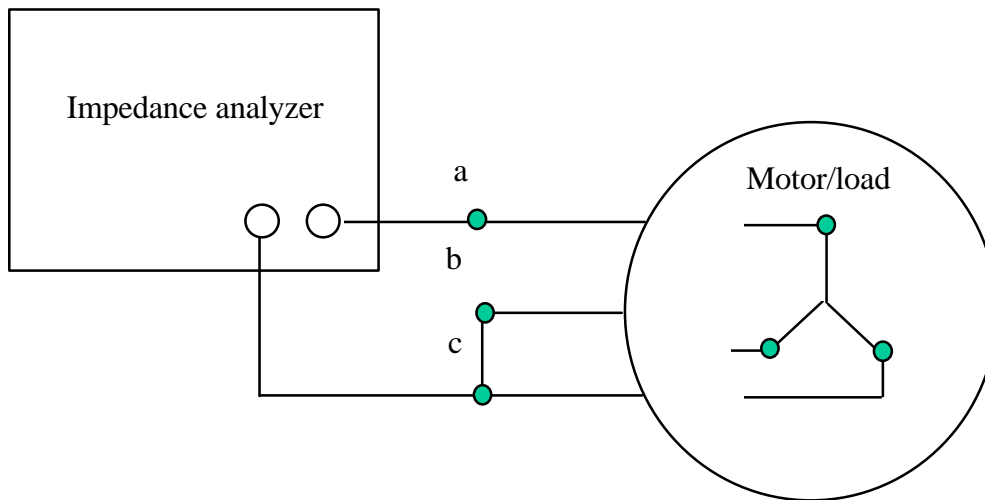

$$Z_{ph} = \frac{2}{3} Z_{measured}$$

Figure 10. Measurement setup for the system impedance evaluation

The measurement of the back emf (or torque) constant can be done by rotating the rotor shaft at a certain speed and measuring the speed (or the stator frequency) and the voltage on the stator open terminals, i.e. the line voltage, while the third phase is kept open. All measurements should be repeated for each phase corresponding to the setup at several operating points (different speeds) and the average result should be taken as correct.

Part 2. Measurement scheme for frequency domain analysis is presented in Figure 11. The procedure consists of three steps:

- 1) Connect all elements of the measurement circuit and check if everything is ready for the experiment;
- 2) Leave (d-q) current feedback loops open and measure loop-gain transfer functions;
- 3) Close the current loops and repeat the measurement to obtain closed loop transfer functions

Part 3. Step response measurement setup is the same as the one represented in Figure 10, except that the impedance analyzer is replaced with the oscilloscope and the test signal is provided from an adjustable voltage source. A small step signal is induced in the reference signal, what can be realized digitally. The oscilloscope should have the ability to “freeze” the picture fast. The measurement procedure is to apply a step reference signal at critical operating points and to scan the tested unit response on the oscilloscope.

Part 4. The spectrum analysis is beyond the focus of this work. The measurement procedure consists of connecting the oscilloscope with the internal harmonic analyzer to the desired signal and scanning the signal harmonic spectrum.

The measured and simulated open-loop current control-to-output transfer functions in the q-axis and sampling delay transfer functions are shown in Figure 12. The tested drive system parameters are:

Motor: $R=0.2 \Omega$, $L_d=1.9 \text{ mH}$, $L_q=5.1 \text{ mH}$, $k_t=0.32 \text{ V}/(\text{rad}/\text{s})$, $J=0.06 \text{ kgm}^2$, $T_{\text{load}}=2.16\text{Nm}$, $B_l=0.05\text{Nm}/\text{rads}^{-1}$;

VSI: $V_{\text{dc}}=60 \text{ V}$, $f_s=20 \text{ kHz}$, $T_{\text{sampl.}}=50 \mu\text{s}$, $d_d^*=0$, $d_q^*=0.275$. Operating point: $\omega=53 \text{ rad}/\text{s}$.

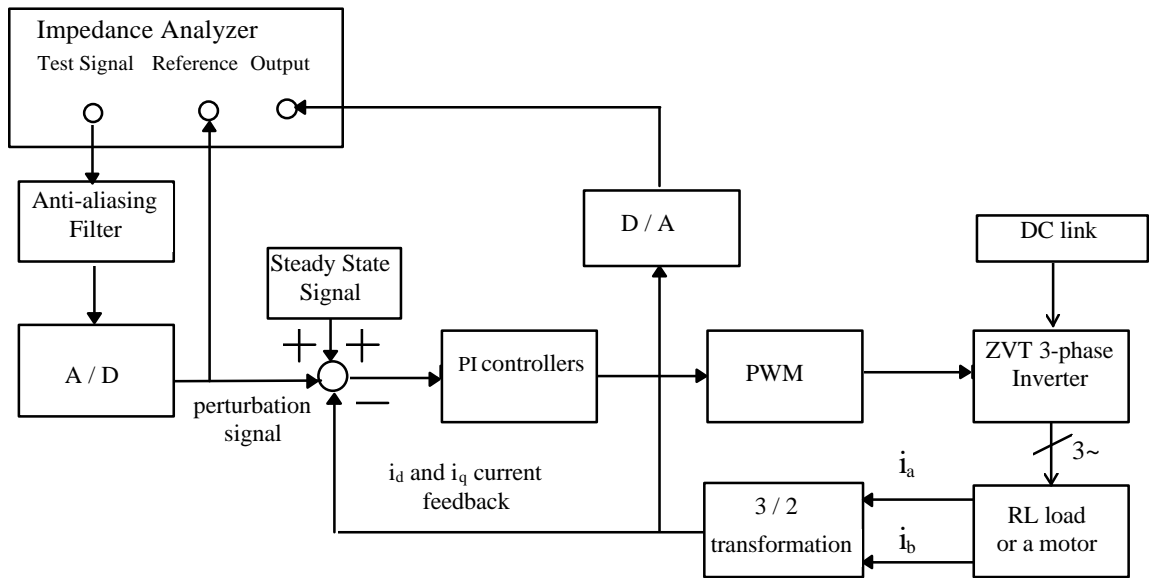
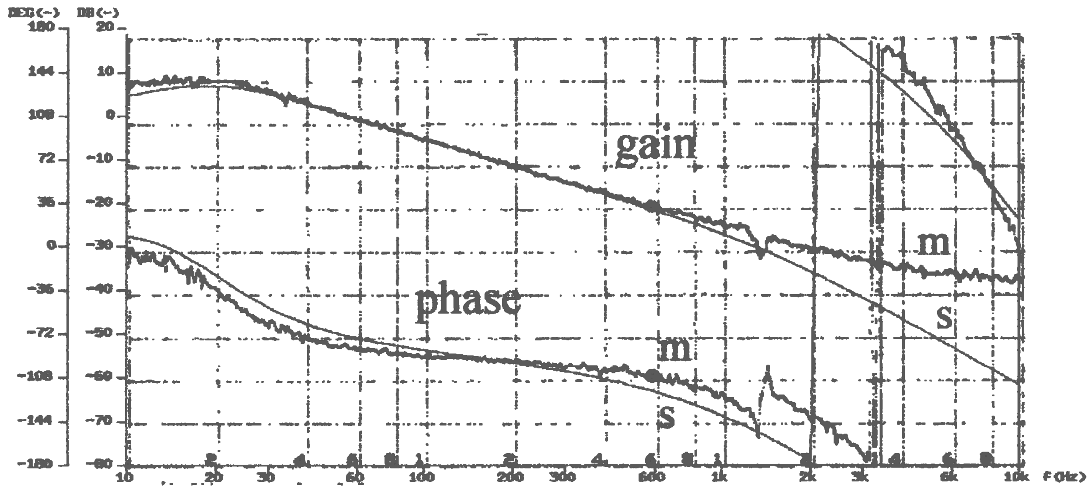
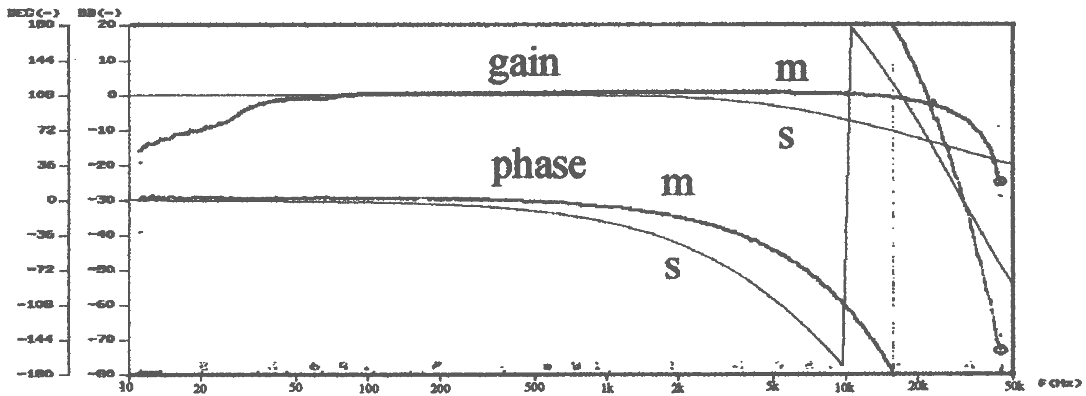

Figure 11. Measurement scheme for current loop transfer functions



Legend:
 m - measurement
 s - simulation

a) I_q current control-to-output transfer function



Legend:
 m - measurement
 s - simulation

b) Sampling delay transfer function

Figure 12. Model comparison with measurements: a) PMSM drive current control-to-output and b) Sampling delay transfer functions

The sampling delay (including VSI switching delay) transfer function is measured with a passive RL load, under switching frequency $f_s=67.5$ kHz. It is shown (Figure 12) that the simulation results of the open-loop transfer functions of the VSI-fed PMSM drive (Figure 12.a) and PWM modulator (Figure 12.b) models match the measurement results at certain high levels. The deviations in the PWM modulator Bode plots are due to the rough approximation of the sampling delay, which will be discussed in Section 3.2.1. The simulation results of several operating scenarios of the PMSM drive system with variously complex models and their comparisons are presented and discussed in Chapter 4.

These results verify the system simulation model and recommend it to be used as a platform for the control design. Hence, the goal of providing a simulation tool for the control design and analysis of permanent magnet synchronous motor drive systems is accomplished.