

Using Thermography to Evaluate the Effects of Arm Flexion and Loading on the Anterior Deltoid during a Simulated Overhead Task

Ian C. Bertmaring

Thesis submitted to the Faculty of the Virginia Polytechnic Institute and State University in
partial fulfillment of the requirements for the degree of

Master of Science

in

Industrial and Systems Engineering

Kari L. Babski-Reeves, PhD, Chair

Maury A. Nussbaum, PhD

Elaine P. Scott, PhD

4-13-2006

Blacksburg, Virginia

Keywords: thermal imaging, isometric contraction, thermography, exertion, moment

Copyright 2006, Ian C. Bertmaring

Using Thermography to Evaluate the Effects of Arm Flexion and Loading on the Anterior Deltoid during a Simulated Overhead Task

Ian C. Bertmaring

ABSTRACT

Shoulder injuries are a focus of work related musculoskeletal disorder (WMSD) research due to rising healthcare costs, an aging workforce, and long recovery times. Substantial research has been performed in the area of shoulder WMSDs and a number of risk factors have been implicated in their development; including static loads, repetition, and deviated posture. However, knowledge of underlying pathophysiological mechanisms is limited. Thermography provides a non-invasive technique that may offer clues to unknown physiological markers associated with injury development during job task performance. The objective of this study was to quantify anterior deltoid surface temperature changes as function of changing task demands. Skin surface temperature changes of the anterior deltoid, modified Borg CR-10 ratings, and endurance time during overhead static exertions until exhaustion for two work loads (15 and 30% MVC) and shoulder angles (90° and 115°) were quantified. Ten participants (5 males and 5 females) participated in the study and were free of confounding conditions (such as chronic or acute shoulder injury) and were required to meet body fat percentile requirements. Thermography showed that the higher shoulder angle had a reduced blood flow while there were no differences in temperature for exertion. Modified Borg ratings were not found to be well correlated with temperature values. The findings suggest that workers performing overhead work should minimize their deviated posture when available to prevent a high risk of developing a shoulder WMSD.

ACKNOWLEDGEMENTS

I would like to express my deepest gratitude to my advisor, Kari L. Babski-Reeves, PhD, and other committee members, Maury A. Nussbaum, PhD and Elaine P. Scott, PhD, for their guidance and knowledge. I would also like to thank the National Institute of Occupational Safety and Health and the Grado Department of Industrial and Systems Engineering for providing funding for my graduate education and research.

Appreciation is given to the statistical centers of Virginia Tech and The University of North Carolina for their direction and assistance with statistics, in particular Susanne Aref (VT), Christopher Wiesen (UNC), and Xin Zhong (VT).

Lastly, I would like to thank my friends, family, experiment participants, employer, coworkers, and fellow students for continued support, encouragement, time, and patience.

TABLE OF CONTENTS

INTRODUCTION	1
1.1 Background	1
1.2 Problem Statement	3
1.3 Objectives of the Study	4
1.4 Scope and Limitations of the Study	4
LITERATURE REVIEW	5
2.1 Risk factors and potential sources of overhead WMSDs	5
2.1.1 Deviated Postures.....	5
2.1.2 Muscle Load.....	7
2.1.3 Elbow Postures.....	8
2.1.4 Hand Activity.....	8
2.2 Thermography	9
2.2.1 Myalgic muscles and blood flow.....	9
2.2.2 Blood Flow Theories.....	10
2.2.3 Current Thermography Research and Applications.....	11
2.2.4 Limitations in Using Thermography.....	11
2.3 Summary	12
METHODOLOGY	13
3.1 Experimental Design	13
3.2 Independent Variables	13
3.2.1 Shoulder Angle.....	13
3.2.2 Exertion Level.....	17
3.2.2.1 Maximum Voluntary Exertions.....	18
3.3 Dependant Variables	19
3.3.1 Thermography.....	19
3.3.2 Endurance Time.....	21
3.3.3 Discomfort Rating.....	21
3.4 Testing Environment	22
3.5 Task	22
3.6 Participants	23
3.6.1 Screening Procedure.....	23
3.6.2 Familiarization Session.....	26
3.7 Procedure	26
3.8 Statistical Analysis	27
3.8.1 Normality Tests.....	27
3.8.2 ANOVA, ANCOVA, and Correlations.....	27
RESULTS	28
4.1 MVE	28
4.2 Experimental Duration	29
4.3 Temperature Data	29
4.4 Modified Borg CR-10 Ratings	35
4.5 Correlations	36
4.6 Visual Analogue Discomfort Scale (VADS)	36
DISCUSSION AND CONCLUSIONS	38

5.1 Discussion	38
5.2 Conclusions	40
5.2.1 Limitations	40
5.3 Future Directions	42
5.4 Summary	44
REFERENCES	45
APPENDIX A	52
Form 1: Participant Data	53
Form 2: Demographics and Musculoskeletal Data	54
Form 3: Anthropometric and Workstation Data	55
Form 4: Experiment Data Sheet	56
Form 5: Apparatus Heights and Visual Numerical Discomfort Scale	57
Form 6: Visual Analogue Discomfort Scale	58
Form 7: Subjective Rating of Perceived Discomfort (RPD) – Borg CR-10	59
APPENDIX B	61
VITA	72

LIST OF FIGURES

Figure I.1. Number of non-fatal shoulder injury cases producing lost workdays (data from BLS, 2006a)	1
Figure I.2. Percentage of total shoulder injuries or illnesses and the percentage caused by bodily reaction and exertion compared to total trunk injury or illnesses (data from BLS, 2006a)	2
Figure I.3. Lost workday case incidence rates, injuries and illnesses, 1976-2004 (data from BLS, 2001; BLS, 2006b; Ruser, 1999).....	2
Figure III.1. Testing apparatus: (A) Left side image, (B) Frontal image, (C) Right side image, (D) Overhead image	14
Figure III.2. Shoulder angle free body diagrams	17
Figure III.3. Temperature comparison between the two anterior deltoid regions	20
Figure III.4. Detailed area picture of the areas on the right arm in relation to the penny.....	21
Figure IV.1. Area 3 dominant arm temperature data for each experimental condition.	30
Figure IV.2. Area 3 non-dominant arm temperature data for each experimental condition.....	30
Figure IV.3. Condition S1/E2 dominant arm temperature data.....	31
Figure IV.4. Mean temperature slope for arm by shoulder angle (* Measured in thousandths of a °C).....	33
Figure IV.5. Mean temperature slopes for muscle location (distance) by arm.....	34
(* Measured in thousandths of a °C)	34
Figure IV.6. Mean temperature slopes for arm by gender interactions (* Measured in thousandths of a °C)	34
Figure IV.7. Mean modified Borg slopes for shoulder angles.....	36
Figure IV.8. Visual Analogue Discomfort Scale mean and maximum reported values for each body part.	37

LIST OF TABLES

Table III.1. The presentation order; balanced with repeated Latin squares. S = Shoulder Angle, E = Exertion Level	13
Table III.2. Link Length Percentiles, measurements in meters (m) ¹ (Webb Associates, 1978) ² (Kroemer, 1994)	15
Table III.3. Distances to Center of Mass (COM), measured in meters (m) (Dempster, 1955) ..	15
Table III.4. Descriptive statistic means and standard deviations of the participants	23
Table III.5. Body fat percentiles for males and females of 20-29 years of age. (American College of Sports Medicine, 2000)	24
Table IV.1. Descriptive statistic means and standard deviations for dependant variables	28
Table IV.2. Participant shoulder angle MVE means and standard deviations for each arm and gender	29
Table IV.3. Temperature slope ANCOVA for each shoulder angle, exertion level, arm, distance, position, time, and their interactions of interest	32
Table IV.4. Post-hoc arm by shoulder angle comparisons for mean temperature slope	32
Table IV.5. Post-hoc arm by distance comparisons for temperature slope	33
Table IV.6. Post-hoc arm by gender comparisons for mean temperature slope	34
Table IV.7. Modified Borg Slope ANOVA for each shoulder angle, exertion level, arm, gender, and their interactions.....	35
Table IV.8. Modified Borg Slope for each experimental condition regardless of arm selection or participant	36
Table A.1. The presentation order; balanced with repeated Latin squares. S = Shoulder Angle E = Exertion Level	60
Table B.1. Participant demographic, fitness level, and past injury data	62
Table B.1. (Continued) Participant demographic, fitness level, and past injury data.....	63
Table B.1. (Continued) Participant demographic, fitness level, and past injury data.....	64
Table B.2. Participant anthropometrics and work distances.....	65
Table B.2. (Continued) Participant anthropometrics and work distances	66
Table B.2. (Continued) Participant anthropometrics and work distances	67
Table B.2. (Continued) Participant anthropometrics and work distances	68
Table B.2. (Continued) Participant anthropometrics and work distances	69
Table B.3. Temperature slope ANOVA for each shoulder, exertion, arm, distance, position, time, and their interactions	70
Table B.4. Correlations for temperature slope.....	71

CHAPTER I

INTRODUCTION

1.1 Background

Over 82,000 new work related musculoskeletal disorders (WMSD) of the shoulder were reported in 2004, second only to WMSDs of the back (BLS, 2006a). Though the total number of shoulder WMSDs is decreasing (Figure I.1), the percentage of shoulder injuries or illnesses, and those caused by bodily reaction and exertion are increasing when compared to total trunk injury or illnesses (Figure I.2). The frequency of some shoulder disorders have been reported to be as high as 40% in selected occupations, such as construction (Holmström et al., 1992; Olson, 1987), and there is evidence that this percentage is increasing (Sommerich et al., 1993). Numerous risk factors have been implicated in shoulder WMSD development; including static loads, repetition, and deviated postures. These factors are hypothesized to contribute to shoulder musculoskeletal disorders (MSDs) by increasing mechanical strain; compressing nerves, muscles, and tendons; and impairing blood flow to the shoulder region and tissues (Hagberg, 1992).

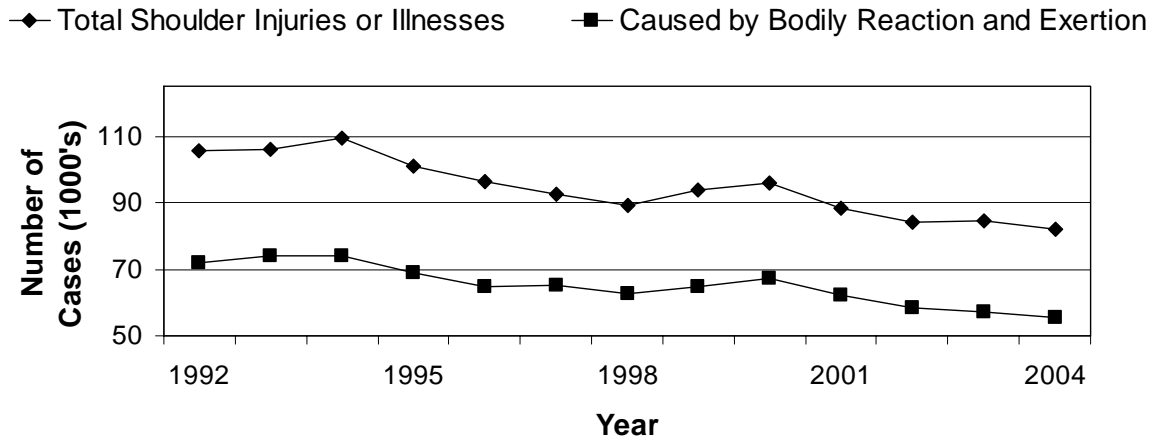

Figure I.1. Number of non-fatal shoulder injury cases producing lost workdays (data from BLS, 2006a)

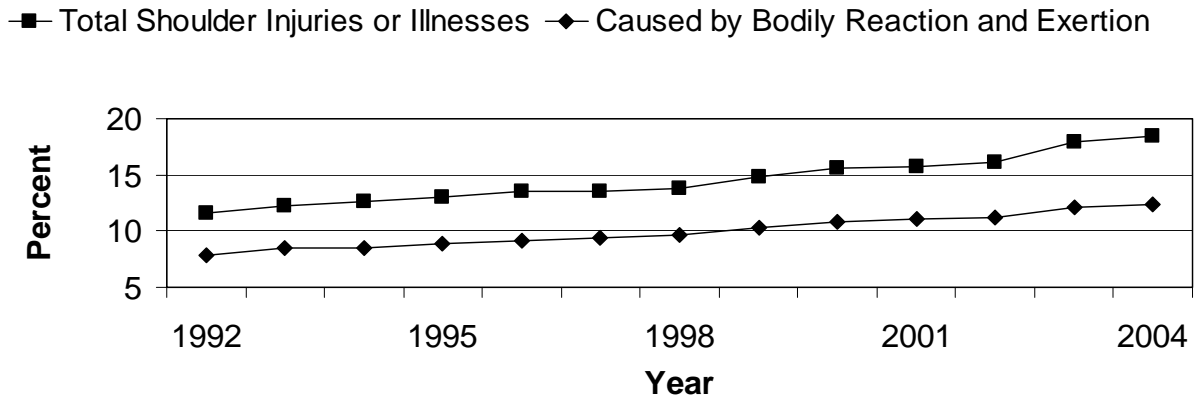

Figure I.2. Percentage of total shoulder injuries or illnesses and the percentage caused by bodily reaction and exertion compared to total trunk injury or illnesses (data from BLS, 2006a)

Shoulder WMSD prevalence is only one reason they have become the focus of research efforts; associated treatment costs are also of concern. Though the number of total lost workday cases (days away from work plus restricted duty days) is declining, the proportion of restricted duty days is increasing (Figure I.3). Restricted duty days allow workers to remain in the workforce, though their contribution is reduced, resulting in significant costs to organizations.

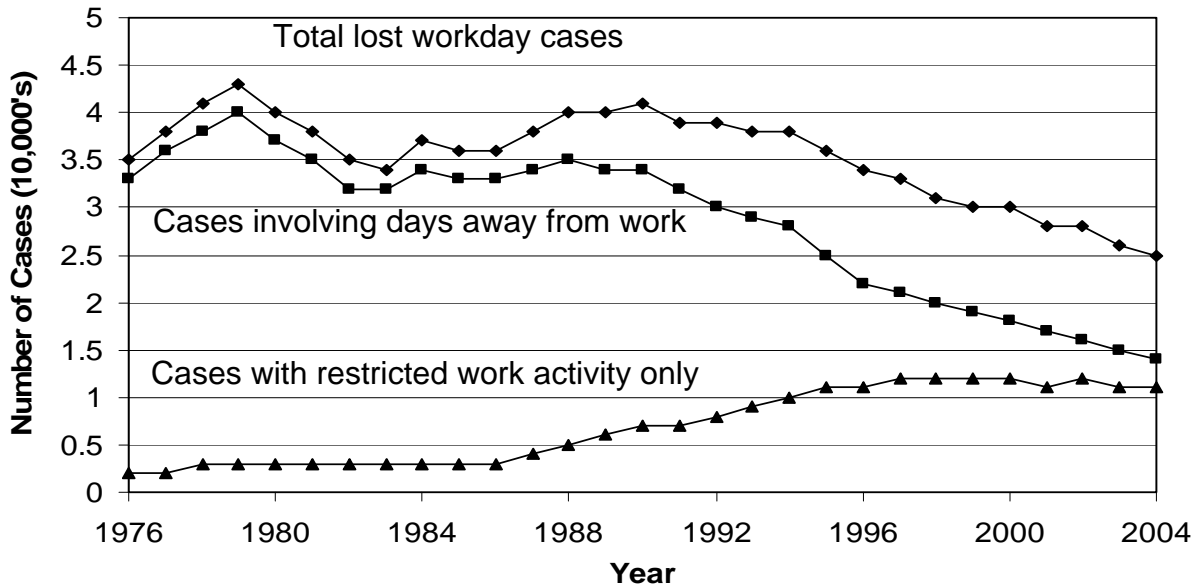

Figure I.3. Lost workday case incidence rates, injuries and illnesses, 1976-2004 (data from BLS, 2001; BLS, 2006b; Ruser, 1999).

Recovery periods vary depending upon the type of shoulder injury or illness. In general, injuries and illness to the shoulder require 17 days away from work (BLS, 2005). Sprains, strains, and tears, the most commonly reported shoulder injuries, have a median of 8 days of recovery, whereas tendonitis requires a median of 13 days. It should be noted that approximately 26% and 33% of sprains, strains, and tears and tendonitis cases respectively require over 31 days away from work (BLS, 2005).

While a significant amount of research has been performed in the area of shoulder WMSDs, knowledge of the underlying pathophysiological mechanisms is limited. Typical analysis methods for high risk jobs include biomechanical analysis, basic ergonomic tools, and various direct measurement techniques, such as electromyography (EMG), video analysis, etc. Due to advances in thermal imaging technology, the use of this technique has expanded from simple heat transfer applications of machine parts to bio-imaging of the human body. Thermography is a non-invasive technique that may provide heretofore unknown physiological markers associated with injury development during job task performance.

1.2 Problem Statement

While current uses of thermal bio-imaging have been useful in identifying normal and abnormal patterns of body-surface heat in healthy and injured persons, the use of thermography for evaluating job tasks and their potential for WMSD development has been limited. Potentially, the effects of job task requirements can be objectively evaluated based on physiological responses, aiding in the development of effective intervention strategies.

Studies have been performed that have assessed the effect of overhead work on muscle fatigue and endurance rates of shoulder and cervical spine muscles using electromyography (EMG). However, no studies found have used thermography to evaluate the significance of overhead work on the musculoskeletal structures of the shoulder. The use of this technology in conjunction with past studies may increase our understanding of physiological responses to loads.

1.3 Objectives of the Study

The objective of this study was to assess anterior deltoid surface temperature changes as a function of shoulder angle and exertion level during static overhead exertions that would be representative of intermittent construction tasks. Specific hypotheses that were tested included:

1. Shoulder angle and exertion level will affect the surface temperature changes over the anterior deltoid. Research has shown that deviated shoulder postures and increased exertions can result in compression of surrounding blood vessels. Thus, the restriction of blood flow to this area will impact thermographic readings.
2. Muscle temperature changes will be related to changes in modified Borg CR-10 ratings over time.

1.4 Scope and Limitations of the Study

The scope of this study was restricted to evaluating changes in surface skin temperature over the anterior deltoid as a function of selected shoulder angles and exertions. Other factors; such as strength, elbow angles, intramuscular pressure, duty cycle, and performance; were not investigated. Elbow and shoulder angles were fixed to ensure moment standardization across shoulder angles.

A single static work task consisting of overhead work was the focus of the research. Other task designs, such as intermittent, dynamic, or other tasks associated with overhead work, were not assessed. In addition, the use of other tools or objects used in manufacturing was not investigated.

CHAPTER II

LITERATURE REVIEW

Overhead work is defined as work in which the hand is above the height of the head (Haslegrave et al., 1997; Herberts & Kadefors, 1976; Nussbaum et al., 2001). Overhead work is common in industries such as construction, agriculture, and manufacturing, usually requiring the use of hand held tools, thereby increasing loads placed on the shoulder (Bjelle et al., 1981). Overhead work is also characterized by requiring persons to maintain deviated shoulder postures for extended periods of time. Static work in deviated postures results in increased muscle fatigue and, after long periods of exposure, an increased risk of injury to the soft tissues of the shoulder (Bjelle et al., 1981; Hagberg, 1984). Understanding the physiological and biomechanical impacts of these factors is important to reduce injury incidence rates.

2.1 Risk factors and potential sources of overhead WMSDs

Occupational risk factors, factors associated with the physical work environment, are the most commonly studied risk factors in WMSD research, primarily to determine work relatedness. Deviated work postures and muscular load are two of the most widely accepted occupational risk factors contributing to shoulder WMSDs. Sufficient epidemiological evidence exists for a causal relationship between shoulder WMSDs and both deviated work postures and muscular load (NIOSH, 1997). Odds ratios as high as 10.6 and 18 have been reported linking posture and force respectively to reported shoulder WMSDs (Hagberg and Wegman, 1987). Due to their prevalence in selected industries, and the inability to implement effective engineering controls to eliminate or reduce exposure to these two factors, they remain the focus of research studies.

2.1.1 Deviated Postures

The shoulder is one of the most complex joints in the human body, providing a large degree of mobility with limited stability (Chaffin et al., 1999). The joint capsule and ligaments provide the majority of stability during movement. Arm movements away from the body increase loads on the shoulder and connective tissues. Neutral posture of the arm is defined as the arm resting alongside the torso (Hagberg and Wegman, 1987; Herberts et al., 1984). Abduction, adduction,

flexion, and extension of the arm are all movements away from neutral, with overhead work requiring significant arm elevation or shoulder flexion.

Arm elevation angle has been cited as the most important factor for determining shoulder load (Sigholm et al., 1984). Bjelle et al. (1981) quantified arm elevations above 60° in either flexion or abduction to be the point at which arm loads exceeded 10% maximum voluntary contraction (MVC) of the shoulder muscles. Load imposed on the shoulder muscles continues to increase with increased shoulder deviation until it reaches the maximum load (largest moment) at a shoulder angle of 90° (Bjelle et al., 1981). These findings are significant since most work does not just involve the weight of the arm, but also the weight of a tool and/or part. Therefore, the loads reported in Bjelle et al (1981) could be considered minimum load requirements. Herberts et al. (1984) noted that when the arm was abducted from 45° to 90°, middle and posterior deltoid muscle activity increased 100%.

Arm elevation angle has several biomechanical implications, the most important of which is argued to be the torque produced on the shoulder joint (Bjelle et al., 1981). A study on overhead drilling identified the optimal position for overhead work is close to the body, because it reduces the shoulder moment (Anton et al., 2001). Increased moments were found to translate into an increase of 5% in root mean squared (RMS) muscle activity levels for every Newton-meter moment increase for the deltoid (Anton et al., 2001). Further, Courey et al. (1998) found that as arm flexion angle increased, external hand forces generated inwards on a box decreased, anterior deltoid muscle activity increased, and participant perceptions of discomfort increased. These results imply the shoulder moments have significant effects on physiological capacities available to perform job tasks, thereby affecting injury risk.

Disrupted blood flow due to arm elevation has also been implicated as a primary injury mechanism associated with overhead work. Hagberg (1984) states the primary pathophysiological mechanisms for shoulder injury in overhead work is impaired blood flow to the tendon due to muscle tension and restricting bones placing pressure on the tendons in the shoulder during sustained arm elevations. Over time, the result of impaired circulation causes muscle ischemia (localized tissue anemia due to impeded blood flow) and reduces strength,

coordination, and endurance (Hagberg, 1982). In an earlier study by Herberts and Kadefors (1976), blood flow impairment was one of the factors thought to produce disorders in the shoulder. Their study on the shipyard welding industry revealed that deltoid and trapezius muscle fatigue was common among inexperienced workers, but absent for experienced workers in prolonged overhead work. Despite the lack of fatigue for experienced workers, the vast majority of workers were forced to retire from overhead welding due to chronic shoulder pain before the age of 60. It is believed that there is progressive impairment of blood supply to the rotator cuff muscles, causing irreparable degeneration with age (Herberts and Kadefors, 1976).

2.1.2 Muscle Load

EMG studies on muscular load have proven to be critical in predicting MSDs and muscular discomfort (Coury et al., 1998). Static loads of 5% MVC have been shown to produce localized muscle fatigue (Sjogaard et al., 1986). Gerdle et al. (1988) found a highly significant linear correlation between mean power frequency (MPF), one metric commonly used to quantify local muscular fatigue, and shoulder flexion at 45, 65, and 90°. As the angle increased so did the anterior deltoid MPF, meaning that with increasing shoulder angles there is an earlier onset of fatigue due to increased muscle loads. Nieminen et al. (1995) imposed loads of 30 to 50% MVC on the shoulder based on the weight of the arm and the suspension of a 4 kg weight at the wrist during a static shoulder flexion task to exhaustion. Fatigue was apparent in the anterior and middle deltoid sooner than other shoulder muscles. The results of this study have significant implications in job design since they illustrate that some muscles fatigue quicker than others. The deltoid muscle is responsible for 49% of muscle torque during arm flexion and, therefore, an important muscle to evaluate when estimating work capacity (Markhede et al., 1985). In a longitudinal study comparing strength and endurance of the shoulder and forearm muscles to deterioration of shoulder-neck-arm status over a year period, strength proved to be an important factor of shoulder-neck-arm status for participants that worked in an automotive motor assembly plant, some of which lead to classifiable disorders (Kilbom, 1988). These participants performed tasks that were mostly dynamic, but involved some overhead static work when handling loads up to 10 kg. An electronics assembly was also studied. Participants in this group performed mostly static tasks where the loads were very small, though no specific load values were provided.

Unlike the automobile assembly task, a relationship could not be demonstrated between strength and deterioration of shoulder-neck-arm status for the electronics group. In both groups, regardless of personal strength capabilities, static elevated work was identified as a risk factor for deterioration of shoulder-neck-arm status.

2.1.3 Elbow Postures

Researchers have pointed out that the angle of the elbow during overhead work has significant implications on the load placed on the structures of the shoulder joint. Only one study was found that investigated the effects of elbow angles on shoulder muscle EMG. Sigholm et al. (1984) found that increasing elbow flexion from 90° to 120° while the arm was in a neutral posture had a slight, though non-significant, effect on normalized shoulder muscle load of the anterior deltoid (EMG increased from 0.66 to 0.71). No studies were found that have investigated the effects of elbow angles on deviated shoulder postures, though it is hypothesized that these effects would be greater due to impacts on shoulder moments.

2.1.4 Hand Activity

When high precision tasks requiring accurate movements are performed, the stabilization of upper extremities creates higher muscle tension in the supporting muscles. Studies investigating hand activity during overhead work are inconclusive. Hand activity has been found to affect muscle activity of the trapezius, but not the middle deltoid during hand precision work when the shoulder was in a neutral posture and the elbow at 90° flexion in the sagittal plane (Roman-Liu et al., 2001). Similarly, anterior deltoid muscle activity of the active arm was not affected by precision, force, or handgrip in a 1994 study by Milerad and Ericson for tasks with subject selected shoulder postures. Precision was found to affect muscle activity of the non-dominant trapezius, infraspinatus, and extensor carpi radialis muscles when the dominant hand was active, possibly indicating that those muscles are primarily supporting muscles and, during precision tasks, require more exertion. Sporrang et al. (1995) found that as the arm is flexed greater than 90° and the elbow is flexed at 90°, muscle activity increased in the middle deltoid during intermittent hand gripping from 30 to 50% MVC. This implies that higher demands on handgrip

forces in elevated arm positions increases the loads placed on the shoulder muscles, and work involving high hand force demands above shoulder level should be avoided.

2.2 Thermography

Thermography is a non-invasive technique that measures the temperature distribution over a surface area (Green, 1987; Harway, 1986; Sherman et al., 1997). In bio-imaging applications, thermography measures skin temperature variations. The skin is the largest thermoregulatory organ; and contains blood vessels in the dermis layer that contribute largely to the control of temperature. When the body is cold or hot, the hypothalamus controls vasoconstriction and vasodilatation of cutaneous blood vessels respectively (Gray, 1995). Injuries to the sub-epidermis structures cause dilation, changing temperatures recorded by thermography. The skin has a heat transfer coefficient of 0.98 and almost directly relates the heat of the vasculature below (Tchou et al., 1992; Uematsu and Long, 1976).

Several studies have been performed that describe experimental requirements for thermographic studies; such as a draft free room, participant equilibrium with the room temperature for at least 20 minutes prior to assessments, and pre examination screening to reduce image abnormalities due to skin surface variations (Green, 1987; Harway, 1986; Herrick and Herrick, 1987; Hubbard and Hoyt, 1985; Sherman et al., 1997; Tchou et al., 1992). Over the years thermal images taken using infrared cameras, liquid crystal thermography, and infrared tympanic thermometer have proven the human body is symmetrical right to left, extremities are cooler, and injuries to nerves, tendons, and muscles produce differentiating temperatures (Green, 1987; Harway, 1986).

2.2.1 Myalgic muscles and blood flow

Unevenly distributed blood flow in many muscles may cause sections of the muscle to react to small blood flow changes (Iversen et al., 1989). Lindman et al. (1991) found that myalgic (painful) muscles had a greater cross sectional area of Type I fibers and a reduced capillary supply than normal muscles. In a chronic trapezius myalgia study by Larsson et al. (1990), blood flow was evaluated to the trapezius muscle fibers and was lower on the painful side compared to the healthy side. Low levels of contraction (less than 20% MVC) have been shown to impair micro circulation through intramuscular pressure and in combination with continuous use of

Type I fibers over time, increasing risk for muscle damage (Bjelle et al., 1981; Larsson et al., 1990; Reneman et al., 1980). Intramuscular pressure that is high enough to restrict the blood flow to the fibers in the muscle causes hypoxia, resulting in muscular fatigue (Bengtsson et al., 1986; Hägg, 1991; Larsson et al., 1990).

2.2.2 Blood Flow Theories

Percentages of isometric contractions causing intramuscular occlusion vary according to different researchers. Barcroft and Millen (1939) found that blood flow is occluded starting at 20% MVC, and Humphreys and Lind (1963) found that total occlusion is found at 70% MVC. Other studies argue that the total occlusion point is closer to 60% MVC (Royce, 1958) or 66% MVC (Start and Holmes, 1963 in Carlson, 1969). In a forearm blood flow study by Lind and McNicol (1967), a three minute sustained contraction was tested at 5, 10, 15, 20, and 30 % MVC and measured with a strain gauge plethysmograph. Blood flow responses at 5% and 10% MVC reached a steady state during contraction, while percentages above 10% MVC did not. At 15% MVC, the blood flow trend did not match either the high MVC group (20% and 30% MVC) or the low MVC group (5% and 10% MVC). However, post-exercise hyperaemia trends were similar for 5, 10, and 15%. For 20% and 30%, post-exercise hyperaemia showed larger blood flows than during the contraction due to a blood deficit during the exercise. The deficit is due to an insufficient supply of blood to the muscle, resulting in lactic acid build up leading to the inability of the muscle to exert force and thus fatigue occurs.

During repetitive static exercise of shoulder muscles there is a decrease in blood flow to the skin along with an increase in blood flow to the muscle (Larsson et al., 1995). Hagberg (1981) estimated the torque produced by arm elevations of 90° to exceed 10% MVC. Static contractions above 10% MVC are known to inhibit blood flow to the muscles, and are believed to be a main causal factor of fatigue (Hagberg, 1992; Jarvholm et al., 1991; Larsson et al., 1995; Lind and McNicol, 1966). Blood flow impairment is partial until 20% MVC where occlusion of macro blood circulation is present due to the intramuscular pressure exceeding blood pressure (Barcroft and Millen, 1939; Elert et al., 1991; Humphreys and Lind, 1963; Royce, 1958; Start and Holmes,

1963). Arm elevation and muscular load are related to blood flow impairments and fatigue, but a precise correlation does not exist.

2.2.3 Current Thermography Research and Applications

Neurothermography, thermography of the peripheral nervous system, has effectively identified the presence of carpal tunnel syndrome (CTS) (AMA Council on Scientific Affairs, 1987; Green, 1987; Herrick and Herrick, 1987; Oerlemans et al., 1999; Tchou et al., 1992), as well as other neurological and neuromuscular disorders of the cervical spine and upper extremity (Feldman and Nickoloff, 1984; Jeracitano et al., 1992; Pogrel et al., 1996; Sherman et al., 1997; Zhang et al., 1999). Results of these studies are consistent in that persons with dysfunctions affecting soft tissues of the body (nerves, tendons, muscles, etc.) have asymmetrical thermal images.

During the first 90 days of an injury to peripheral nerves, skin temperature is higher on that side of the body, followed by a distinct reduction in surface temperature patterns that may remain detectable for years (Green, 1987). Inflammation of the tissues under the skin usually produces heat except when there is edema impeding blood flow (Hobbins, 1982). Asymmetrical temperatures indicate signs of injury, and increased thermographic readings on an individual's left or right side preface feelings of pain (Sherman et al., 1997). Dysfunctional neural segments can also be diagnosed by comparing skin temperatures over time and change in environmental temperature (Green, 1987).

2.2.4 Limitations in Using Thermography

Thermography has been found to be effective in diagnosing injuries of the musculoskeletal system. However, there are several limiting factors. Smoking has a biasing effect on the thermal images. Tobacco use restricts blood circulation by vasoconstriction and lowers body temperature (Gershon-Cohen et al., 1969 in Feldman and Nickoloff, 1984). Participants can be smokers, but cannot have smoked on the day of the experiment to reduce these biasing effects (Feldman and Nickoloff, 1984). Superficial abnormalities, such as lacerations, dermatitis, focal psoriasis (chronic skin disease causing symptoms in other areas of the body), and congenital hemangiomas (also known as varicose veins) of two digits produce asymmetrical images (Feldman and Nickoloff, 1984). Subcutaneous fat can affect symmetry of the thermal image

(Frim et al., 1990). Since subcutaneous fat is distributed non-uniformly, the participants selected must have a low body fat percentage and have symmetrical fat content. Females have a higher percentage of body fat that affects thermography readings as well as menstrual cycles that also affect temperatures (Petrofsky et al., 1975). Other health conditions such as cancer, age, and surgery can cause asymmetrical images (Tsuchida, 1990). Cancer causes abnormal growths in various areas, as the body gets older the body deteriorates non-uniformly over time, and surgery changes the structure of the affected area; all of which can result in asymmetrical temperature patterns.

2.3 Summary

Previous literature on working heights and muscular load presents data and results that support causal factors that produce shoulder WMSDs. Shoulder angles larger than 60° produce significant torques on the shoulder increasing muscle loads and impairing blood flow to the shoulder muscles. Thermography is gaining acceptance as a diagnostic tool for disorders of the soft tissues. Evaluating changes in skin surface temperature during work may prove valuable in injury prevention. The use of thermography in evaluating job tasks is limited if not non-existent. A single study has shown that there may be a considerable link between EMG and thermographic readings, though the objective of this study was injury diagnosis not task evaluation (Uematsu et al., 1981). Thermography has the potential to link blood flow impairment, MVC, and biomechanics together and produce a vital tool for ergonomic analysis.

CHAPTER III
METHODOLOGY

3.1 Experimental Design

A laboratory study using a three factor, mixed subject design, was used to assess the effects of shoulder height and exertion level on anterior deltoid thermographic readings. Order of the experimental conditions was balanced with repeated Latin squares (Table III.1) repeated across gender.

Table III.1. The presentation order; balanced with repeated Latin squares.
S = Shoulder Angle, E = Exertion Level

Participant	Sex	S1 / E1	S2 / E1	S1 / E2	S2 / E2
1	Male	1	2	4	3
2	Male	2	3	1	4
3	Male	3	4	2	1
4	Male	4	1	3	2
5	Male	1	2	4	3
6	Female	1	2	4	3
7	Female	2	3	1	4
8	Female	3	4	2	1
9	Female	4	1	3	2
10	Female	1	2	4	3

3.2 Independent Variables

Three independent variables were investigated including shoulder angles, exertion level, and gender.

3.2.1 Shoulder Angle

Work height was set to obtain shoulder angles of 90° and 115° based on participant anthropometrics. These angles were selected based on previous literature of common shoulder angles observed from welders and pear pickers (Herberts et al., 1984; Kadefors et al., 1976; Sakakibara et al., 1995). Elbow angles were set so that the lower arm was perpendicular to the floor, resulting in elbow angles of 90° and 115°.

All simulated overhead work was performed on an adjustable height and distance overhead apparatus (Figure III.1) with a force transducer attached to a handgrip for data collection. The camera was adjusted so that the view of the anterior deltoid is directly in front of the camera lens. Participants were positioned using pre-placed footprints and arm posture changes were minimized using hanging bells adjusted to bicep height auditory and sensory reminders. Back posture was controlled by an adjustable support located in front of the participant to prevent trunk flexion or extension. The chest support was adjusted horizontally and vertically, and participants were required to maintain contact throughout testing. Support location was standardized for all test sessions for each participant. Arm segment lengths required to calculate apparatus set up were derived by interpolating link length percentiles (Table III.2).

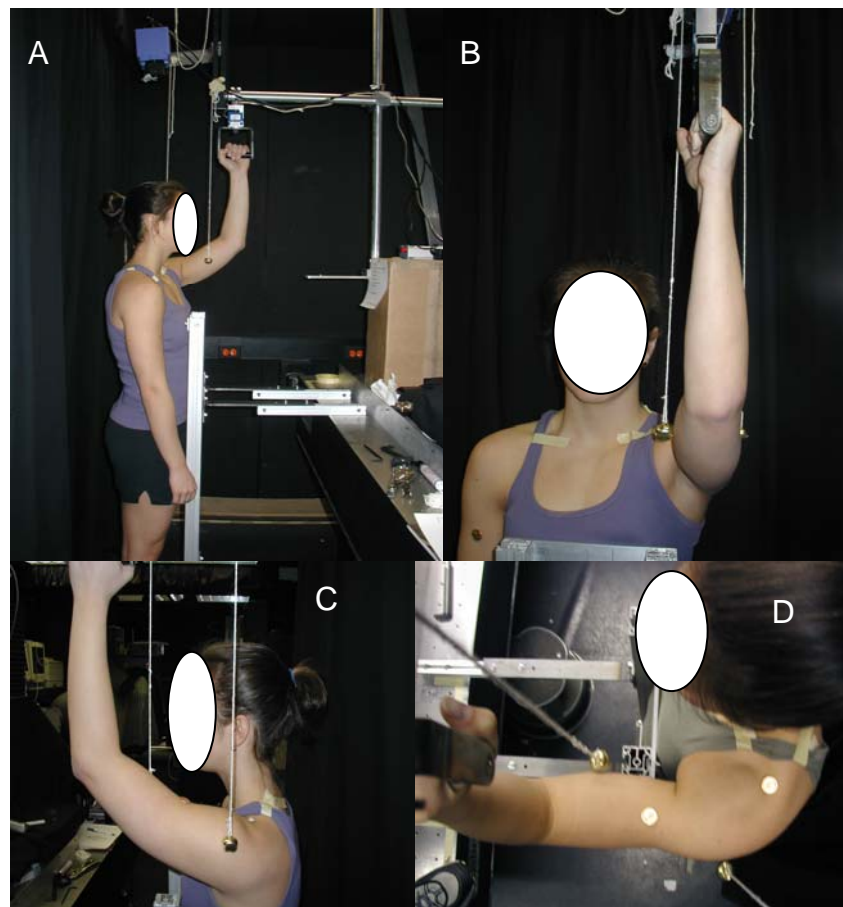

Figure III.1. Testing apparatus: (A) Left side image, (B) Frontal image, (C) Right side image, (D) Overhead image

Table III.2. Link Length Percentiles, measurements in meters (m)
¹(Webb Associates, 1978) ²(Kroemer, 1994)

Percentile	Male			Female		
	5%	50%	95%	5%	50%	95%
Upper Arm ¹ (UA _p)	0.286	0.304	0.323	0.261	0.278	0.295
Lower Arm ¹ (LA _p)	0.256	0.275	0.292	0.227	0.241	0.255
Hand ² (H _p)	0.1787	0.1938	0.2106	0.165	0.1805	0.1969

UA_p=Upper Arm length percentile, LA_p=Lower Arm length percentile, H_p=Hand length percentile

The centers of mass (COM) for individual segments of the arm are needed to calculate the moment. The previous calculated length percentiles (UA_p, LA_p, LA_p) are used to calculate the center of mass by interpolating link length percentiles (Table III.3).

Table III.3. Distances to Center of Mass (COM), measured in meters (m)
(Dempster, 1955)

Percentile	Male			Female		
	5%	50%	95%	5%	50%	95%
Upper Arm (Shoulder to UA _{com})	0.125	0.132	0.14	0.116	0.121	0.125
Lower Arm (Elbow to LA _{com})	0.110	0.117	0.123	0.099	0.104	0.110
Hand (Wrist to H _{com})	0.067	0.070	0.074	0.061	0.064	0.067

UA_{com}=Upper Arm Center of Mass (m), LA_{com}=Lower Arm Center of Mass (m), H_{com}=Hand Center of Mass (m)

Webb Associates (1978) estimated that the arm is 5.1% of the total body weight, with the upper arm constituting 54.9%, lower arm 33.3%, and hand 11.8% of that percentage. To find the Arm Mass (A), Upper Arm Mass (UA_m), Lower Arm Mass (LA_m), and Hand Mass (H_m) equations 3.1 through 3.4 are used.

$$\text{Arm: Total Body Weight} * 5.1\% = A \quad (3.1)$$

$$\text{Upper Arm: } 54.9\% * A * 9.81 = \text{UA}_m \quad (3.2)$$

$$\text{Lower Arm: } 33.3\% * A * 9.81 = \text{LA}_m \quad (3.3)$$

$$\text{Hand: } 11.8\% * A * 9.81 = \text{H}_m \quad (3.4)$$

Where:

$$\text{Upper Arm Mass (N)} = UA_m$$

$$\text{Lower Arm Mass (N)} = LA_m$$

$$\text{Hand Mass (N)} = H_m$$

$$\text{Gravity (N)} = 9.81 \text{ m/s}^2$$

Once all the dimensions and weights are computed, they will be used to calculate the moment on the shoulder. To find the moment at the shoulder (M_S), first the moment at the elbow must be calculated (M_E) as shown in equation 3.5.

$$M_E = (LA_m \times (LA_{com} \cos (180 - E))) + (H_m \times ((LA \times \cos (180 - E)) + H_{com} - H_f)) \quad (3.5)$$

Where:

$$\text{Lower Arm Length (m)} = LA$$

$$\text{Hand Length (m)} = H$$

$$\text{Elbow Angle} = E$$

$$\text{Hand Force (N)} = H_f$$

Finally, to find the moment at the shoulder (M_S), equation 3.6 is used.

$$M_S = (UA_m \times (UA_{com} \cos (S - 90))) + ((H_m + LA_m) \times (UA \times \cos (S - 90))) + M_E \quad (3.6)$$

Where:

$$\text{Upper Arm length (m)} = UA$$

$$\text{Shoulder Angle} = S$$

A visual depiction of the equation is located in figure III.2.

Shoulder Angle 1

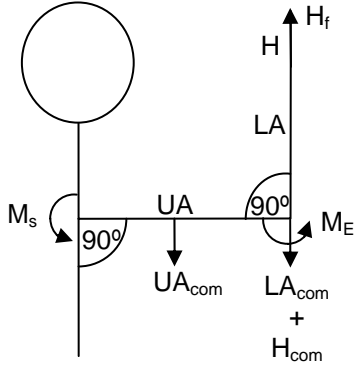

Shoulder Angle 2

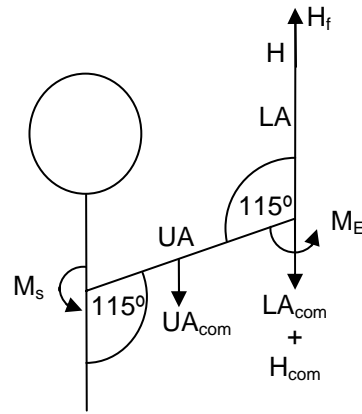

Figure III.2. Shoulder angle free body diagrams

To find the horizontal distance from the acromion to the force transducer, force transducer placement (FP) is calculated in equation 3.7.

$$FP = (UA \times \cos (S - 90)) + (LA \times \cos (180 - E)) + (.5 \times H) \quad (3.7)$$

To find the vertical distance from the floor to the force transducer apparatus height (AH) is calculated in equation 3.8.

$$AH = (UA \times \sin (S - 90)) + (LA \times \sin (180 - E)) + Ac \quad (3.8)$$

Where:

$$\text{Acromion height (m)} = Ac$$

3.2.2 Exertion Level

Two exertion levels were evaluated, 15% and 30% MVE. These exertions included weight of the arm. Exertions were monitored using a handgrip attached to a force transducer, capturing unfiltered data at 100Hz, coupled with a digital force readout on an amplifier. Raw data was processed by LabVIEW 7 Express and saved for later analysis. Placement of the force

transducer was perpendicular to the shoulders and parallel to the arm of the participant. Exertion levels for each arm were calculated from daily maximum voluntary exertion (MVE) assessments. Participants exerted an upward force on the force transducer while gripping an attached handle without changing arm, hand, and back postures. Visual queues (digital readout) and verbal queues (experimenter confirmation) were used to notify participants when they have reached the desired exertion level and to ensure participants did not exceed or fall below the desired exertion level by 5% for more than three seconds.

3.2.2.1 Maximum Voluntary Exertions

MVEs of each arm were performed to allow for estimation of maximum force levels of the anterior deltoid muscle. Anterior deltoid MVEs were assessed at each session with the apparatus adjusted to session conditions (shoulder and elbow angles). Anterior deltoid MVEs for the task condition were estimated by requiring participants to exert upward force against the force transducer on the overhead platform. Five successful six-second MVEs were performed for each muscle on each day of testing (Form 4, Appendix A). Five MVEs were required because the MVEs do not isolate the anterior deltoid but are condition dependant. A 6-second “ramp-up, hold, ramp-down” cycle for MVE measurement was used. More than five MVEs were collected if the last exertion was the maximum. The maximum value of the trials was kept as the participants true MVE. Peak force values obtained during these MVEs were used to normalize force data obtained during the experimental trials.

The exertion levels were calculated by taking MVE values from each session as described above and adding the force required to position the arm on the handle (total MVE). Participants gripped the handle then rested the arm for three, five second data collection periods. The average of all three force measurements was calculated and added to the task MVE collected previously, providing a total MVE value. This procedure (total MVE) was used due to the required force needed to suspend the arm.

3.3 Dependant Variables

Two objective and one subjective dependent variable were investigated. The objective measures were thermography temperature readings (mean slope and intercept temperature values) of the anterior deltoid and endurance time. The subjective measure was a modified version of the Borg CR-10 rating of perceived exertion scale using discomfort ratings slopes (Form 7, Appendix A).

3.3.1 Thermography

Thermography was used to measure skin temperature patterns during the experiment.

Thermography was collected with the Electrophysics PV320T2 infrared camera in a controlled temperature room at approximately 22.5°C.

During each testing session four thermal imaging sequences were collected: baseline, first experimental arm, secondary baseline, and second experimental arm. For all images, acromion and the anterior deltoid insertion (identified by palpation) on each side were marked with a henna tattoo to ensure consistent data collection throughout all sessions. Four polished copper pennies, used as focusing markers, were placed on the participant's tattoos for focusing the camera and locating the area for measurement. Baseline data was collected by having the participant stand in an upright and neutral posture with feet shoulder width apart (while wearing shoes) 1.5 meters horizontally away from the lens of the camera centered between the participant's feet, preceded by a 15 minute acclimation period. Images were recorded at 1Hz for the final 3 seconds of the 15 minute period. The second frame was used to ensure symmetry of the shoulders prior to testing and to reduce experimental error associated with camera start up and shut off effects. Symmetry was determined using Velocity 1.1 software analysis tools. Two areas with the same size were placed between the 2 pennies on each arm capturing temperatures for approximately 50% of the muscle belly (Figure III.3).



Figure III.3. Temperature comparison between the two anterior deltoid regions

Since both arms were tested in a single session, baseline data was collected to ensure participants began testing of the second arm at an equivalent state. A secondary baseline was performed following 20 minutes of rest after the completion of the first experimental condition using the same procedures. Secondary baseline values for the untested shoulder were required to be within 1° C of baseline before testing could continue.

First and second experimental arm assessments required the camera to be positioned according to participant anthropometrics. The camera was 0.5 meters away from the shoulder allowing for full visualization of the anterior deltoid and adjusted to ensure that both pennies were clearly visible. Data was sampled at 1Hz using Velocity 1.1 software package and stored on a PC.

Thermographic images were analyzed by dividing an assessment region overlaid on the thermal images into six equally sized segments around a midline between the two markers. The width of the assessment region was set to 25% of the pennies diameter, and this was determined using pilot testing (Figure III.4). This assessment width minimized the effects of surrounding musculature. Mean temperature values for each area were determined for the entire test session

and a linear regression line was fit to that data. Generated slope and intercept values were used in data analysis.

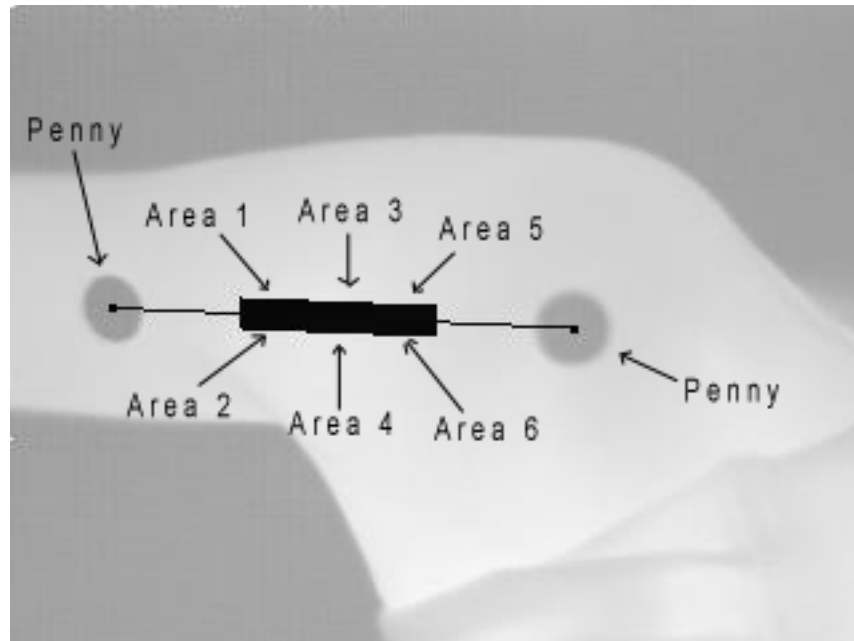

Figure III.4. Detailed area picture of the areas on the right arm in relation to the penny

3.3.2 Endurance Time

Endurance time was the time to failure. This time was measured from the onset of the exertion until the participant could not exert the required force. Participants either self terminated the session, or were asked to stop when they could not maintain the desired exertion level for three seconds with verbal reminders and encouragement.

3.3.3 Discomfort Rating

A modified Borg CR-10 Perceived Level of Exertion Scale, from 0 = none at all to 10 = very, very high (almost max), was used to quantify discomfort during each task condition (Borg, 1982) (Form 7, Appendix A). The scale was posted in front of the participant at eye level during the experiment. Participants were asked to verbally provide a discomfort rating every 30 seconds for the duration of the test (Form 5, Appendix A). Discomfort rating data was fit with linear regression techniques and slope values were used in data analysis procedures.

Additionally, a “General Body Visual Analog Discomfort Scale” (Visser and Straker, 1994) was used to obtain discomfort data for various body parts (Form 6, Appendix A) following each experimental condition. The scale is a 100mm line with anchors (no discomfort and extreme discomfort). Participants made a single vertical mark across the scale for each body part. To determine the discomfort rating, the distance from no discomfort was measured in millimeters and the number was recorded as the discomfort level from 0 to 100. Participants were asked to complete a “General Body Visual Analog Discomfort Scale” following each experiment.

3.4 Testing Environment

The experiment took place in a draft free room that had black walls to prevent reflection that would bias thermal images. Indirect lighting measuring less than 5 lux was used to prevent error in thermal imaging data collection but allow for the participant to orient themselves.

Temperature measurement of the room was recorded before the first experiment in each session.

3.5 Task

Participants were asked to perform forward flexion of one arm such that the posture of the shoulder and elbow meet the experimental condition. Participants gripped the handgrip and applied a continual constant upward force to the force transducer located on the overhead apparatus until the participant could no longer maintain the required exertion level (exhaustion). Participants remained in the correct posture throughout the experiment until exhaustion to prevent postural biases. After a minimum 20-minute rest period and when the untested arms skin temperature reached baseline, the participant repeated the condition on the opposite arm. The order for arms tested was randomized across participants and sessions (Appendix A, Table A.1.).

Four successive experimental sessions were conducted with a minimum of 48 and a maximum of 72 hours between all experimental sessions to allow for sufficient rest and recovery and to minimize residual fatigue. Additionally, participants were required to submit to testing at the same time of the day for all experimental sessions due to circadian rhythm and hydration level differences (Miyakoshi et al., 1998). Participants were compensated \$7/hr for actual time

completing experimental protocols. Test sessions and the screening session lasted approximately one hour and two hours respectively.

3.6 Participants

Ten healthy, non-smoking participants, two left and eight right handed, completed the experiment. Five male and five female participants ranged from 19 to 24 (mean = 20.50; median = 20; sd = 1.78) (Table III.4). Exclusion from participation was based on a screening session consisting of a symptoms questionnaire (Forms 1 and 2, Appendix A), a visual inspection of the shoulder area, body fat assessment via Bioelectrical Impedance Analysis (BIA), and a symmetrical thermal image test. Each procedure was completed by a single researcher in a private room.

Table III.4. Descriptive statistic means and standard deviations of the participants

Variable	All Participants	Males (5)	Females (5)
Weight (kg)	59.00 (8.41)	64.48 (4.58)	53.52 (7.95)
Height (m)	1.69 (0.08)	1.75 (0.07)	1.64 (0.06)
Body Fat (%)	15.80 (3.54)	12.96 (2.13)	18.64 (1.88)
Age (yr)	20.50 (1.78)	19.8 (1.10)	21.2 (2.17)

None of the participants had sustained musculoskeletal problems that might have hindered their performance on the experimental task. (See Appendix B, Table B.1 for a full description of participant demographics). Participant descriptive data was compiled and used to calculate the work location for each participant as detailed in Appendix B, Table B.2.

3.6.1 Screening Procedure

Participants were asked to perform the screening session measurements just before lunch, or at least 4 hours after lunch to ensure accurate body fat analysis results due to hydration levels that effect body fat fluctuations (Tanita Corporation, 2001). Participants were screened for musculoskeletal pain or disorders affecting the upper extremities and shoulders by using a custom symptoms questionnaire (Forms 1 and 2, Appendix A). Participants were excluded if they reported any previous shoulder disorders or symptoms within the past year. Participants

changed into a dark tank top shirt and shorts to allow for clear visualization of the area. A visual inspection of the shoulder area was used to identify various marks, scars, or other blemishes in the skin of the shoulder area that may influence or bias the results.

A BIA scale (TBF-612 Personal Model, Tanita Corporation) was used to collect weight and body fat percentiles to reduce potential confounding effects of body fat on thermal readings (Frim et al., 1990). Participants were required to have body fat percentages lower than or equal to the 50th percentile for males or females between 20-29 years of age to continue the screening process (Table III.5). This ensured that the participants are slightly healthier than average and that fat thicknesses would not interfere with the thermal imaging (Frim et al., 1990). During BIA, participants were instructed to remove their shoes and socks, cleanse their feet with soap and water in a shallow tub, completely dry off their feet, and then stand still on the scale with both feet making contact with the electrodes. To ensure that accurate BIA measurements were obtained, participants were asked to adhere to the following procedures (American College of Sports Medicine, 2000, pp 66):

1. Abstain from eating or drinking four hours prior to the assessment;
2. Avoid moderate or vigorous physical activity 12 hours prior to the assessment;
3. Abstain from consuming alcohol 48 hours prior to the assessment;
4. Abstain from ingesting diuretics, including caffeine, prior to the assessment;
5. An empty bladder prior to the assessment; and
6. Remain in an upright standing posture with knees locked, arms to the side, and facing forward when measuring.

Table III.5. Body fat percentiles for males and females of 20-29 years of age. (American College of Sports Medicine, 2000)

Percentile	Males	Females
90	7.1	14.5
80	9.4	17.1
70	11.8	19.0
60	14.1	20.6
50	15.9	22.1
40	17.4	23.7
30	19.5	25.4
20	22.4	27.7
10	25.9	32.1

Finally a thermal image screening test was performed to check for symmetry. The camera was positioned based on four anthropometric measurements (standing height with and without shoes, and right and left acromion heights) (Form 3, Appendix A) so that it was at the participants chest height and parallel to the ground. Heights were taken with an anthropometer and the participant stood upright in a neutral posture and feet shoulder width apart. The acromion height, while wearing shoes, for each side was measured vertically from the acromion process to the ground (Chaffin et al., 1999). Standing height, with and without shoes, was measured vertically from the apex of the head to the ground. A thermal symmetry test was performed using the same procedures as detailed previously. Participant images had to have symmetrical temperatures within 1° C accuracy, to continue with experimentation. To keep the thermal image data unbiased, females were not used in this experiment if they were menstruating (Petrofsky et al., 1976).

Anthropometric measurements of the upper arm, lower arm, and hand were measured and used in calculating the height of the task apparatus. Upper arm length was measured from the glenohumeral and elbow joint centers of rotation (Chaffin et al., 1999). The glenohumeral joint center of rotation is located at the midregion of the palpable bone mass of the head and tuberosities of the humerus. The elbow joint center of rotation is located midway between the lowest palpable point on the medial epicondyle of the humerus and the point 8 mm above the radiohumeral junction (Chaffin et al., 1999). Lower arm length was measured from the elbow and wrist joint centers of rotation. The wrist joint center of rotation is located on the palmar side of the hand where the wrist creases at the palmaris longus tendon (Chaffin et al., 1999). The hand was measured from the wrist joint center of rotation and tip of the longest finger.

Anthropometric measurements of acromion distance and inter-feet distance were measured (Form 3, Appendix A) to aide in positioning participants for testing. Acromion distance was measured horizontally from the right acromion process to the left acromion process (Chaffin et al., 1999). The feet, shoulder width apart (while wearing shoes), were traced on a black piece of paper with a pencil and saved for future sessions to avoid posture and balance bias (Haslegrave et al., 1997). The medial and lateral malleolus are also marked for each foot to determine the midpoint of the foot. The distance between the two midpoints is measured, and compared to the

acromion distance to aid in positioning the participant so that the anterior deltoid was fully visible during imaging. Acromion distance was also used to position participant's arms so that they were in the same plane as the force transducer.

3.6.2 Familiarization Session

Participants passing screening completed a 15-minute task familiarization session. The familiarization session included one acceptable MVE, arm force measurement, and one cycle of the task at a high force level and a random shoulder angle for one randomly selected arm. Following the completion of the familiarization session, participants were scheduled to return for four experimental sessions starting a minimum of 48 hours later.

3.7 Procedure

Initially, participants were provided with a verbal and written description of the project, its objectives, and the procedures and completed informed consent documents approved by the Virginia Tech Institutional Review Board. Participants wore a dark tank top shirt, shorts, and the same shoes worn in the screening session during all experimental sessions. Females were asked to wear a brassiere that does not interfere with the anterior deltoid, shorts, and a dark tank top. After entering the experimental room, sessions began with the arm force and MVE trials, followed by a 15 minute acclimation period and baseline imaging.

Participants core temperature was taken with an digital oral thermometer. Participants then stepped into their footprint outline, grabbed the handgrip attached to the force transducer, and began exerting a constant force upwards providing subjective discomfort ratings until exhaustion. At then end of the first test, participants completed the "General Body Visual Analog Discomfort Scale", rested for 15 minutes seated then stood for 5 minutes. The secondary baseline image was collected and compared to the first image and if the arm was at a resting state, completed the test on the second arm followed by completion of the "General Body Visual Analog Discomfort Scale." These procedures were repeated for each test session and participants were compensated for their time following each session.

3.8 Statistical Analysis

Appropriate descriptive statistics (e.g. means, standard deviations, etc.) for each dependant variable (e.g. slope and intercept temperature values of the anterior deltoid, endurance time, and modified Borg CR-10 discomfort rating slopes) were calculated. Normality tests, correlations, Analysis of Variance (ANOVAs), and an Analysis of Covariance (ANCOVA) were performed on the dependant variables. A power analysis was performed following data collection.

3.8.1 Normality Tests

Linear regression was used to estimate slope and intercept values of the dependant variables (temperature and modified Borg ratings) and used for evaluating the effects of shoulder angles, exertion levels, and treatment conditions on thermal readings.

Shapiro-Wilk normality tests ($p=0.05$) were performed on all continuous data (endurance time, temperature slopes and intercepts, and modified Borg slopes) to ensure that normality conformed.

3.8.2 ANOVA, ANCOVA, and Correlations

Repeated measures ANOVAs were used to test for the effects of shoulder, exertion, gender, and arm on endurance times and modified Borg slopes. A repeated measure ANCOVA was used to test for the effects of shoulder, exertion, gender, and arm on temperature slopes with co-variables (body fat, and room and core temperature). Tukey's least significant difference (LSD) pairwise multiple comparison test was used for treatment conditions if a significant finding was identified. All findings were considered significant at an $\alpha=0.05$. Temperature slope values were correlated with modified Borg ratings and endurance time to determine if there were relationships.

CHAPTER IV

RESULTS

Descriptive statistics for the dependant variables endurance time, modified Borg rating slope, and temperature slope are located in Table IV.1. In general, females were found to have longer endurance times and discomfort levels increased at a slower rate than males. Also, the higher exertion level and the 90° shoulder angle resulted in shorter endurance times; and exertion level had a positive relationship with all dependant variables.

Table IV.1. Descriptive statistic means and standard deviations for dependant variables

Variable		Endurance Time (s)	Borg Slope	Temperature Slope (°C/s*)
Gender	Male	244.06 (104.40)	3.01 (1.08)	3.24 (1.97)
	Female	292.08 (92.85)	2.31 (0.88)	3.06 (1.72)
Arm	Dominant	275.19 (105.20)	2.78 (1.07)	3.08 (1.96)
	Non-dominant	260.94 (97.64)	2.54 (1.00)	3.22 (1.73)
Exertion	15%	335.98 (83.95)	2.05 (0.84)	3.09 (1.75)
	30%	200.16 (64.76)	3.26 (0.85)	3.21 (1.94)
Shoulder	90°	249.95 (85.53)	2.71 (1.06)	3.30 (2.07)
	115°	286.18 (112.76)	2.60 (1.02)	3.00 (1.58)
Condition	S1/E1	310.17 (66.12)	2.26 (1.01)	3.21 (1.82)
	S2/E1	361.79 (93.23)	1.85 (0.58)	2.97 (1.68)
	S1/E2	189.74 (54.87)	3.17 (0.92)	3.40 (2.30)
	S2/E2	210.57 (73.28)	3.35 (0.79)	3.03 (1.48)

Note: S1 = 90°, S2 = 115°, E1 = 15%, E2 = 30%; * Measured in thousandths of a °C

Experimental conditions were balanced with repeated Latin squares and order effects were tested. ANOVA and ANCOVA results indicated that order effects were not significant for mean slope temperatures, endurance times, and modified Borg slope values.

4.1 MVE

MVEs were calculated at the beginning of each experimental session (Table IV.2) to set the exertion requirements for the task. Males had significantly higher MVEs than females and the 90° shoulder angle resulted in significantly lower MVEs than the 115° angle.

Table IV.2. Participant shoulder angle MVE means and standard deviations for each arm and gender

	Arm	Shoulder	Total MVE (N)
Male	Dominant	90°	197.07 (22.83)
		115°	211.31 (22.62)
	Non-dominant	90°	173.41 (17.38)
		115°	183.94 (24.49)
Female	Dominant	90°	120.20 (20.46)
		115°	120.30 (19.26)
	Non-dominant	90°	106.33 (17.09)
		115°	116.80 (26.61)
Overall	Dominant	90°	158.64 (44.73)
		115°	165.81 (50.97)
	Non-dominant	90°	139.87 (38.28)
		115°	150.37 (42.49)

4.2 Experimental Duration

Mean experimental durations were found to be significantly different across exertion levels ($p \leq 0.0001$) and shoulder angles ($p = 0.0008$), though the interaction was not significant. The mean experimental duration for the 15% exertion level (335.98 s) and the 115° shoulder angle (286.18 s) were longer than the 30% exertion level (200.16 s) and the 90° shoulder angle (249.95 s).

4.3 Temperature Data

Figures IV.1 and IV.2 provide examples of the time dependency of thermal readings for a both arms of a single participant for all conditions. As can be seen in the figures, temperature increased throughout the test session. Intercept analysis was removed due to the inability to standardize intercepts across participants.

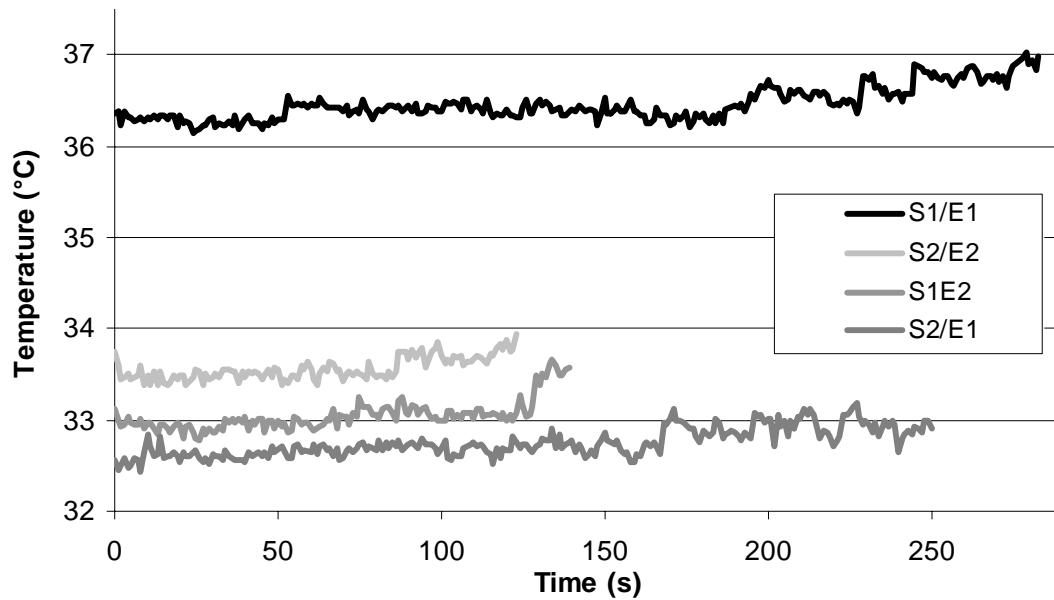

Figure IV.1. Area 3 dominant arm temperature data for each experimental condition.

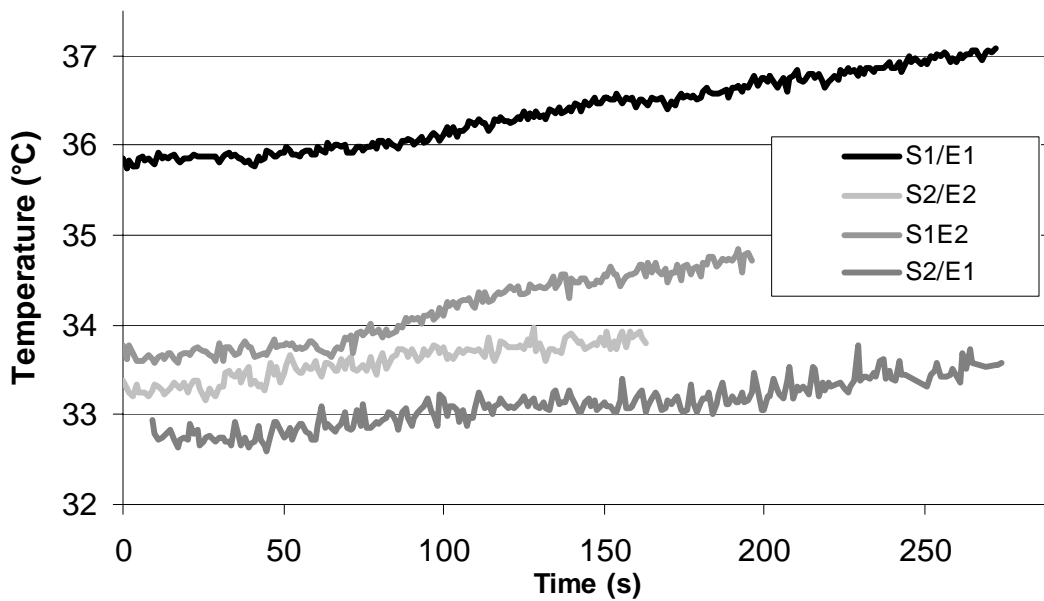

Figure IV.2. Area 3 non-dominant arm temperature data for each experimental condition.

Analysis of the six individual assessment areas revealed that slopes did not differ significantly ($p=0.8526$) (Figure IV.3). Since area differences were not significant, two other divisions were considered. Position, defined as medial/lateral, consisted of three regions each; and distance;

defined as origin, middle, and insertion; consisted of two regions each. Position was not found to be significant. Distance was found to affect slope parameters when interacting with arm ($p=0.0493$).

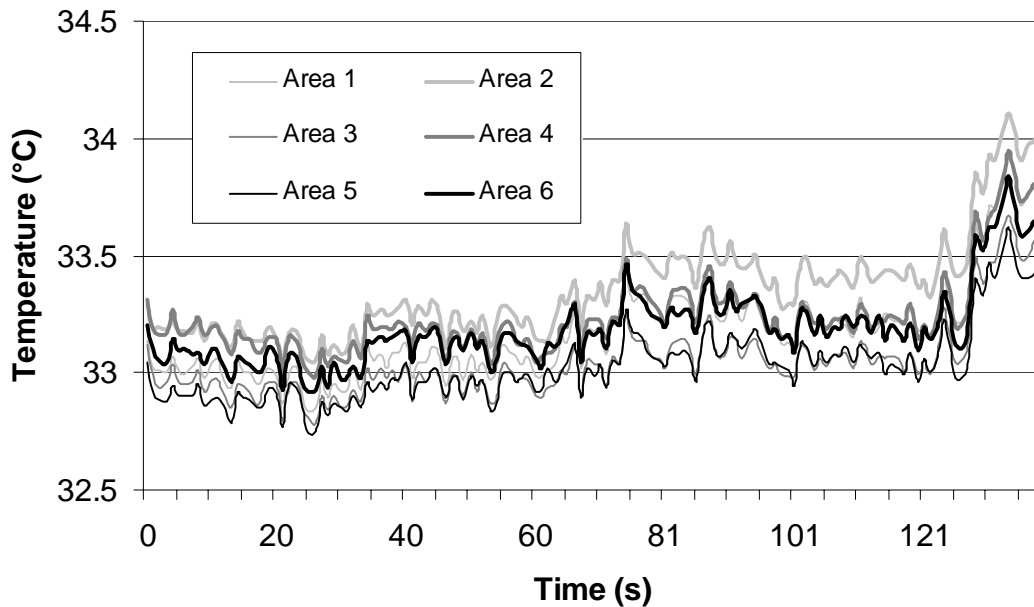

Figure IV.3. Condition S1/E2 dominant arm temperature data

An ANCOVA for temperature slopes was performed and variable of interest are located in Table IV.3. The full ANCOVA is located in Appendix B, Table B.3. There were significant differences in temperature slope values for shoulder angle ($p=0.0041$). The interactions of arm and shoulder angle ($p=0.0021$) and arm and gender ($p<0.0001$) were also significantly different for temperature slope.

Slopes were found to be significantly affected by shoulder angle and the interactions shoulder angle by arm, arm by distance, and arm by gender (Table IV.3). The 90° shoulder angle resulted in significantly faster temperature changes than the 115° shoulder angle. The 90° shoulder angle for the non-dominant arm resulted in significantly faster temperature changes than the other combinations, and no other differences were found (Table IV.4 and Figure IV.4). Tukey's results were inconclusive for the arm by distance interaction, though a general trend was observed. In general, as one moves from origin to insertion slopes for the dominant arm increased while slopes for the non-dominant arm decreased (Table IV.5 and Figure IV.5). Males

were found to have higher slope values for the dominant arm, while females had higher slope values for their non-dominant arm (Table IV.6 and Figure IV.6).

Table IV.3. Temperature slope ANCOVA for each shoulder angle, exertion level, arm, distance, position, time, and their interactions of interest

Effect	p-value	Effect	p-value
Shoulder	0.0041	Shoulder x Gender	0.2159
Exertion	0.1562	Exertion x Gender	0.3432
Shoulder x Exertion	0.5523	Shoulder x Exertion x Gender	0.2079
Arm	0.2760	Arm x Gender	<.0001
Shoulder x Arm	0.0021	Shoulder x Arm x Gender	0.8831
Exertion x Arm	0.1781	Exertion x Arm x Gender	0.2476
Shoulder x Exertion x Arm	0.5822	Arm x Distance x Gender	0.0637
Distance	0.7265	Body Fat	0.9002
Arm x Distance	0.0493	Room Temperature	0.0040
Position	0.2435	Core Temperature	0.0013
Gender	0.9958		

Shaded regions are significant (alpha = 0.05)

Table IV.4. Post-hoc arm by shoulder angle comparisons for mean temperature slope

Arm	Shoulder	Mean (°C/s*)	Grouping
Non-dominant	90°	3.58	A
Dominant	115°	3.10	B
Dominant	90°	3.07	B
Non-dominant	115°	2.85	B

* Measured in thousandths of a °C

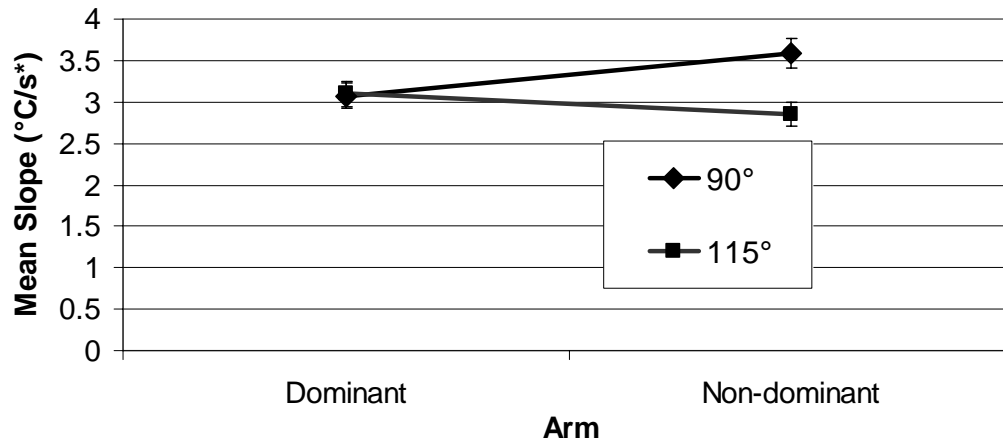

Figure IV.4. Mean temperature slope for arm by shoulder angle (* Measured in thousandths of a °C)

Table IV.5. Post-hoc arm by distance comparisons for temperature slope

Arm	Distance	Mean (°C/s*)	Grouping
Non-dominant	Origin	3.41	A
Dominant	Insertion	3.32	A
Non-dominant	Middle	3.15	A
Non-dominant	Insertion	3.09	A
Dominant	Middle	3.03	A
Dominant	Origin	2.91	A

* Measured in thousandths of a °C

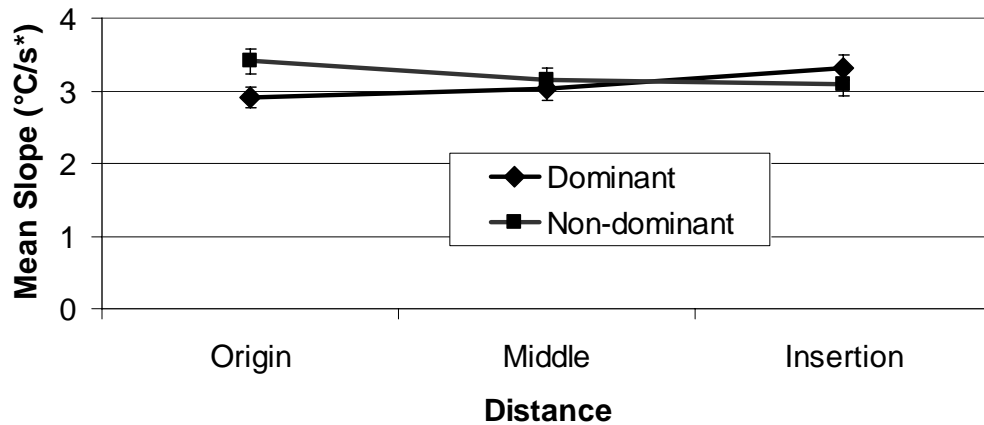

Figure IV.5. Mean temperature slopes for muscle location (distance) by arm (* Measured in thousandths of a °C)

Table IV.6. Post-hoc arm by gender comparisons for mean temperature slope

Condition	Gender	Mean (°C/s*)	Grouping	
Non-dominant	Male	3.61	A	B
Dominant	Female	3.49	A	C
Non-dominant	Female	2.83	B	D
Dominant	Male	2.68	C	D

* Measured in thousandths of a °C

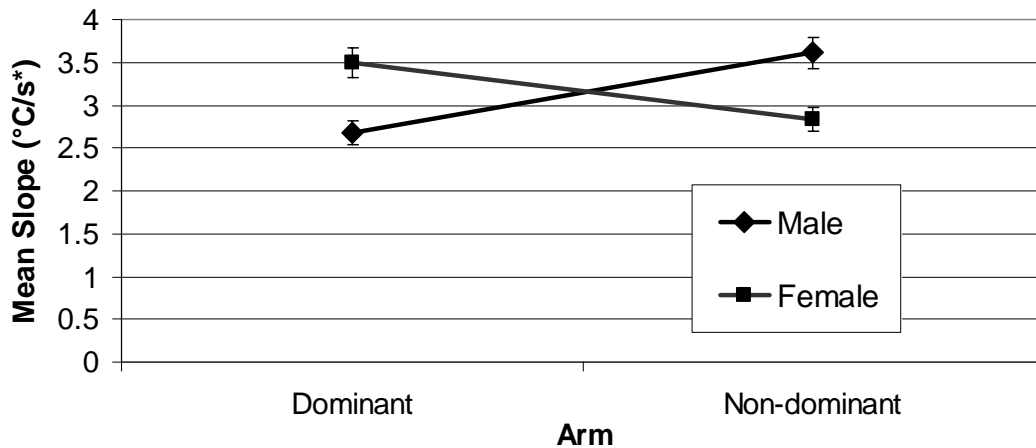

Figure IV.6. Mean temperature slopes for arm by gender interactions (* Measured in thousandths of a °C)

4.4 Modified Borg CR-10 Ratings

The modified Borg CR-10 rating slope estimates of perceived discomfort differed significantly for exertion level ($p < 0.0001$), arm ($p = 0.0446$), and the interaction of shoulder angle by exertion level ($p = 0.0170$) (Table IV.7). Slope was higher for the 30% exertion level (3.26) versus the 15% exertion level (2.05). Discomfort ratings increased significantly faster for participant's dominant arm (slope = 2.78 for the dominant arm and slope = 2.54 for the non-dominant arm). For the shoulder angle by exertion level interaction, conditions containing the higher exertion level (30% MVE) resulted in faster increases in discomfort than conditions containing the lower exertion level (Table IV.8 and Figure IV.7).

Table IV.7. Modified Borg Slope ANOVA for each shoulder angle, exertion level, arm, gender, and their interactions

Variable	P Value
Shoulder	0.3437
Exertion	<.0001
Shoulder * Exertion	0.0170
Arm	0.0446
Shoulder * Arm	0.5749
Exertion * Arm	0.7341
Shoulder * Exertion * Arm	0.2944
Gender	0.0854
Shoulder * Gender	0.5045
Exertion * Gender	0.2704
Shoulder * Exertion * Gender	0.8076
Arm * Gender	0.1535
Shoulder * Arm * Gender	0.5664
Exertion * Arm * Gender	0.9526
Shoulder * Exertion * Arm * Gender	0.6492

Shaded regions are significant ($\alpha = 0.05$)

Table IV.8. Modified Borg Slope for each experimental condition regardless of arm selection or participant

Condition	Mean	Grouping
S2/E2	3.35	A
S1/E2	3.17	A
S1/E1	2.25	B
S2/E1	1.85	B

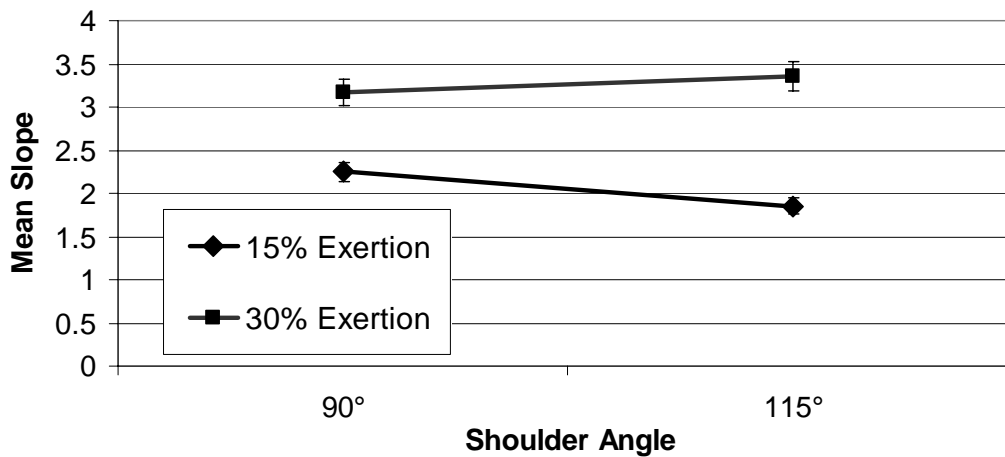

Figure IV.7. Mean modified Borg slopes for shoulder angles

4.5 Correlations

Correlations between thermal readings and Borg rating were not significant. The correlations ($p \leq 0.05$, $|r| \geq 0.25$) between dependant variables demonstrated nothing for simple relationships. When isolating the levels of the dependant variables with the independent variables, no correlations were found (Appendix B, Table B.4.).

4.6 Visual Analogue Discomfort Scale (VADS)

VADS scores were analyzed in terms of percent (i.e., a mark on the 10 cm line 5 cm from the end is equivalent to 50%). There were no reports of body parts discomfort over 49% other than the upper extremity (shoulder, elbow, and hand and wrist). Ratings for the active (tested) side were always higher than the non-active (non-tested) side. Mean and maximum reported values for participants are located in Figure IV.8.

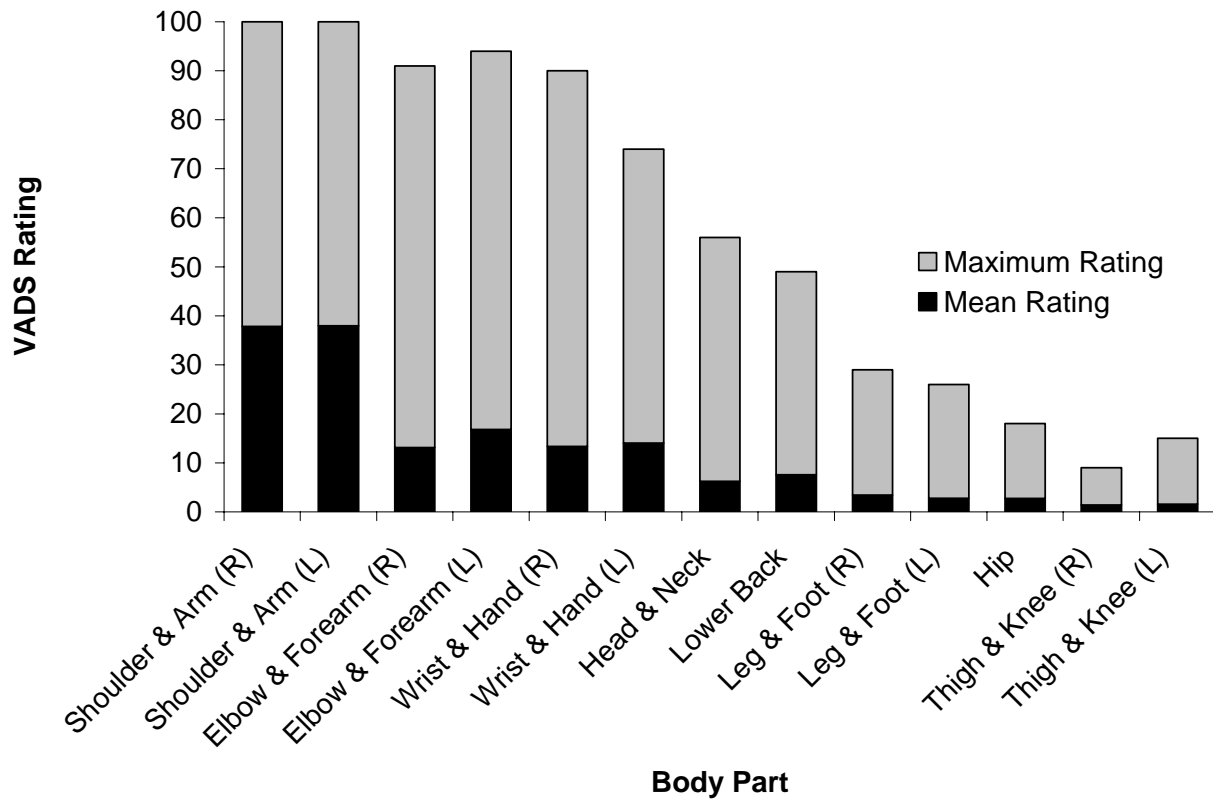

Figure IV.8. Visual Analogue Discomfort Scale mean and maximum reported values for each body part.

CHAPTER V

DISCUSSION AND CONCLUSIONS

5.1 Discussion

The objective of this study was to assess anterior deltoid surface temperature changes as a function of shoulder angle and exertion level during static overhead exertions. In general, the results show that thermal readings were sensitive to changes in work demands. A unique aspect of this study, in terms of shoulder angle effects, is that shoulder moments have not been controlled for in many previous studies. In this study the moment between shoulder angles was controlled for and therefore not different. Since moments were not different between shoulder angles, bias was reduced when comparing the effects of temperature slopes and intercepts, Borg CR-10 rating slopes, and endurance times.

Hypothesis 1: Shoulder angle and exertion level will affect the surface temperature changes over the anterior deltoid.

This hypothesis was partially supported by the study results. Shoulder angle significantly affected surface temperature over the anterior deltoid but exertion level did not. However, non-dominant arm was the main driver since significant differences in the dominant arm for shoulder angles were not found. Higher shoulder angles in the non-dominant arm were found to increase temperature slopes at slower rates than lower angles, possibly due to the increased pressure in the shoulder. Lower temperature slopes present a higher risk of injury due to reduced blood flow to the necessary organs. This finding is in agreement with several earlier researchers which found upper arm elevation angle is the most important factor in determining shoulder load (Sigholm et al., 1984). They found that when raising the upper arm in flexion from 45° to 90°, the RMS values almost doubled. Hagberg's (1984) study in which he found that impaired blood flow was the primary pathophysiological reason for shoulder injuries in overhead work, supports these results as well. Reduced blood flow may have resulted from compression of the humeral head on the tendons and continual tension in the tendons. Anton et al. (2001) found that reducing the upper arm elevation and moving closer to the work vertically may be a viable way of preventing impingement syndromes. Their study evaluated overhead work using a ladder and choosing the correct step for the task. This study controlled for upper arm posture and forced the participants

to work with their upper arms close the body (little lateral deviation). Therefore, the temperature reading changes are likely more a direct result of arm elevation than lateral arm deviation. However, further studies on the effects of lateral upper arm movement on thermal readings are needed to confirm this hypothesis.

Exertion levels, surprisingly, did not have an effect on anterior deltoid thermal readings. It is possible that in only using two exertion levels that were within relatively low exertion ranges, there was not a sufficient enough range see differences. However, as previous literature had indicated that blood flow impairment is present at exertion levels just below 20% MVC (Barcroft and Millen, 1939; Bjelle et al., 1981; Larsson et al., 1990; Reneman et al., 1980) and the levels evaluated (15% and 30% total MVC) spanned this value, changes were expected. Muscle differences may account for the lack of a finding. The above referenced studies investigated larger muscle groups (not the shoulder) when investigating blood flow changes. It is possible that shoulder blood flow is different for reasons of physiological architecture and location in relation to the height of the heart. Therefore it is probable that changes may be seen when comparing lower or higher MVC levels. Also, the results may have been driven by shoulder angle. The effects of shoulder angle on blood flow that changes in exertion level are masked. Further studies are needed to address this hypothesis.

Interesting results were found in arm and shoulder angle interactions for temperature slope. When comparing shoulder angles to arm dominance, slopes increased for the 90° shoulder angle from dominant to non-dominant arm. The opposite was found for the 115° shoulder angle, thus showing that the non-dominant arm was greatly affected by the shoulder angle. A similar result was found when looking at temperature slope differences for muscle distance. Moving from origin to insertion, temperature slopes for the dominant arm increased while slopes for the non-dominant arm decreased. The rationale to this trend is unknown but can be hypothesized to differences in vasculature, strength and muscle fiber composition. Increased vasculature would allow for improved blood flow and it can be hypothesized based on these results that the dominant arm has better vasculature than the non-dominant arm. Muscle fiber types may differ between arms where the non-dominant arm might have more Type I fibers and thus less capillary supply (Lindman et al., 1991).

Gender differences were not expected, however arm effects differed for gender. Males were found to have higher slope values for the dominant arm, while females had higher slope values for their non-dominant arm. The cause or reasoning behind these results are unknown, and represent an area for further research.

Hypothesis 2: Muscle temperature changes will be related to changes in modified Borg CR-10 ratings over time.

No correlation was found between thermal readings and Borg ratings of discomfort. Study limitations (discussed later) may account for the lack of findings. Discomfort ratings may not relate to blood flow requirements of the anterior deltoid because significant effects for modified Borg ratings were found to not be significant for temperature changes. Muscle co-activation might also have an effect on temperature changes which might not correlate to modified Borg ratings. Introducing additional exertion levels or shoulder angles may provide more granularity in the data allowing for trends to become more apparent. Also, sample size may have resulted in this finding. Though efforts were made to ensure the sample size was large enough to detect differences in thermal readings, a lack of existing data made estimation of appropriate sample sizes difficult.

5.2 Conclusions

The findings of this study exhibit that the use of thermography as an analysis tool is viable. Thermal readings were sensitive to changes in work demands. The argument of whether exertion or posture creates a greater risk of injury still needs further analysis, though thermography points towards posture. The results of this study may have been affected by a number of study limitations.

5.2.1 Limitations

Skin surface temperature was evaluated in this study and could have been impacted by blood flow, muscle heating, or other underlying physiological responses to the task. Therefore, using thermography to identify the specific cause of thermal readings is not possible. Outside of physiological effects on the resultant thermal readings, participant factors may have also

influenced the findings. Efforts were taken to select participants that would minimize the influence of potential confounding factors (e.g., body fat, scar tissue, etc.). This implies that the study population was in physically better state than the average population, which in itself may have influenced results. However skin thickness, invisible tissue artifacts, and other physiological biases could have biased the results.

Controlling for posture biases was performed; however the posturing device was not restrictive in all directions. Therefore some movement away from the intended setup occurred, and the only way to prevent this movement it to design the fixture with supports that would immobilize the participant except for movement in the direction of force output.

Calculating percent MVE was determined assuming the posture force was approximately equivalent to the force of the arm. Calculating moments from historical anthropometric data to determine the exact force of the arm was performed to ensure this assumption. The assumption was correct for the 15% and 30% exertion levels with an error less than .2% and 1% respectively. Future studies should use better methods for estimation of the moment of the arm on the shoulder.

Since the task was one that had the participant exert force until exhaustion, motivation and performance could be a bias. The participants were instructed not to quit until they could not generate the force required or they felt pain above their threshold. By monitoring their discomfort ratings, force output, and offering verbal encouragement, biases were, hypothetically, kept to a minimum.

Data collection presented several obstacles since the study was novel and past studies provided minimal assistance. One source of error was the marker, a penny, disappearing in the image during the data collection. A different marker system that does not disappear is needed to distinguish the selected capture area with minimal data loss. Another concern was the room temperature and humidity. The temperature fluctuated from day to day because the room that was used was not an environmental chamber. The humidity was never captured, but could have contributed to some error since humidity can raise or lower the relative temperature. If the participant perspired during the experiment, the surface and/or core temperature could have

contributed to error in the data. The room temperature was kept low to prevent perspiration and the anterior deltoid is not typically an area that perspires.

The camera and software also presented issues. The technology of infrared cameras and their uses are quickly evolving, therefore improvements in accuracy and reliability progress with newer cameras. The camera used in the experiment was one of the leaders in infrared technology at the time of the experiment, but newer technology can improve the results for future studies. The software for the camera was very elementary and therefore it was only used for data collection and screening analysis. The data collected was in a proprietary numeric format for each image collected. To determine the temperature values for the image, a Matlab program was developed to correlate the numeric values with Celsius values so the data could be used, which could have introduced error into the results. The Matlab program also determined the location of the pennies and calculated the desired area for analysis, as this capability was not possible with the camera software. Since there were some lost images (as indicated above due to missing markers), integrity of the sample may have been impacted. As less than 5% of the frames were unusable, it is likely that this was not the case. Also, the use of the generated program developed an analysis grid based on marker size. Changes in participant posture could have impacted the size of the markers creating slightly different grid regions.

5.3 Future Directions

Pioneering research that combines overhead work with a new measurement tool will have limitless possibilities for future research. Using thermography as an analysis tool for tasks that cannot be evaluated via EMG can provide insight in an area that is sometimes limited by invasive analysis procedures. Comparing EMG to thermography may help to bridge gaps in research that are currently unknown. Thermography may also be useful in showing the effects of fatigue and recovery for multiple muscle groups where EMG may have difficulties capturing multiple muscles or connective tissues. Once a level of blood flow impairment is established with thermography, determining standards relating to risk levels could be determined thus providing a metric for comparison. Further research in thermography will add and possibly answer many questions regarding risk factors and their importance in relation to MSDs.

Thermography for this study showed that shoulder angle was a factor in anterior deltoid temperature differences; bringing some insight and more controversy to the debate on posture versus force. The present study only used 10 participants but in using more participants the result may also show that exertion is an important factor in task design. Shoulder heights evaluated in this study can be expanded upon to examine the extent of shoulder height and its effects on work performance and risk relating to MSDs.

Evaluating other muscles or connective tissues is needed to determine if this tool would be effective in ergonomic research. CTS is a prime example of an MSD that that could be evaluated with thermography. This research could provide a link between the current thermography research in CTS and early injury prevention.

The level of exertion used in this study evaluated a level below and above the hypothesized level (20% MVC) where blood flow occlusion starts. Increased and/or decreased levels of exertion might demonstrate a different estimated level of occlusion. It is possible that the levels used in this study were either below or above the level required to occlude blood flow.

Analysis of skin temperature recovery was not performed in this study, but would be a great addition to future work. Recovery times could be used to distinguish differences that may not have been seen during the task. There is extensive research on muscle recovery times and with this a relationship may be drawn via skin surface temperatures. It could be hypothesized that the harder the task the longer it would be for the temperature to reach baseline.

In some industries exertion levels may be a larger factor in overhead work, while working until exhaustion may not. Higher levels of exertion with shorter durations may provide insight into dynamic work analysis. Other dynamic studies could also be performed that may have more significance when compared to Borg CR-10 ratings.

Dominant arm was used in this study to differentiate between arms, however another metric might show more significance. One measure would be arm strength because there might be a difference in muscle fiber types and vasculature. Lindman et al., (1991) provided evidence that myalgic muscles had more Type I fibers as well as a smaller capillary supply than healthy

muscles. This could be evidence that supports why no significance was found for exertion. Measuring the types and quantities of muscle fibers was not performed in this study but could be in future studies.

The sampling rate used in this study was 1 Hz due to computer limitations, though newer technology should allow for a higher sampling rate which will be able to collect smaller temperature changes. Temperature fluctuations over a few seconds produced a temperature plot similar to an electrocardiogram (EKG) thus a reason to collect at a higher sampling rate. Collecting smaller fluctuations may allow for analysis of heart rate rhythms in conjunction with physiological changes during the task. This may be important if looking at how the blood flow affects the muscle origin differently than the insertion. Lastly, if a higher sample rate is used, analyzing different portions of data in time (i.e. beginning, middle, and end) will produce better curve fitting since more data points could be collected.

Using thermography workplace settings could be viable after further research in laboratory settings. Limitations will be present, however determining how much they influence the results must be further studied. With advances in infrared technology, it may be possible to limit biases present in data collection. Some challenges that are present in using thermography outside of the laboratory setting include environmental effects, clothing influences, standardization of measurement location, and participant differences relating to age.

5.4 Summary

Using thermography to assess work demands shows potential beyond its accepted diagnostic capabilities. The findings of this study demonstrate that shoulder angle is a more important factor in work design than exertion level for overhead work. There are a number of extensions of this study that would further evaluate the prognostic or appraising uses. Future research in thermography should help to exhibit validity and reliability making thermography an accepted ergonomic tool.

REFERENCES

- AMA Council on Scientific Affairs. (1987). AMA Council Report: Thermography in neurological and musculoskeletal conditions. *Thermography*, 2, 600-607.
- American College of Sports Medicine. (2000). *ACSM's Guidelines for Exercise Testing and Prescription* (Sixth ed.). Philadelphia: Lippincott, Williams, and Wilkins.
- Anton, D., Shibley, L. D., Fethke, N. B., Hess, J., Cook, T. M., & Rosecrance, J. (2001). The effect of overhead drilling position on shoulder moment and electromyography. *Ergonomics*, 44, 489-501.
- Barcroft, H., & Millen, J. L. E. (1939). The blood flow through muscles during sustained contractions. *Journal of physiology*, 97, 17-31.
- Bengtsson, A., Henriksson, K.-G., & Larsson, J. (1986). Muscle biopsy in primary fibromyalgia. *Scandinavian journal of rheumatology*, 15(1), 1-6.
- Bjelle, A., Hagberg, M., & Michaelsson, G. (1981). Occupational and individual factors in acute shoulder-neck disorders among industrial workers. *British Journal of Industrial Medicine*, 38, 356-363.
- Bureau of Labor Statistics (BLS). (2001). Workplace Injuries and Illnesses in 2000. Retrieved February 5, 2006 from <ftp://ftp.bls.gov/pub/news.release/history/osh.12182001.news>.
- Bureau of Labor Statistics (BLS). (2005). TABLE 11. Percent distribution of nonfatal occupational injuries and illnesses involving days away from work by selected injury or illness characteristics and number of days away from work, 2004. Retrieved February 5, 2006 from <http://www.bls.gov/iif/oshwc/osh/case/osnr0024.pdf>.
- Bureau of Labor Statistics (BLS). (2006a). Case and Demographic Characteristics for Work-related Injuries and Illnesses Involving Days Away From Work. Retrieved February 5, 2006 from <http://www.bls.gov/iif/oshcdnew.htm>.
- Bureau of Labor Statistics (BLS). (2006b). Occupational injuries and illnesses: industry data. Retrieved February 5, 2006 from <http://www.bls.gov/iif/>.
- Borg, G. (1982). A category scale with ratio properties for intermodal and interindividual comparisons. In H. G. Geissler, Petzold, P. (Ed.), *Psychophysical judgement and the process of perception*. VEB Deutscher Verlag der Wissenschaften (pp. 25-34). Berlin.

- Carlson, B. (1969). Level of maximum isometric strength and relative load isometric endurance. *Ergonomics*, *12*, 429-435.
- Chaffin, D. B., Andersson, G. B., & Martin, B. J. (1999). *Occupational Biomechanics* (3rd ed.). New York: John Wiley & Sons, Inc.
- Coury, H. G., Kumar, S., & Narayan, Y. (1998). An electromyographic study of upper limb adduction force with varying shoulder and elbow postures. *Journal of Electromyography and Kinesiology*, *8*, 157-168.
- Elert, J. E., Rantapaa-Dahlqvist, S. B., Henriksson-Larsen, K., Lorentzon, R., & Gerdle, B. (1991). Muscle performance, electromyography and fibre type composition in fibromyalgia and work-related myalgia. *Scandinavian journal of rheumatology*, *21*, 28-34.
- Feldman, F., & Nickoloff, E. (1984). Normal thermographic standards for the cervical spine and upper extremities. *Skeletal Radiology*, *12*, 235-249.
- Frim, J., Livingstone, S. D., Reed, L. D., Nolan, R. W., & Limmer, R. E. (1990). Body composition and skin temperature variation. *Journal of Applied Physiology*, *68*(2), 540-543.
- Gerdle, B., Eriksson, N. E., Brundin, L., & Edstrom, M. (1988). Surface EMG recordings during maximum static shoulder forward flexion in different positions. *European Journal of Applied Physiology and Occupational Physiology*, *57*, 415-419.
- Gershon-Cohen, J., Borden, A., & Hermel, M. (1969). Thermography of the extremities after smoking. *British Journal of Radiology*, *42*, 189.
- Gray, H. (1995). *Anatomy; Descriptive and Surgical* (Fifteenth ed.). New York: Barnes & Noble Books.
- Green, J. (1987). Neurothermography. *Seminars in Neurology*, *7*(4), 313-316.
- Hagberg, M. (1981). Electromyographic signs of shoulder muscular fatigue in two elevated arm positions. *American Journal of Industrial Medicine*, *60*(3), 111-121.
- Hagberg, M. (1982). Local shoulder muscular strain - symptoms and disorders. *Journal of Human Ergology*, *11*, 99-108.
- Hagberg, M. (1984). Occupational musculoskeletal stress and disorders of the neck and shoulder: a review of possible pathophysiology. *Int Arch Occup Environ Health*, *53*, 269-278.

- Hagberg, M. (1992). Exposure variables in ergonomic epidemiology. *American Journal of Industrial Medicine*, 21, 91-100.
- Hagberg, M., & Wegman, D. H. (1987). Prevalence rates and odds ratios of shoulder-neck diseases in different occupational groups. *British Journal of Industrial Medicine*, 44, 602-610.
- Hagg, G. (1991). Static work loads and occupational myalgia - a new explanation model. In P. A. Anderson & D. J. Hobart & J. V. Danoff (Eds.), *Electromyographical Kinesiology: Proceedings of the 8th Congress of the International Society of Electrophysiological Kinesiology, Held in Baltimore* (pp. 141-143). Amsterdam: Elsevier.
- Harway, R. A. (1986). Precision thermal imaging of the extremities. *Orthopedics*, 9(3), 379-382.
- Haslegrave, C., Tracy, M., & Corlett, E. (1997). Force exertions in awkward postures - strength capability while twisting or working overhead. *Ergonomics*, 40(12), 1335-1362.
- Herberts, P., & Kadefors, R. (1976). A Study of Painful Shoulder in Welders. *Acta Orthopaedica Scandinavica*, 47, 381-387.
- Herberts, P., Kadefors, R., Hogfors, C., & Sigholm, G. (1984). Shoulder pain and heavy manual labor. *Clinical orthopaedics and related research*, 191, 166-178.
- Herrick, R., & Herrick, S. (1987). Thermography in the detection of carpal tunnel syndrome and other compressive neuropathies. *The Journal of Hand Surgery*, 12A(5), 943-949.
- Hobbins, W. (1982). Thermography and Pain. *Progress in Clinical and Biological Research*, 107, 361-375.
- Holmstrom, E., Lindell, J., & Moritz, U. (1992). Low back and neck/shoulder pain in construction workers: occupational workload and psychosocial risk factors. *Spine*, 17, 672-677.
- Hubbard, J. E., & Hoyt, C. (1985). Pain evaluation by electronic infrared thermography: Correlations with symptoms, EMG, myelogram and CT scan. *Thermology*, 1, 26-35.
- Humphreys, P. W., & Lind, A. R. (1963). The blood flow through active and inactive muscles of the forearm during sustained handgrip contractions. *Journal of physiology*, 166, 120-135.
- Iversen, P. O., Standa, M., & Nikolaysen, G. (1989). Marked regional heterogeneity in blood flow within a single skeletal muscle at rest and during exercise hyperaemia. *Acta physiologica Scandinavica*, 136, 17-28.

- Jarvoholm, U., Palmerud, G., Karlsson, D., Herberts, P., & Kadefors, R. (1991). Intramuscular pressure and electromyography in four shoulder muscles. *Journal of Orthopaedic Research*, 9, 609-619.
- Jeracitano, D., Cooper, R., Lyon, L., & Jayson, I. (1992). Abnormal temperature control suggesting sympathetic dysfunction in the shoulder skin of patients with frozen shoulder. *British Journal of Rheumatology*, 31, 539-542.
- Kadefors, R., Petersen, I., & Herberts, P. (1976). Muscular reaction to welding work: and electromyographic investigation. *Ergonomics*, 19, 543-558.
- Karwowski, W., & Marras, W. (Eds.). (1999). *The Occupational Ergonomics Handbook*. New York: CRC Press.
- Kilbom, A. (1988). Isometric strength and occupational muscle disorders. *European Journal of Applied Physiology*, 57, 322-326.
- Kroemer, K. H. E., Kroemer, H. B., & Kroemer-Elbert, K. E. (1994). *Ergonomics*. Englewood Cliffs, NJ: Prentice Hall.
- Larsson, S. E., Bodegard, L., Henriksson, K.-G., & Oberg, A. (1990). Chronic trapezius myalgia: Morphology and blood flow studies in 17 patients. *Acta orthopaedica Scandinavica*, 61, 394-398.
- Larsson, S. E., Larsson, R., Zhang, Q., Cai, H., & Oberg, A. (1995). Effects of psychophysiological stress on trapezius muscles blood flow and electromyography during static load. *European Journal of Applied Physiology*, 71, 493-498.
- Lind, A. R., & McNicol, G. W. (1967). Local and central circulatory responses to sustained contractions and the effect of free or restricted arterial inflow on post-exercise hyperemia. *Journal of physiology*, 192, 575-593.
- Lindman, R., Hagberg, M., Angqvist, K.-A., Soderlund, K., Hultman, E., & Thornell, L.-E. (1991). Changes in muscle morphology in chronic trapezius myalgia. *Scandinavian Journal of Work, Environment & Health*, 17, 347-355.
- Markhede, G., Monastyrski, J., & Stener, B. (1985). Shoulder function after deltoid muscle removal. *Acta Orthopaedica Scandinavica*, 56(3), 242-244.
- Milerad, E., & Ericson, M. O. (1994). Effects of precision and force demands, grip diameter, and arm support during manual work: and electromyographic study. *Ergonomics*, 37(2), 255-264.

- Miyakoshi, N., Itoi, E. S., K., Suzuki, K., & Matsuura, H. (1998). Skin temperature of the shoulder: circadian rhythms in normal and pathologic shoulders. *Journal of Shoulder and Elbow Surgery / American Shoulder and Elbow Surgeons ... [et al.]*, 7(6), 625-628.
- Nieminen, H., Takala, E.-P., Niemi, J., & Viikari-Juntura, E. (1995). Muscular synergy in the shoulder during a fatiguing static contraction. *Clinical Biomechanics*, 10(6), 309-317.
- National Institute for Occupational Safety and Health (NIOSH). (11-22-1997). *Musculoskeletal Disorders (MSDs) and Workplace Factors: Chapter 3. Shoulder Musculoskeletal Disorders: Evidence for Work-Relatedness*. Retrieved February 5, 2006 from <http://www.cdc.gov/niosh/ergtxt3.html>.
- Nussbaum, M., Clark, L. L., Lanza, M. A., & Rice, K. M. (2001). Fatigue and endurance limits during intermittent overhead work. *AIHAJ*, 62, 446-456.
- Oerlemans, M., Graff, M., Dijkstra-Hekkink, J., Boo, T., Goris, J., & Oostendrop, R. (1999). Reliability and normal values for measuring the skin temperature of the hand with infrared tympanic thermometer: a pilot study. *Journal of Hand Therapy*, Oct-Dec, 284-290.
- Olson, P. (1987). *Working postures related to musculoskeletal disorders*. Paper presented at the Abstract and poster presented at the XXII International Congress on Occupational Health, Sydney, Australia.
- Petrofsky, J. S., & Lind, A. R. (1975). The relationship of body fat content to deep muscle temperature and isometric endurance in man. *Clinical science and molecular medicine*, 48, 405-412.
- Petrofsky, J. S., LeDonne, D. M., Rinehart, J. S., & Lind, A. R. (1976). Isometric strength and endurance during the menstrual cycle. *European journal of applied physiology*, 35, 1-10.
- Pogrel, A., McNeill, C., & Kim, J. (1996). The assessment of trapezius muscle symptoms of patients with temporomandibular disorders by the use of liquid crystal thermography. *Oral Surg Oral Med, Oral Pathol Oral Radiol Endod.* 82, 145-151.
- Reneman, R. S., Slaff, D. W., Lindholm, L., Targelder, G. J., & Arfors, K. E. (1980). Muscle blood flow disturbances produced by simultaneous elevated venous and total muscle tissue pressure. *Microvascular research*, 20, 307-318.
- Roman-Liu, D., Tokarski, T., & Kaminska, J. (2001). Assessment of the musculoskeletal load of the trapezius and the deltoid muscles during hand activity. *International Journal of*

- Occupational Safety and Ergonomics*, 7(2), 197-193.
- Royce, J. (1958). Isometric curves in human muscle with normal and occluded circulation. *Research Quarterly*, 29, 204-212.
- Ruser, John W. (1999). Lost-Workday Injuries: The changing composition of lost-workday injuries. [Electronic version]. *Monthly Labor Review*, June, 11-13.
- Sakakibara, H., Miyao, M., Kondo, T., & Yamada, S. (1995). Overhead work and shoulder-neck pain in orchard farmers harvesting pears and apples. *Ergonomics*, 38(4), 700-706.
- Sherman, R., Barja, R., & Bruno, G. (1997). Thermographic correlates of chronic pain: analysis of 125 patients incorporating evaluations by a blind panel. *Archives of Physical Medical Rehabilitation*, 68, 273-279.
- Sigholm, G., Herberts, P., Almstrom, C., & Kadefors, R. (1984). Electromyographic analysis of shoulder muscle load. *Journal of Orthopaedic Research*, 1(4), 379-386.
- Sjogaard, G., Kiens, B., Jorgensen, K., & Saltin, B. (1986). Intramuscular pressure, EMG blood flow during low-level prolonged static contraction in man. *Acta Physiol Scand*, 128, 475-484.
- Sommerich, C., McGlothlin, J., & Marras, W. (1993). Occupational risk factors associated with soft tissue disorders of the shoulder: a review of recent investigations in literature. *Ergonomics*, 36, 697-717.
- Sporrong, H., Palmerud, G., & Herberts, P. (1995). Influences of handgrip on shoulder muscle activity. *European Journal of Applied Physiology and Occupational Physiology*, 71(6), 485-492.
- Start, K. B., & Holmes, R. (1963). Local muscle endurance with open and occluded intramuscular circulation. *The Journal of physiology*, 18, 804-807.
- Tanita Corporation. (2001). *TBF-612 Body Fat Monitor / Scale: Instruction Manual*. Tokyo, Japan: Tanita Corporation.
- Tchou, S., Costich, J., Burgess, R., & Wexler, C. (1992). Thermographic observations in unilateral carpal tunnel syndrome: report of 61 cases. *The Journal of Hand Surgery*, 17A(4), 631-637.
- Tsuchida, Y. (1990). Age-related changes in skin blood flow at four anatomic sites of the body in males studied by xenon-133. *Plastic and Reconstructive Surgery*, 85(4), 556-561.

- Uematsu, S., & Long, D. (1976). Thermography in chronic pain. In S. Uematsu (Ed.), *Medical thermography theory and clinical applications* (pp. 52-67). Los Angeles: Brentwood Publishing Corp.
- Uematsu, S., Hendler N., Hungerford, D., Long, D., & Ono, N. (1981). Thermography and electromyography in the differential diagnosis of chronic pain syndromes and reflex sympathetic dystrophy. *Electromyography and Clinical Neurophysiology*, 21, 165-182.
- Visser, J. L., & Straker, L. M. (1994). An investigation of discomfort experienced by dental therapists and assistants at work. *Australian Dental Journal*, 39(1), 39-44.
- Webb Associates (Ed.). (1978). *Anthropometric Source Book Volume II: a handbook of anthropometric data*. Yellow Springs, Ohio: Scientific and Information Office.
- Zhang, H., Kim, Y., & Cho, Y. (1999). Thermatomal changes in cervical disc herniations. *Yonsei Medical Journal*, 40(5), 401-412.

APPENDIX A

Form 1: Participant Data

Participant Number _____

Screening Date _____ Starting Time _____ Ending Time _____

Session 1 Date _____ Starting Time _____ Ending Time _____

Session 2 Date _____ Starting Time _____ Ending Time _____

Session 3 Date _____ Starting Time _____ Ending Time _____

Session 4 Date _____ Starting Time _____ Ending Time _____

Age _____

Gender Male Female **Dominant Hand** Right Left

Ethnicity Caucasian African American Asians/Pacific Islander

Native American Hispanic Other: _____

Form 2: Demographics and Musculoskeletal Data

Demographics

1. Present Occupation (Part/Full time, Starting Date) _____
2. Description of Occupation _____
3. How many hours per week? _____
4. Previous Occupation (Part/Full time, Starting Date) _____
5. Have you had a significant injury to any body part other than the shoulder? If yes, explain.

6. Have you had a significant injury to the shoulder area (Dislocation, separation, fracture, tendonitis, rotator cuff tear, impingement syndrome, etc.)? If yes, explain.

Have you had Pain, Ache, Discomfort, Injuries in:	Yes / No	In the past 12 months		In the last 7 days	
		When did it occur	Duration It lasted	When did it occur	Duration It lasted
Neck					
Shoulders					
Arms / Elbows / Wrist / Hands					
Upper Back / Lower Back					
Knees / Legs					
Hips / Thighs					
Knees / Ankles / Feet					

7. How would you describe your general fitness level?
 Minimal Moderate Average Above Average Maximal
8. How many hours a week do you work out? _____ How long have you been on this workout schedule?

Any Other Comments: _____

Form 3: Anthropometric and Workstation Data

A. Anthropometrics

Weight _____ kg

Stature _____ cm Stature (with shoes) _____ cm

Acromion Height (R/L) _____ / _____ cm

Upper Arm Length (R/L) _____ / _____ cm

Lower Arm Length (R/L) _____ / _____ cm

Hand Length (R/L) _____ / _____ cm

Acromion to acromion distance _____ cm

Feet Breadth _____ cm Foot Offset _____ cm

Visible Marks in Shoulder Area _____

BIA = _____ % Fat

Percentile	Males	Females
50	15.9	22.1

B. Workstation data

Workstation Feet Placement

Posture Control Height and Distance

Feet Placement = _____ cm

Height = _____ cm

Distance (from table) = _____ cm

Shoulder and Elbow Angles

Session = _____ S1 = 90 ° Elbow1 = 115 ° Exertion = 15 % MVC

Session = _____ S2 = 115 ° Elbow2 = _____ ° Exertion = 15 % MVC

Session = _____ S1 = 90 ° Elbow1 = 115 ° Exertion = 30 % MVC

Session = _____ S2 = 115 ° Elbow2 = _____ ° Exertion = 30 % MVC

Form 4: Experiment Data Sheet

A. Arm Load

Trials	Right	Left
T1		
T2		
T3		

Right Average: _____ Left Average: _____

B. MVE'S per Trial

Trials	Right	Left
T1		
T2		
T3		
T4		
T5		
T6		
T7		

Number of Full Trials Completed: _____ **Stopped During Trial Number:** _____

Comments/Unusual Circumstances -

Room temperature (°C): _____ Arm Order: R/L L/R

Session # _____

Form 5: Apparatus Heights and Visual Numerical Discomfort Scale

A. Apparatus Height

	Apparatus Measurement		Work Location Measurement	
Measurement	Pre-Calculated	Actual	Pre-Calculated	Actual
Set Height (Right)				
Set Height (Left)				
Set Distance (Right)				
Set Distance (Left)				

B. Participant Ratings – Right Arm

Time	Rating	Time	Rating
:00		4:00	
:30		4:30	
1:00		5:00	
1:30		5:30	
2:00		6:00	
2:30		6:30	
3:00		7:00	
3:30		7:30	

C. Participant Ratings – Left Arm

Time	Rating	Time	Rating
:00		4:00	
:30		4:30	
1:00		5:00	
1:30		5:30	
2:00		6:00	
2:30		6:30	
3:00		7:00	
3:30		7:30	

D. Resting muscle temperature (Center belly rectangle area _____)

Arm	Min	Mean	Max	Variance
R				
L				
R Before 2 nd Part				
L Before 2 nd Part				

Session # _____

Form 6: Visual Analogue Discomfort Scale

If you have any discomfort, mark on a line the amount of discomfort you feel for each body part which presently feels discomfort.

Left

Right

The diagram shows a human silhouette with 12 body parts labeled. Each label has a dotted line pointing to the corresponding body part. To the left and right of the silhouette are horizontal lines representing a scale from 'no discomfort' to 'extreme discomfort' for each body part.

Body Part	Left Scale	Right Scale
Head & Neck	no discomfort extreme discomfort	no discomfort extreme discomfort
Shoulder & Arm	no discomfort extreme discomfort	no discomfort extreme discomfort
Elbow & Forearm	no discomfort extreme discomfort	no discomfort extreme discomfort
Hip	no discomfort extreme discomfort	no discomfort extreme discomfort
Wrist & Hand	no discomfort extreme discomfort	no discomfort extreme discomfort
Thigh & Knee	no discomfort extreme discomfort	no discomfort extreme discomfort
Leg & Foot	no discomfort extreme discomfort	no discomfort extreme discomfort

Subject: _____ Condition: _____

Form 7: Subjective Rating of Perceived Discomfort (RPD) – Borg CR-10

- 0 None at all
- 0.5 Very, very low discomfort (just noticeable)
- 1 Very low discomfort
- 2 Low discomfort
- 3 Moderate discomfort
- 4 Somewhat high discomfort
- 5 High discomfort
- 6
- 7 Very high discomfort
- 8
- 9
- 10 Very, very high discomfort (almost max)

Table A.1. The presentation order; balanced with repeated Latin squares.
 S = Shoulder Angle E = Exertion Level

Participant	Sex	S1 / E1	S2 / E1	S1 / E2	S2 / E2
1	Male	1 (L/R)	2 (L/R)	4 (L/R)	3 (R/L)
2	Male	2 (R/L)	3 (R/L)	1 (L/R)	4 (L/R)
3	Male	3 (R/L)	4 (L/R)	2 (L/R)	1 (L/R)
4	Male	4 (R/L)	1(L/R)	3 (L/R)	2 (L/R)
5	Male	1 (R/L)	2 (R/L)	4 (L/R)	3 (L/R)
6	Female	1 (R/L)	2 (R/L)	4 (R/L)	3 (L/R)
7	Female	2 (R/L)	3 (L/R)	1 (L/R)	4 (L/R)
8	Female	3 (L/R)	4 (L/R)	2 (R/L)	1 (R/L)
9	Female	4 (L/R)	1 (L/R)	3 (L/R)	2 (R/L)
10	Female	1 (R/L)	2 (R/L)	4 (R/L)	3 (L/R)

APPENDIX B

Table B.1. Participant demographic, fitness level, and past injury data

	1	2	3	4
Demographics				
Age	19	21	19	19
Gender	M	M	M	M
Ethnicity	Caucasian	Asian/Pacific Islander	Caucasian	Indian
Dominant Hand	Left	Right	Left	Right
Current Occupation	Student	McDonalds Crew Trainer	Student	Student
Work Hours Per Week	N/A	20	N/A	N/A
Previous Occupation	Temp Work-Manual Labor - Summer	N/A	Painter-6/03-8/03	N/A
Fitness Level				
	Average	Average	Maximal	Average
Exercise Hours Per Week	3	0	2	5
Exercise Schedule Duration	3 Weeks	0	2-3 Yrs	1 Month
Exercise Activities	Weights and Cardio	Used to run 30 min a day	Weights, cardio	Weights, cardio
Past Injuries (Type, Date, Duration)				
Significant Injuries (other than shoulder)	N/A		N/A	Broken Nose (02)
Neck	N/A	N/A	Soreness on Job (6/03- 8/03)	N/A
Arms, Elbows, Wrist, Hands	N/A	N/A	Fractured Lower Right Arm (95)	N/A
Upper and Lower Back	N/A	N/A	N/A	N/A
Knees, Legs	N/A	N/A	Shin Splints - 3/03	N/A
Hips, Thighs	N/A	N/A	N/A	N/A
Ankle, Feet	N/A	N/A	N/A	N/A
Significant Injuries (shoulder)	N/A	N/A	N/A	N/A

Table B.1. (Continued) Participant demographic, fitness level, and past injury data

	5	6	7	8
Demographics				
Age	21	19	24	20
Gender	M	F	F	F
Ethnicity	Caucasian	Caucasian	Caribbean	Caucasian
Dominant Hand	Right	Right	Right	Right
Current Occupation	Full-time Student/National Guard	Full-time Student	Full-time Student - Cardiac Rehabilitation with patients	Art Gallery Assistant
Work Hours Per Week	N/A	N/A	8 to 9	8
Previous Occupation	N/A	Part time Waitress	Student	N/A
Fitness Level				
	Above Average	Average	Above Average	Above Average
Exercise Hours Per Week	3	0	3 to 5	6
Exercise Schedule Duration	4 Years	0	3 yrs	3 Years
Exercise Activities	Running	Walking	Running	Ballet, aerobic
Past Injuries (Type, Date, Duration)				
Significant Injuries (other than shoulder)	N/A	N/A	N/A	N/A
Neck	N/A	N/A	N/A	N/A
Arms, Elbows, Wrist, Hands	N/A	N/A	N/A	N/A
Upper and Lower Back	N/A	N/A	N/A	N/A
Knees, Legs	N/A	N/A	N/A	N/A
Hips, Thighs	N/A	N/A	N/A	N/A
Ankle, Feet	N/A	N/A	N/A	N/A
Significant Injuries (shoulder)	N/A	N/A	N/A	N/A

Table B.1. (Continued) Participant demographic, fitness level, and past injury data

	9	10
Demographics		
Age	23	20
Gender	F	F
Ethnicity	African American	Caucasian
Dominant Hand	Right	Right
Current Occupation	Full-time Student	Full-time Student
Work Hours Per Week		
Previous Occupation		
Fitness Level		
	Moderate	Maximal
Exercise Hours Per Week	3	14
Exercise Schedule Duration	4 Months	6 Years
Exercise Activities	Swimming	Swimming
Past Injuries (Type, Date, Duration)		
Significant Injuries (other than shoulder)	N/A	N/A
Neck	N/A	N/A
Arms, Elbows, Wrist, Hands	N/A	N/A
Upper and Lower Back	N/A	N/A
Knees, Legs	Injury Unspecified	N/A
Hips, Thighs	N/A	N/A
Ankle, Feet	N/A	Broken Bone in Foot
Significant Injuries (shoulder)	N/A	N/A

Table B.2. Participant anthropometrics and work distances

	1	2
Anthropometrics		
Weight (kg)	68.5	59.2
Stature (m)	1.785	1.657
Stature (m, with shoes)	1.826	1.684
Body Fat Percent	14.7	13.7
Visible Marks on Anterior Deltoid	No	No
Acromion Height (R) (m)	1.503	1.393
Acromion Height (L) (m)	1.494	1.388
Upper Arm Length (R) (m)	0.312	0.292
Upper Arm Length (L) (m)	0.313	0.283
Lower Arm Length (R) (m)	0.285	0.255
Lower Arm Length (L) (m)	0.29	0.252
Hand Length (R) (m)	0.176	0.179
Hand Length (L) (m)	0.18	0.179
Acromion to Acromion Distance (m)	0.343	0.326
Feet Breadth (m)	0.24	0.19
Foot Offset (m)	0.05	0.07
Work Location (m)		
Shoulder 1 (Height) (R)	1.853	1.714
Shoulder 2 (Height) (R)	1.985	1.837
Shoulder 1 (Distance) (R)	0.312	0.292
Shoulder 2 (Distance) (R)	0.283	0.265
Shoulder 1 (Height) (L)	1.850	1.706
Shoulder 2 (Height) (L)	1.982	1.825
Shoulder 1 (Distance) (L)	0.313	0.283
Shoulder 2 (Distance) (L)	0.284	0.256

Table B.2. (Continued) Participant anthropometrics and work distances

	3	4
Anthropometrics		
Weight (kg)	69	60.2
Stature (m)	1.792	1.68
Stature (m, with shoes)	1.818	1.712
Body Fat Percent	12.7	14.3
Visible Marks on Anterior Deltoid	No	No
Acromion Height (R) (m)	1.49	1.43
Acromion Height (L) (m)	1.505	1.42
Upper Arm Length (R) (m)	0.327	0.31
Upper Arm Length (L) (m)	0.32	0.305
Lower Arm Length (R) (m)	0.267	0.258
Lower Arm Length (L) (m)	0.278	0.269
Hand Length (R) (m)	0.182	0.177
Hand Length (L) (m)	0.188	0.181
Acromion to Acromion Distance (m)	0.36	0.341
Feet Breadth (m)	0.27	0.22
Foot Offset (m)	0.04	0.06
Work Location (m)		
Shoulder 1 (Height) (R)	1.823	1.753
Shoulder 2 (Height) (R)	1.962	1.884
Shoulder 1 (Distance) (R)	0.327	0.310
Shoulder 2 (Distance) (R)	0.296	0.281
Shoulder 1 (Height) (L)	1.851	1.755
Shoulder 2 (Height) (L)	1.987	1.884
Shoulder 1 (Distance) (L)	0.320	0.305
Shoulder 2 (Distance) (L)	0.290	0.276

Table B.2. (Continued) Participant anthropometrics and work distances

	5	6
Anthropometrics		
Weight (kg)	65.5	46.9
Stature (m)	181.5	1.726
Stature (m, with shoes)	184.6	1.75
Body Fat Percent	9.4	16.4
Visible Marks on Anterior Deltoid	No	No
Acromion Height (R) (m)	151	1.451
Acromion Height (L) (m)	152	1.469
Upper Arm Length (R) (m)	0.315	0.316
Upper Arm Length (L) (m)	0.321	0.31
Lower Arm Length (R) (m)	0.28	0.286
Lower Arm Length (L) (m)	0.285	0.293
Hand Length (R) (m)	0.182	0.169
Hand Length (L) (m)	0.181	0.168
Acromion to Acromion Distance (m)	0.382	0.331
Feet Breadth (m)	0.29	0.26
Foot Offset (m)	0.05	0.03
Work Location (m)		
Shoulder 1 (Height) (R)	1.799	1.694
Shoulder 2 (Height) (R)	1.932	1.820
Shoulder 1 (Distance) (R)	0.316	0.298
Shoulder 2 (Distance) (R)	0.286	0.270
Shoulder 1 (Height) (L)	1.824	1.663
Shoulder 2 (Height) (L)	1.955	1.791
Shoulder 1 (Distance) (L)	0.310	0.302
Shoulder 2 (Distance) (L)	0.281	0.274

Table B.2. (Continued) Participant anthropometrics and work distances

	7	8
Anthropometrics		
Weight (kg)	50.1	55.3
Stature (m)	1.587	1.597
Stature (m, with shoes)	1.615	1.637
Body Fat Percent	21.3	18.3
Visible Marks on Anterior Deltoid	No	No
Acromion Height (R) (m)	1.357	1.34
Acromion Height (L) (m)	1.332	1.335
Upper Arm Length (R) (m)	0.298	0.287
Upper Arm Length (L) (m)	0.302	0.286
Lower Arm Length (R) (m)	0.275	0.257
Lower Arm Length (L) (m)	0.268	0.256
Hand Length (R) (m)	0.171	0.178
Hand Length (L) (m)	0.177	0.167
Acromion to Acromion Distance (m)	0.296	0.327
Feet Breadth (m)	0.21	0.31
Foot Offset (m)	0.04	0.01
Work Location (m)		
Shoulder 1 (Height) (R)	1.661	1.694
Shoulder 2 (Height) (R)	1.782	1.810
Shoulder 1 (Distance) (R)	0.287	0.275
Shoulder 2 (Distance) (R)	0.260	0.249
Shoulder 1 (Height) (L)	1.653	1.710
Shoulder 2 (Height) (L)	1.773	1.828
Shoulder 1 (Distance) (L)	0.286	0.278
Shoulder 2 (Distance) (L)	0.259	0.252

Table B.2. (Continued) Participant anthropometrics and work distances

	9	10
Anthropometrics		
Weight (kg)	48.7	66.6
Stature (m)	1.642	1.655
Stature (m, with shoes)	1.665	1.663
Body Fat Percent	19.6	17.6
Visible Marks on Anterior Deltoid	No	No
Acromion Height (R) (m)	1.378	1.368
Acromion Height (L) (m)	1.381	1.36
Upper Arm Length (R) (m)	0.275	0.292
Upper Arm Length (L) (m)	0.278	0.285
Lower Arm Length (R) (m)	0.254	0.259
Lower Arm Length (L) (m)	0.266	0.259
Hand Length (R) (m)	0.168	0.169
Hand Length (L) (m)	0.176	0.175
Acromion to Acromion Distance (m)	0.325	0.331
Feet Breadth (m)	0.23	0.24
Foot Offset (m)	0.05	0.04
Work Location (m)		
Shoulder 1 (Height) (R)	1.856	1.689
Shoulder 2 (Height) (R)	1.990	1.812
Shoulder 1 (Distance) (R)	0.315	0.292
Shoulder 2 (Distance) (R)	0.285	0.265
Shoulder 1 (Height) (L)	1.871	1.682
Shoulder 2 (Height) (L)	2.007	1.802
Shoulder 1 (Distance) (L)	0.321	0.285
Shoulder 2 (Distance) (L)	0.291	0.258

Table B.3. Temperature slope ANOVA for each shoulder angle, exertion level, arm, distance, position, time, and their interactions

Effect	P Value
Shoulder	0.0041
Exertion	0.1562
Shoulder x Exertion	0.5523
Arm	0.2760
Shoulder x Arm	0.0021
Exertion x Arm	0.1781
Shoulder x Exertion x Arm	0.5822
Distance	0.7265
Shoulder x Distance	0.1700
Exertion x Distance	0.8652
Should x Exertion x Distance	0.6056
Arm x Distance	0.0493
Shoulder x Arm x Distance	0.5175
Exertion x Arm x Distance	0.8686
Position	0.2435
Shoulder x Position	0.5317
Exertion x Position	0.9766
Should x Exertion x Position	0.9589
Arm x Position	0.5718
Shoulder x Arm x Position	0.5828
Exertion x Arm x Position	0.5486
Distance x Position	0.9873
Should x Distance x Position	0.9992
Exertion x Distance x Position	0.9496
Arm x Distance x Position	0.9344
Gender	0.9958
Shoulder x Gender	0.2159
Exertion x Gender	0.3432
Should x Exertion x Gender	0.2079
Arm x Gender	<.0001
Shoulder x Arm x Gender	0.8831
Exertion x Arm x Gender	0.2476
Distance x Gender	0.1485
Should x Distance x Gender	0.0655
Exertion x Distance x Gender	0.9018
Arm x Distance x Gender	0.0637
Position x Gender	0.5226
Should x Position x Gender	0.5371
Exertion x Position x Gender	0.8112
Arm x Position x Gender	0.7013
Distance x Position x Gender	0.8973
Body Fat	0.9002
Room Temp	0.0040
Core Temp	0.0013

Table B.4. Correlations for temperature slope

Variable	rho (p)
Borg Ratings	-0.08949 (0.0501)
Moment	0.06816 (0.1359)
Endurance Time	0.01175 (0.7974)

VITA

Ian Bertmaring graduated from Virginia Tech with a B.S. in Industrial and Systems Engineering in 2001, and from Virginia Tech with a M.S. in Industrial and Systems Engineering in 2006 with a focus in Human Factors Engineering and Ergonomics. While at Virginia Tech, he served as a teaching assistant and was awarded a National Institute for Occupational and Safety Health (NIOSH) Fellowship for 2001 and 2002. Ian currently works as an Ergonomist for the University of North Carolina at Chapel Hill.