

**Fish ecomorphology: predicting habitat preferences of
stream fishes from their body shape.**

Matthew D. Chan

Dissertation submitted to the Faculty of the
Virginia Polytechnic Institute and State University
in partial fulfillment of the requirements for the degree of

DOCTOR OF PHILOSOPHY

in

Fisheries and Wildlife Sciences

Donald J. Orth, Chairman

Paul L. Angermeier

John J. Ney

Eric P. Smith

Panayiotis Diplas

24 May 2001

Blacksburg, Virginia 24061-0321

Key Words: ecomorphology, habitat guilds, instream flow, swimming performance,
habitat use, surrogate species, phylogenetic, discriminant analysis, morphometrics,
stream fishes

Copyright 2001, Matthew D. Chan

Fish ecomorphology: predicting habitat preferences of stream fishes from their body shape.

Matthew D. Chan

(ABSTRACT)

This research tested the ability of fish morphology to predict membership of fishes in habitat guilds, their swimming performance, and habitat preference. Further, it considered methods for choosing a surrogate species to identify habitat of target species. Morphological discriminant functions were developed using morphological traits of fishes from one river to identify membership in two habitat guild systems (mesohabitat and microhabitat). Functions were then used to test factors influencing classification success of holdout tests and validated using fishes of a second river. Morphology was only partly successful (50%) at predicting membership in habitat guilds. Morphology identified species by shape, i.e., classifying test species into guilds with members of their genus, but not habitat use, because morphology and habitat were not strongly linked through function. By improving guild definition, relationships between morphology and habitat (Froude number) were identified for all fish groups examined (darters, benthic minnows, pelagic minnows, and suckers). Relationships were not transferable among groups. Further, morphology of eight minnows was linked to swimming performance, a key task for using habitat, in lab measurements of critical swimming speeds. In turn, swimming performance was related to habitat (Froude number). Morphology will be most successful at predicting habitat use of fishes when (1) more, discrete guilds are used, (2) guilds are identified within families, (3) variation in lifestyles (benthic vs. pelagic) is considered, and (4) key tasks related to using habitat are strongly associated with morphology. Finally, I examined a phylogenetic approach to identifying useable habitat. Closely related surrogate species were not more accurate in identifying habitat of target species than surrogates chosen by other methods. When a target species used only one mesohabitat, the highest overlap in habitat use occurred with other fishes of the same family using that mesohabitat (within a physiographic province). For target species using several mesohabitat types, surrogates from the next highest taxonomic unit, e.g., genus or subgenus, provided the most accurate information. Ecomorphology offers a mechanistic and defensible method for

identifying habitat preferences of fishes and should be more widely considered as a tool for establishing habitat relationships of stream fishes.

Acknowledgments

This dissertation research spanning almost five years was successfully completed because of the support of numerous individuals. I acknowledge my father and mother (P. A. Chan, Jr., and C. L. Chan), my sisters (A. L. Chan, A. E. Chan), my aunt and cousin (M. A. Walker, C. Irwin), extended family member M. Mikstay, and my grandmother (A. E. Stark, or “Nanny”) for supporting my educational climb. Special thanks to my dog, Sam, for his companionship, and, Sam, I will take you for a walk soon; promise! I thank my advisor (D. J. Orth) and my committee (P. L. Angermeier, J. J. Ney, E. P. Smith, and P. Diplas) for their work in shaping my research and me. I also acknowledge the other faculty and staff of the Fisheries and Wildlife Science department for the numerous occasions that I sought their advice on a variety of classroom, dissertation, or life issues, in particular R. L. Kirkpatrick, B. R. Murphy, D. R. Novinger, T. J. Newcomb, and E. M. Hallerman. I am grateful to the students of the department and university for the opportunity to have served in FIWGSA (fisheries and wildlife graduate student association) and GSA (university graduate student assembly) and help shape issues and hopefully improve graduate student life at Virginia Tech. I greatly appreciate the many friendships and that evolved from working with the wonderful graduate students of the department of fisheries and wildlife sciences; they have been and continue to be a truly unique and special group. Outside of the department, I acknowledge my dear friend, L. Giese; I will miss our conversations over good food and wine. Special thanks to D. D. Black for her unique support, especially wake-up calls in final days of writing. I also thank my friends, S. Haskill and S. Becker, for allowing me to work at their winery and vineyard over the last year; your friendship served as a special retreat away from campus life. I acknowledge the help of all individuals initiated into the growing population of Orthlings, in particular R. K. Smith and V. F. Stancil.

This research was only possible with direct support of labor and financial resources from many different sources. Herein I attempt to acknowledge all individuals and groups that have contributed over the last four years and I apologize if I have left anyone out. I thank C. Roghair, L. M. Colie, M. Rummel, C. Markum, and J. Grist for making numerous, tedious morphology measurements. I thank T. Lentz for his assistance with conducting swimming performance trials. Financial assistance for this research was provided in numerous small pieces. I thank my advisor,

D. J. Orth, for his financial support of my graduate work, especially for his willingness to fund travel to professional meetings. Meetings greatly contributed to my education, equal to what I learned on campus. I thank the following groups for their financial commitments: USGS Biological Resources Division, Sigma Xi, Virginia Natural History Museum, and GSA Graduate Research, and Development Fund for equipment and salary, grants from the Department of Fisheries and Wildlife Sciences, GSA Travel Fund and AFS Southern Division Student Committee for providing transportation and rooms at professional meetings, and the Dr. J. F. Hosner Scholarship (Colonial Agricultural Education Foundation). I also thank the Virginia Department of Game and Inland Fisheries for sampling permits and Dr. R. E. Jenkins for access to museum collections of endangered species at Roanoke College.

Finally, I dedicate this volume to the vision of conserving the experience, the beauty, the diversity, the processes, and unique and rare elements of natural resources which are directly responsible for a high quality of life, especially those elements of the aquatic realm.

Table of Contents

Introduction	1
Chapter 1. Ecomorphological guilds: Predicting membership of warmwater stream fishes in habitat guilds from morphology.	7
Abstract	7
Introduction	8
Material and Methods	16
Guild Classification Systems	16
Fish collection	17
Morphology measurements	19
Statistical Software	20
Preliminary Analysis	20
Univariate Analysis	21
Multivariate Analysis	21
Testing Factors Influencing Classification Rates	22
Removing Individual Species Before Variable Selection	22
Removing Individual Species Immediately Before Discriminant Function Construction	22
Removing Guilds with Poor Classification	22
Effect of Data Set Size on Classification Rates	23
Effect of Sample Size of Species on Same Species Classification	23
Effect of Collection Site on Species Classification Error	23
Transferability of Morphological Functions	23
Results	27
Preliminary Analysis	27
Univariate Analysis	30
Multivariate Analysis	33
Microhabitat Guild Model Testing	43
Removing Individual Species Before Variable Selection	43
Removing Individual Species Immediately Before Discriminant Function Construction	46
Removing Guilds with the Highest Mis-Classification	48
Effect of Data Set Size on Classification Rates	49
Effect of Sample Size of Species on Same Species Classification	49
Effect of Collection Site on Species Classification Rates	51
Transferability of Discriminant Functions	51
Discussion	55

Chapter 2. A phylogenetic approach to using surrogate species: Do closely-related surrogate species tell us more than distant relatives?	63
Abstract	63
Introduction	64
Methods	66
Results	70
Discussion	73
Chapter 3. Ecomorphological guilds: an approach to identifying habitat preference using a simple hydraulic variable and fish morphology	78
Abstract	78
Introduction	79
Methods	82
Fish collection	82
Morphology measurements	82
Habitat Data	82
Statistical Analysis	83
Results	83
Discussion	89
Chapter 4. Ecomorphological relationships of warmwater stream cyprinids, linking morphology, swimming performance, and habitat preference.	94
Abstract	94
Introduction	95
Methods	99
Results	102
Discussion	112
Summary	117
Chapter 1 Summary	117
Chapter 2 Summary	118
Chapter 3 summary	120
Chapter 4 summary	121
Conclusions and Management Implications	123
Literature Cited	127
Appendix A. Morphology measurements	142
Appendix B. Box plots	145
Appendix C. Correlation between morphology measurements	192

Appendix D. Principal components analysis	200
Appendix E. Mean differences of univariate analysis	206
Appendix F. Habitat references	212
Appendix G. Correlations of morphology within fish families	226
Vitae	252

List of Tables

Table 1.1. Fish species and sample sizes used in this study listed by microhabitat and mesohabitat guild classification (Vadas and Orth, 2000).	18
Table 1.2. Species in each of two data sets used to test the transferability of morphology traits for identification of habitat guilds. <i>A priori</i> (before testing) guild assignments are given, acronyms are as follows: FG=fast-generalist, FR=fast-riffle, PC=pool-covered, PO=pool open, PR=pool-run, RR=riffle-run, and SR=shallow-rheophilic. Species of the Virginia T&E data are listed as threatened or endangered in Virginia. Fishes of the Powell River are also from Virginia.	24
Table 1.3. In order to classify species to habitat guilds <i>a priori</i> for comparisons with results of morphology predictions, habitat thresholds for guilds of the Roanoke River were established. Criteria were derived by examining figures of habitat use (Vadas and Orth, 2000), which report the range of mean habitat used by each species for each variable. Criteria for each guild were based on this data for all species within the guild and were assigned because they encompassed both the majority of overlapping habitat used by species and contained the mid-point of the range of habitat for all species.	26
Table 1.4. Results of unbalanced ANOVA tests of trait means among microhabitat guilds. Tests that were significant at $p < 0.05$ are in bold lettering and include axial caudal fin length (ACFL), caudal fin depth (CFD), total length of dorsal fins (TLDF), pectoral fin length (PFL), eye location (EYELOC), and distance from pelvic to anal fin (PELAF). Measurements are illustrated in Appendix A.	31
Table 1.5. Results of unbalanced ANOVA tests of trait means among mesohabitat guilds. Tests that were significant at $p < 0.05$ are in bold lettering and include caudal fin depth (CFD), total length of dorsal fins (TLDF), pectoral fin length (PFL), distance from pectoral fin to pelvic fin (PECPEL), distance from posterior of neurocranium to dorsal fin (PNERDF), distance from anal fin to ventral membrane of caudal fin (AFVMCF), and distance from pelvic fin to anal fin (PELAF). Measurements are illustrated in Appendix A.	32
Table 1.6. The fifteen shape variables selected from all variables examined and used in discriminant functions.	34
Table 1.7. List of coefficients for discriminant functions of the seven microhabitat guilds (Roanoke River, VA). Microhabitat guild acronyms are as follows: FG=fast-generalist, FR=fast-riffle, PC=pool-covered, PO=pool open, PR=pool-run, RR=riffle-run, and SR=shallow-rheophilic. See Table 1.2 and Table 1.3 for descriptions of the variables.	35

Table 1.8. A list of coefficients for linear discriminant functions of the three mesohabitat guilds (Roanoke River, VA). TLDF is total length of dorsal fins. MBD is maximum body depth and CFL is caudal fin length. 35

Table 1.9. Generalized squared distances between microhabitat guilds from discriminant analysis. The matrix is symmetrical about the diagonal axis, therefore only the upper portion is given. Guild acronyms are as follows: FG=fast-generalist, FR=fast-riffle, PC=pool-covered, PO=pool open, PR=pool-run, RR=riffle-run, and SR=shallow-rheophilic. . . . 37

Table 1.10. Generalized squared distances between mesohabitat guilds from discriminant analysis. The matrix is symmetrical about the diagonal axis, therefore only the upper portion is given. 37

Table 1.11. Summary of resubstitution error (using holdout procedure) for data set of common Roanoke River fishes used to create the morphology discriminant functions to identify microhabitat guild membership. Microhabitat guild acronyms are as follows: FG=fast-generalist, FR=fast-riffle, PC=pool-covered, PO=pool open, PR=pool-run, RR=riffle-run, and SR=shallow-rheophilic. Priors are the prior probability of an observation being placed into a guild, in this case all guilds had equal prior probabilities. 38

Table 1.12. Number of fish (#) and percent of fishes (%) classified from each microhabitat guild (*a priori* classification based on habitat) into the same set of microhabitat guilds based on morphology discriminant functions during holdout tests. 40

Table 1.13. A list of species with misclassification error during the resubstitution test of the morphology discriminant functions for identifying microhabitat guild membership. The “From Guild” is the *a priori* classification based on reported habitat use. 41

Table 1.14. Number of fish (#) and percent of fish (%) classified from each mesohabitat guild (*a priori* classification based on habitat) into the same set of mesohabitat guilds based on morphology discriminant functions during the holdout test. 42

Table 1.15. Number of fish and percent of fish (%) classified by morphological functions into each microhabitat guild for Virginia threatened and endangered fish species. Guild acronyms are as follows: FG=fast-generalist, FR=fast-riffle, PC=pool-covered, PO=pool open, PR=pool-run, RR=riffle-run, and SR=shallow-rheophilic. 53

Table 1.16. Number of observations (individual fish) and percent classified by morphology discriminant functions into each microhabitat guild for Powell River species. Guild acronyms are as follows: FG=fast-generalist, FR=fast-riffle, PC=pool-covered, PO=pool-open, PR=pool-run, RR=riffle-run, and SR=shallow-rheophilic. 54

Table 2.1. Examples of how overlap in habitat use was determined for pairs of fish species, using mesohabitat, water depth, and water velocity categories. 70

Table 2.2. The percent of pairs having habitat overlap within different types of comparisons. The number of pairs having overlap is given over the number of comparisons made in parentheses. 72

Table 3.1. Statistically significant regressions ($p < 0.05$) for morphology traits versus Froude number. 84

Table 4.1. Mean swimming performance of eight cyprinids from the upper Roanoke River, Virginia. Mean swimming speed calculated with average fish length (8.3 cm) and mean water temperature (16.9 °C) as covariates are reported as Adjusted U_{crit} . One standard deviation (italics) is reported below mean swimming performance, total length, and temperature. *Clinostomus funduloides* and *Luxilus cerasinus* were the only pair to have statistically different means (p -value=0.04) using pairwise comparisons of adjusted mean swimming performance. 104

Table 4.2. Results of regressions of swimming performance against morphological traits or habitat use. Swimming performance was not adjusted for water temperature. Body length per second was calculated as mean performance divided by mean body length for each species. 105

List of Figures

- Figure 1.1. A hierarchy of environmental filters influencing habitat use of fish species at the local scale. Interactions of morphology and habitat filters at the local scale are shown to the right of filters. 10
- Figure 1.2. An illustration of the relationship of evolutionary history (genotype), phenotype (including morphology), and habitat use, including interaction of environmental filters. Habitat use influences morphology through evolution. Through comparative study, current resource use may be interpreted based on evolutionary histories of phenotypes. 12
- Figure 1.3. Plot of microhabitat guilds as 95% confidence ellipses around samples on the first (abscissa) and second principal components (ordinate). Guild acronyms are as follows: 30
- Figure 1.4. The effect of changing the significance level for variables to stay and enter on the number of variables selected by stepwise discriminant analysis. The trade off among the number of variables in the model and holdout test misclassification rate was used to determine the number of variables to keep in the model. 33
- Figure 1.5. Microhabitat guilds plotted with 95% confidence ellipses for samples on the first (abscissa) and second canonical variate functions (ordinate). Guild acronyms are as follows: FG = fast-generalist, FR = fast-riffle, PC = pool-covered, PO = pool-open, PR = pool-run, RR = riffle-run, and SR = shallow-rheophilic. 39
- Figure 1.6. Mesohabitat guilds plotted with 95% confidence ellipses for samples on the first (abscissa) and second (ordinate) canonical variate functions. 43
- Figure 1.7. The morphology measurements selected during stepwise analysis and their frequency of addition when each species of fish was removed from the model, one at a time, before stepwise discriminant analysis. All measurements except MDFSMDB and TRUNK were divided by fish standard length. MBD = maximum body depth. MDFSMDB = maximum dorsal fin span divided by maximum body depth. EYESIZE = eye size. PFW = pectoral fin width. PECPEL = distance between anterior of pectoral fin and anterior of pelvic fin. CFL = caudal fin length. Trunk = Maximum body depth divided by maximum body width. 44

Figure 1.8. The morphology measurements that were no longer selected for the model and their frequency with which they were removed as each species was removed, one at a time, before stepwise discriminant analysis was performed. PECAREA = pectoral fin area. All variables were standardized to fish standard length. HD = head depth. CPD = caudal peduncle depth. PFL = pectoral fin length. PELAF = distance between anterior of pelvic fin and anterior of anal fin. ACFL = axial caudal fin length. MAXPEC = distance from the posterior of maxillary to anterior of pectoral fin. 45

Figure 1.9. The difference in error rate shows how the alternative model (created by removing one species before stepwise discriminant analysis) fared relative to the model with all species in a comparison of total posterior misclassification rates. CaAn = *Campostoma anomalum*. CaCo = *Catostomus commersoni*. CoBa = *Cottus bairdi*. EtFl = *Etheostoma flabellare*. EtPo = *Etheostoma podostemone*. HyNi = *Hypentelium nigricans*. HyRo = *Hypentelium roanokense*. LeAu = *Lepomis auritus*. LuAl = *Luxilus albeolus*. LuCe = *Luxilus cerasinus*. MoAn = *Moxostoma anisurum*. MoEr = *Moxostoma erythrurum*. NoHu = *Notropis hudsonius*. NoIn = *Noturus insignis*. NoLe = *Nocomis leptcephalus*. NoPr = *Notropis procne*. NoVo = *Notropis volucellus*. PeRo = *Percina roanoka*. PhOr = *Phoxinus oreas*. PiNo = *Pimephales notatus*. RhAt = *Rhinichthys atratulus atratulus*. ScCe = *Scartomyzon cervinus*. ThRh = *Thoburnia rathoeca*. 46

Figure 1.10. The effect of removing a species from the data set after model variables have been selected (post-stepwise discriminant analysis), but prior to calculating the discriminant functions (pre-discriminant analysis), on the total misclassification error (compared to the model when all species have been used). CaAn = *Campostoma anomalum*. CaCo = *Catostomus commersoni*. CoBa = *Cottus bairdi*. EtFl = *Etheostoma flabellare*. EtPo = *Etheostoma podostemone*. HyNi = *Hypentelium nigricans*. HyRo = *Hypentelium roanokense*. LeAu = *Lepomis auritus*. LuAl = *Luxilus albeolus*. LuCe = *Luxilus cerasinus*. MoAn = *Moxostoma anisurum*. MoEr = *Moxostoma erythrurum*. NoHu = *Notropis hudsonius*. NoIn = *Noturus insignis*. NoLe = *Nocomis leptcephalus*. NoPr = *Notropis procne*. NoVo = *Notropis volucellus*. PeRo = *Percina roanoka*. PhOr = *Phoxinus oreas*. PiNo = *Pimephales notatus*. RhAt = *Rhinichthys atratulus atratulus*. ScCe = *Scartomyzon cervinus*. ThRh = *Thoburnia rathoeca* 47

Figure 1.11. The percent of individuals of a species that were misclassified when each species was not used to select variables for morphological functions to identify guild membership. Sample sizes for each species are shown at the top of each column. Error rates were lowest for removed species that had a related species of the same genus and guild still in the model (such as *Notropis*, *Luxilus* and *Etheostoma*) and highest (almost 100%) for those species that had no related species in the model. CaAn = *Campostoma anomalum*. CaCo = *Catostomus commersoni*. CoBa = *Cottus bairdi*. EtFl = *Etheostoma flabellare*. EtPo = *Etheostoma podostemone*. HyNi = *Hypentelium nigricans*. HyRo = *Hypentelium roanokense*. LeAu = *Lepomis auritus*. LuAl = *Luxilus albeolus*. LuCe = *Luxilus cerasinus*. MoAn = *Moxostoma anisurum*. MoEr = *Moxostoma erythrurum*. NoHu = *Notropis hudsonius*. NoIn = *Noturus insignis*. NoLe = *Nocomis leptcephalus*. NoPr = *Notropis procne*. NoVo = *Notropis volucellus*. PeRo = *Percina roanoka*. PhOr = *Phoxinus oreas*. PiNo = *Pimephales notatus*. RhAt = *Rhinichthys atratulus atratulus*. ScCe = *Scartomyzon cervinus*. ThRh = *Thoburnia rhothoeca*. 48

Figure 1.12. The results of randomly removing a percentage of the data (10%, 25%, or 50%) set on total posterior misclassification rates for habitat guilds (FG = fast-generalist, FR = fast-riffle, PC = pool-covered, PO = pool-open, PR = pool-run, RR = riffle-run, SR = shallow-rheophilic) and overall model error (Total). 50

Figure 1.13. A plot of posterior classification error of withheld individuals of a species when either five or 20 individuals of the same species were used in the construction of discriminant functions. EtFl = *Etheostoma flabellare*. EtPo = *Etheostoma podostemone*. LuCe = *Luxilus cerasinus*. PhOr = *Phoxinus oreas*. RhAt = *Rhinichthys atratulus atratulus*. ThRh = *Thoburnia rhothoeca*. 50

Figure 1.14. The rates of misclassification for individuals of a species when discriminant functions were constructed from other individuals of that same species, collected at only one sampling site. Fantail darter = *Etheostoma flabellare*. Riverweed darter = *Etheostoma podostemone*. Crescent shiner = *Luxilus cerasinus*. Mountain redbelly dace = *Phoxinus oreas*. Blacknose dace = *Rhinichthys atratulus atratulus*. Torrent sucker = *Thoburnia rhothoeca*. 52

Figure 2.1. Three possible scenarios faced by a researcher attempting to determine the nearest relative of a species. The target species is labeled **B**. In the first scenario, species **A** and **B** are considered sister taxa. In the second and third scenarios, both species **A** and **C** were considered as viable surrogates for the target species. 67

Figure 3.1. Surface plot of Froude number based on typical values for water velocity and water depth measurements in streams. Bands represent similar Froude values and therefore similar water flow characteristics across different combinations of depth and velocity. 81

Figure 3.2. Plot of caudal peduncle length (percent of standard length) versus Froude number (from habitat use) for darters ($p=0.01$, $r^2=0.54$). Dotted lines are 95% confidence intervals. Acronyms for species are as follows: PeAu = *Percina aurantiaca*, PeRo = *Percina roanoka*, PeEv = *Percina evides*, PeRe = *Percina rex*, EtFl = *Etheostoma flabellare*, EtPo = *Etheostoma podostemone*, EtBl = *Etheostoma blennioides*, EtRu = *Etheostoma rufilineatum*, EtZo = *Etheostoma zonale*, and EtSi = *Etheostoma simoterum*. 85

Figure 3.3. Plot of the distance between pectoral fin and pelvic fin (percent of standard length) versus Froude number for average habitat use of darters ($p=0.03$, $r^2=0.43$). Dotted lines are 95% confidence intervals. Acronyms for species are as follows: PeAu = *Percina aurantiaca*, PeRo = *Percina roanoka*, PeEv = *Percina evides*, PeRe = *Percina rex*, EtFl = *Etheostoma flabellare*, EtPo = *Etheostoma podostemone*, EtBl = *Etheostoma blennioides*, EtRu = *Etheostoma rufilineatum*, EtZo = *Etheostoma zonale*, and EtSi = *Etheostoma simoterum*. 85

Figure 3.4. Plot of vertical height of the eye on head versus Froude number for benthic minnows ($p=0.04$, $r^2=0.46$). Dotted lines represent 95% confidence intervals. Acronyms are as follows: CaAn = *Campostoma anomalum*, ErIn = *Erimystax insignis*, HyAm = *Hybopsis amblops*, NoLe = *Nocomis leptocephalus*, NoMi = *Nocomis micropogon*, PhUr = *Phenacobius uranops*, and RhAt = *Rhinichthys atratulus*. 86

Figure 3.5. Plot of caudal peduncle length (percent of standard length) versus Froude number for benthic minnows ($p=0.03$, $r^2=0.52$). Dotted lines represent 95% confidence intervals. Acronyms are as follows: CaAn = *Campostoma anomalum*, ErIn = *Erimystax insignis*, HyAm = *Hybopsis amblops*, NoLe = *Nocomis leptocephalus*, NoMi = *Nocomis micropogon*, PhUr = *Phenacobius uranops*, and RhAt = *Rhinichthys atratulus*. 87

Figure 3.6. Plot of distance from maxillary to pectoral fin (percent of standard length) versus Froude number for benthic minnows ($p=0.001$, adjusted $r^2=0.80$). Dotted lines represent 95% confidence intervals. Acronyms are as follows: CaAn = *Campostoma anomalum*, ErIn = *Erimystax insignis*, HyAm = *Hybopsis amblops*, NoLe = *Nocomis leptocephalus*, NoMi = *Nocomis micropogon*, PhUr = *Phenacobius uranops*, and RhAt = *Rhinichthys atratulus*. 87

Figure 3.7. Plot of distance from pelvic fin to anal fin (percent of standard length) versus Froude number (from habitat use) of pelagic minnows ($p=0.001$, adjusted $r^2=0.64$). Dotted lines represent 95% confidence intervals. Acronyms are as follows: CyGa = *Cyprinella galactura*, LuCe = *Luxilus cerasinus*, LuAl = *Luxilus albeolus*, LuCh = *Luxilus chrysocephalus*, LuCo = *Luxilus coccogenis*, NLeu = *Notropis leuciodus*, NoTe = *Notropis telescopus*, NoVo = *Notropis volucellus*, NoPr = *Notropis procne*, NoHu = *Notropis hudsonius*, PhOr = *Phoxinus oreas*, and PiNo = *Pimephales notatus*. 88

Figure 3.8. Plot of pectoral fin length (percent of standard length) versus Froude number (from habitat use) for suckers ($p= 0.05$, $r^2= 0.77$). Dotted lines represent 95% confidence intervals. Acronyms are as follows: ThRh = *Thoburnia rathoeca*, ScCe = *Scartomyzon cervinum*, CaCo = *Catostomus commersoni*, HyNi = *Hypentelium nigricans*, and HyRo = *Hypentelium roanokense*. 89

Figure 4.1. Plot of critical swimming speed against length of individual and trial temperature for eight species of minnows: *Notropis hudsonius* (samples=2); *Clinostomus funduloides* (samples=11); *Luxilus cerasinus* (samples=19); *Nocomis leptoccephalus* (samples=2); *Luxilus albeolus* (samples=20); *Lythurus ardens* (samples=13); *Phoxinus oreas* (samples=17); *Campostoma anomalum* (samples=1). 106

Figure 4.2. Swimming ability of *Clinostomus funduloides* versus water temperature (° C). . . 107

Figure 4.3. Swimming ability of *Luxilus albeolus* versus water temperature (° C). 107

Figure 4.4. Swimming ability of *Lythurus ardens* versus water temperature (° C). 108

Figure 4.5. Swimming ability of *Luxilus cerasinus* versus water temperature (° C). 108

Figure 4.6. Swimming ability of *Phoxinus oreas* versus water temperature (° C). 109

Figure 4.7. Average habitat use as reported in literature relative to swimming ability. The midpoint mean velocity represents the middle of the range of mean velocities observed for each species over two years and several sampling sites (Vadas and Orth 2000). The maximum mean velocity was the maximum velocity reported for the same data (Vadas and Orth 2000). Habitat data for rosyside dace was provided by Facey and Grossman (1992). Acronyms are *Notropis hudsonius* (NoHu), *Clinostomus funduloides* (ClFu), *Luxilus cerasinus* (LuCe), *Nocomis leptoccephalus* (NoLe), *Luxilus albeolus* (LuAl), *Phoxinus oreas* (PhOr), *Lythurus ardens* (LyAr), and *Campostoma anomalum* (CaAn). 109

Figure 4.8. Plot of swimming performance versus maximum mean water velocity used as reported in the literature for *Notropis hudsonius* (NoHu), *Clinostomus funduloides* (ClFu), *Luxilus cerasinus* (LuCe), *Nocomis leptoccephalus* (NoLe), *Luxilus albeolus* (LuAl), *Phoxinus oreas* (PhOr), *Lythurus ardens* (LyAr), and *Campostoma anomalum* (CaAn). 111

Figure 4.9. Plot of the distance from pectoral fin to pelvic fin (standardized to standard length) versus swimming ability (body lengths/sec) for seven minnows, including *Notropis hudsonius* (NoHu), *Clinostomus funduloides* (ClFu), *Luxilus cerasinus* (LuCe), *Nocomis leptoccephalus* (NoLe), *Luxilus albeolus* (LuAl), *Phoxinus oreas* (PhOr), *Lythurus ardens* (LyAr), and *Campostoma anomalum* (CaAn). 111

Figure 4.10. Plot of caudal fin aspect ratio versus critical swimming speed (cm/s) for seven minnows, including *Notropis hudsonius* (NoHu), *Clinostomus funduloides* (ClFu), *Luxilus cerasinus* (LuCe), *Nocomis leptocephalus* (NoLe), *Luxilus albeolus* (LuAl), *Phoxinus oreas* (PhOr), *Lythurus ardens* (LyAr), and *Campostoma anomalum* (CaAn).

..... 112

Introduction

Freshwater species of many taxa are declining due to increased stresses placed on freshwater resources from human populations. Habitat destruction and alteration have been identified as the primary reason for the decline of myriad fish species (Warren et al., 2000) and other aquatic organisms. The Nature Conservancy reported that 39% of freshwater fish species are at risk, along with 67% and 51% of freshwater mussels and crayfish, respectively, and 40% of amphibian species (TNC, 1997). In the southern United States, 28% of extant fishes are recognized as either extinct (6%), threatened (7%), or vulnerable status (15%) status (Warren et al., 2000). In Tennessee, of 56 taxa of fish jeopardized throughout their range, all occur in lotic habitats with a large number occurring in medium-size rivers and springs (Etnier and Starnes, 1991). Habitat alteration such as impoundments, channelization, dredging, sedimentation and flow modification are frequent causes of risk (Etnier and Starnes, 1991; Warren et al., 2000). In addition to fishes, 50% of crayfishes are imperiled according to a report on the conservation status of crayfishes in the United States (Taylor et al., 1996). The primary factor for crayfish imperilment was limited natural range which causes crayfish species to be vulnerable to habitat destruction and degradation from the same stress factors as fishes (Taylor et al., 1996). The increasing amount of land being developed into urban areas threatens streams even more with hydrological changes, riparian destruction, pollutants (non-point source, storm runoff), and channelization and fragmentation (dams, road crossings) (Chocat et al., 1998; Warren and Pardew, 1998; Hall et al., 1999; Toepfer et al., 1999; Wong and Li, 1999; Williams et al., 2000).

In addition to changing patterns of land use, recent reports on global weather patterns suggest those extreme events such as drought, heat waves and floods will probably increase (Easterling et al., 2000) Spatial shifts in rainfall which will require areas previously not prone to frequent droughts to increase water management in order to maintain environmental resources, economies and quality of life standards.

Attempts to limit instream habitat degradation generally involve an assessment of changes in habitat quantity with stepwise changes in discharge under the assumption that habitat quantity is a limiting factor for aquatic species. Currently, the most widely used method of evaluating such

changes is IFIM, Instream Flow Incremental Methodology (Moyle and Baltz, 1985). IFIM consists of three main components, a temperature model, water quality model, and physical habitat model. For evaluating physical habitat changes, IFIM relies on a one-dimensional flow model (PHABSIM, Physical Habitat Simulation Model) for evaluating habitat changes (Milhous et al. 1989).

Recently, the effectiveness of IFIM(PHABSIM) has been roundly criticized. Some of the strongest criticisms and current needs for IFIM are that the relationship between flow, habitat, and fish production has not been identified (Bain and Boltz, 1989; Stalnaker, 1995). In some systems, such as warmwater streams, habitat may not be limiting most of the time, and in all cases, habitat models will not incorporate every habitat parameter that could be important at some time (Leonard and Orth, 1988; Bain and Boltz, 1989). Bain and Boltz (1989) convincingly argue that evaluating the suitability and availability of a habitat is still needed because habitats may become limiting at some time; evaluations need only assess the habitat components that are anticipated to change with alternative flows.

Another valid and strong criticism of IFIM was provided by Castleberry et al. (1996). The authors claim that there is no scientifically defensible [hypothesis generating and testing] method for defining flow standards because PHABSIM is not such a method. In response to this dilemma, Castleberry et al. (1996) prescribe adaptive management, although not all authors of the manuscript agreed that PHABSIM could generate useful information with careful use and some modification. Van Winkle et al. (1997) point out that adaptive management may have political and social implications which currently make it an impractical method of dealing with uncertainty of flow standards. They also point out that IFIM/PHABSIM is one methodology that provides quantitative predictions of fish response to alternative instream flow regimes where no such methodology exists for adaptive management.

Habitat modeling has had limited success because it relies on empirical measures of habitat use (HSI, habitat suitability indices). Even though fish respond to changes in a habitat at a local scale (Matthews, 1998), observations of microhabitat use have consistently been poor predictors of future use both temporally and spatially. Habitat use varies among years (Angermeier, 1987), streams (Thomas and Bovee, 1993; P.G.& E., 1994), and drainage (Angermeier, 1987). Despite

the recognized problems of PHABSIM, the core of IFIM analyses, many researchers argue there is no better alternative (Van Winkle et al., 1997) and it continues to be widely used and revised.

Another problem with IFIM(PHABSIM) and using empirically derived measures of habitat use arises in fish communities with large numbers of species. IFIM was developed for use in coldwater streams of the western U.S. where the number of species per community is relatively low (<10) (Moyle and Baltz, 1985), making it possible to analyze all or most species/life-stage combinations. However, in warmwater streams such data is lacking for most species and developing criteria becomes prohibitively expensive and time consuming for most projects because of the high fish diversity. In addition, developed criteria from other streams and rivers may not be transferable.

To overcome problems associated with a multi-species approach, community metrics such as habitat guilds have been proposed (Leonard and Orth, 1988). A guild is a set of organisms, regardless of taxonomic composition, i.e., regardless of family), that use the same class of environmental resources, e.g., riffles (Fauth et al., 1996). In this case, the resource of concern is habitat and the organisms are fishes, regardless of taxonomic status such as subspecies, species, or family. For clarity Fauth et al. (1996) described resource use as consumption, meaning that use of a resource made it potentially unavailable to others, and local guilds as organisms in the same guild occurring in the same place and time. Guilds often have been used to describe resource use of fishes, including habitat guilds (Vadas and Orth, 1997), trophic guilds (Sibbing et al., 1994), and reproductive guilds (Balon, 1975).

Within PHABSIM, guild habitat criteria could be used in place of species/life-stage criteria to reduce the unwieldy diversity of fish communities into a manageable and more understandable number of units. However, guilds still require quantitative habitat data for proper membership determination and, therefore, the approach suffers from a similar problem as the species-approach. Consequently, the major weakness of PHABSIM has been no scientifically defensible method for classifying species according to habitat use without actually measuring habitat use. Despite the approach used, reliable models are needed for decision making and the models need reliable habitat use limits or tolerances. Approaches for developing such methodology may already be available through mechanistic research strategies (Schoener, 1986).

A defensible method of predicting habitat use may be derived from mechanistic approaches to ecology. Schoener (1986) states that “mechanistic approaches to community ecology are those which employ individual-ecological concepts—those of behavioral ecology, physiological ecology, and ecomorphology—as theoretical bases.” Such approaches have been successful in understanding resource use at the individual level (microhabitat scale). For example, Werner and Hall (1988) successfully predicted habitat shifts related to changes in feeding strategy. Sagnes et al. (1997) demonstrated that ontogenetic shifts in habitat (water velocities) were related to improved hydrodynamic shape with growth. Further, individual-based models of resource use have already been successful at describing population level ecology of fisheries (Clark and Rose, 1997, Van Winkle et al., 1998; Rose et al., 1999). Such models illustrate that mechanistic approaches at the level of individuals can be used to infer population and community level ecology.

The theoretical basis for such approaches is more defensible because they rely on behavioral, physiological and functional mechanisms and such approaches are reductionist (hierarchical); results at the individual level are used to infer patterns (hypothesis generation) of resource use at higher organizational levels (Schoener, 1986). For example, arboreal lizards are functionally constrained to a maximum jumping distance by size and form (Moermond, 1979, 1986). This constraint has larger implications for lizard ecology, such as habitat distribution. Based on an understanding of the lizard’s functional-morphology, its jumping ability is predictable and can be used to identify the lizard’s potential niche in a vegetation patch, the “potential” niche being an area of the vegetation available to the lizard in the absence of competition or predation. These results suggest that an obvious starting point for constructing a solid theoretical foundation for modeling habitat use of fishes would be an ecomorphological approach.

Ecomorphology is the study of relationships of form and environmental factors as an attempt to isolate the contribution of one on the other (Motta et al., 1995b), i.e., it attempts “to understand the interrelationships between morphological variation among individuals, populations, species and higher taxa, and communities and the corresponding variation in their ecology” (Liesler and Winkler, 1985). Form constrains the use of resources through performance of important tasks and resource availability helps construct the form (via evolution) by determining

which tasks are most important for increased fitness.

Because one of the principles of ecomorphology is that morphology constrains resource use, it fits well with contemporary theories of resource use, i.e., habitat templet theory). Habitat templet theory suggests “habitat filters,” abiotic factors, constrain an individual’s resource use (spatial distribution) through physiological or morphological mechanisms at different, hierarchal scales (Poff, 1997), including the community (microhabitat). Habitat templet theory incorporates strong morphology-ecology relationships found across taxa. However, research to generate an understanding of cause and effect between morphology and habitat of fishes and capable of strong predictive ability for habitat use, especially at the microhabitat level, has been lacking. Therefore, an ecomorphology framework may provide the habitat filter for a scientifically defensible method of identifying guild membership, habitat use, for IFIM analysis and community ecology structure.

To investigate the use of ecomorphology to reliably define habitat use or limits of use, three approaches to using ecomorphology for predicting habitat use in warmwater fishes were investigated. In Chapter 1, the use of morphology to classify species into habitat guilds (the first ecomorphology approach) is investigated. Using common fishes of the upper Roanoke River watershed and seven predefined microhabitat guilds, morphology measurements and discriminant analysis were used to create linear mathematical functions for identifying guild membership. The ability of these functions to categorize species into habitat guilds was then tested with minnows and darters of the Powell River.

In Chapter 2, a phylogenetic methodology, the second approach, for determining habitat use was investigated. When information for target species is scarce or absent, resource managers commonly apply knowledge garnered from related species, surrogates, to their decision making process. This phylogenetic approach is often applied in practice, yet no thorough review of the approach has been conducted. In this study, the use of mesohabitat and microhabitat by target species was compared against the same for surrogate species. Surrogate species were the closest extant relative to the target species according to the most recent phylogenetic data available.

In Chapters 3, the use of morphology to directly predict habitat use, the third ecomorphological approach, was investigated. I investigated the relationship of a complex hydraulic variable, an index of habitat conditions, to morphology of fishes. Complex hydraulic

variables are more descriptive of a habitat, particularly so because some may be used to describe habitat gradients, which are important to fishes. In this study, linear regression was used to examine relationships between morphology traits and Froude number for four groups of fishes (darters, benthic and pelagic minnows, and suckers).

The central idea of ecomorphology is that morphological design limits the ability of organisms to perform key daily tasks. In the final chapter, Chapter 4, I examined the relationships of morphology to swimming performance and the relationship of swimming performance and habitat use, linking morphology, function ability, and resource use. This study applied the third ecomorphological approach (direct prediction) but in a different manner, i.e., not directly to habitat use, but to factors limiting habitat use). Critical swimming performance of eight cyprinids was determined in a swim tunnel. Relationships of performance were then regressed against morphological indices of body shape related to swimming ability, using linear regression. Similarly, habitat use (Froude number) was regressed against swimming performance to examine the ability of swimming to determine habitat use.

Chapter 1. Ecomorphological guilds: Predicting membership of warmwater stream fishes in habitat guilds from morphology.

Abstract

A major challenge to evaluating flow changes on instream habitats in warmwater streams is fish diversity. Habitat guilds have been suggested to simplify analysis of fish assemblages, but proper guild classification relies on prior knowledge of microhabitat use, which is lacking for many species. In this study, a novel methodology (ecomorphology) for grouping fishes into habitat guilds was tested. Morphological discriminant functions were used to classify 23 fishes into two guild systems (a seven-guild microhabitat system and a three-guild mesohabitat system). Examining posterior misclassification rates, the seven-guild system had lower misclassification rates than the three-guild system because it allowed for more explicit identification of morphology and habitat relationships, i.e., the seven-guild system did not aggregate as many different body forms and lifestyles into each guild as the three-guild system did. Guilds of generalist species were not intermediate in body shape between fast-water and slow-water habitat types and did not experience the highest misclassification error as might be expected of species without strong habitat affinities. Further, guilds of more extreme physical environments, i.e., fast-water habitats, did not have the highest classification success as might be expected for species that need strong morphological adaptations to perform well in their habitat. In both guild systems, most misclassifications were among guilds of closely related habitat types, suggesting that gross external morphology will not be able to distinguish among some habitat types. In a validation test with species of a second drainage, morphology was only partly successful (50%) at predicting habitat use. Morphology correctly grouped species by shape, i.e., test fish were classified into guilds with fishes of the same genus or general shape, but did not identify habitat use because morphology and habitat were not closely associated through function, i.e., key tasks required to use a habitat). Morphology will be most successful at predicting habitat use of fishes when (1) more, discrete guilds are used, (2) guilds are identified within families, (3) variation in the lifestyle (benthic vs. pelagic) is explicitly considered, and (4) key tasks related to habitat use are strongly associated with fish morphology. Separate guild frameworks for habitat identification

(ecomorphological guilds) and flow analysis (habitat guilds) can be used together. The ecomorphological guild system having more, discrete habitat types can more easily identify habitat use. Once habitat use is established, the ecomorphological guilds can be condensed across families and lifestyles into a simpler habitat guild framework for instream flow analysis. Ecomorphology offers a mechanistic and defensible method for identifying habitat preferences of fishes and should be more widely considered as a potential tool for flow-habitat analysis of warmwater streams.

Introduction

In situations where human activities will alter stream discharge, authorities must consider the trade-off between instream habitat and human water use. A major challenge to evaluating flow changes on instream habitat in warmwater streams is fish diversity. The most widely used method of evaluating instream flow changes, the Instream Flow Incremental Methodology or IFIM (Bovee, 1995) was developed for use on streams in the western United States which typically have low fish diversity (average of five fishes) (Matthews, 1998), but warmwater streams, around the world, have much higher numbers of species (Matthews, 1998). Because IFIM relies heavily on the availability of quantitative data for microhabitat preferences (Karim et al., 1995), developing habitat suitability criteria or HSC (Bovee, 1986) for each life stage of all species of a warmwater system is prohibitively expensive. Unfortunately, the transferability of HSC among streams is questionable (Thomas and Bovee, 1993; Groshens and Orth, 1993; P.G.& E., 1994) and it is widely recommended that HSC be developed for each site (Moyle and Baltz, 1985; Groshens and Orth, 1993; Glozier et al., 1997). Therefore, approaches are being sought to extend IFIM to whole fish communities in an ecologically meaningful way, i.e., without transferring HSC from other sites, while maintaining or reducing costs of instream flow analysis.

A methodology for grouping fishes into just a few habitat types would facilitate instream flow analysis in warmwater streams; habitat guilds have been proposed as one solution (Leonard and Orth, 1988). A guild is a set of organisms, regardless of taxonomic composition, that consumes the same class of environmental resources (Fauth et al., 1996). Therefore a fish-habitat guild consist of fishes, regardless of phylogenetic relationships, that use similar habitat. Up to

seven habitat guilds have been identified for fishes in studies of streams in Virginia, Minnesota, Alabama and New Zealand, with most approaches having four to six guilds (Bain et al., 1988; Lobb and Orth, 1991; Aadland, 1993; Vadas and Orth, 1997). Although the habitat guild approach facilitates flow-habitat analysis, it still requires prior knowledge of species' habitat. Before the species can be identified with a habitat guild, its habitat use must be known. Developing a method of identifying habitat guild membership for unclassified species will be critical to widespread application of guild approaches in instream flow assessment.

Habitat selection by fishes can be influenced by a variety of factors operating simultaneously at different spatial scales, including physiological-chemical, life-history, hydraulic, trophic, and biotic factors (Matthews, 1998). Factors influencing habitat selection may be placed in a hierarchical context of filters acting to determine usable habitat at a given time, e.g., habitat template theory (Figure 1.1). Filters operating at larger spatial scales are considered first followed by filters influencing habitat selection at successively smaller scales (Tonn et al., 1990; Poff, 1997). In rivers, physiological-chemical factors (pH, temperature, conductivity, dissolved oxygen) and life-history needs usually impact fish distributions at the watershed or stream reach scale (Allan, 1995). For example, fish assemblages in cold-water streams are different from those of warm-water streams, based on their tolerance to peak water temperatures (Allan, 1995). Individual fish then select their habitat based on life-history needs. Spawning of fishes is often associated with short or long migrations which impact habitat selection. Finally, fish select their local habitat based on hydraulic, trophic, and biotic factors that best match their current needs. Simple hydraulic conditions include depth, water velocity, substrate, and available cover and hydraulic factors describing more complex flow conditions include Reynolds number, Froude number, shear stress, and velocity gradients (Gordon et al., 1992; Vogel, 1994; Crowder and Diplas, 2000). Trophic factors include feeding ability and prey availability, and biotic factors include predators, competitors, symbiotic species and parasites (Matthews, 1998). On a daily or weekly basis, fish select habitat based on factors at the smaller scales while seasonally or annually extensive habitat shifts may be based on factors at the larger scales. Therefore, biological traits that interact with factors influencing habitat selection at smaller scales would provide the best chance for identifying usable habitat, i.e., guild membership, of a species during particular life

history stages and seasons; fish morphology is such a trait (Figure 1.1).

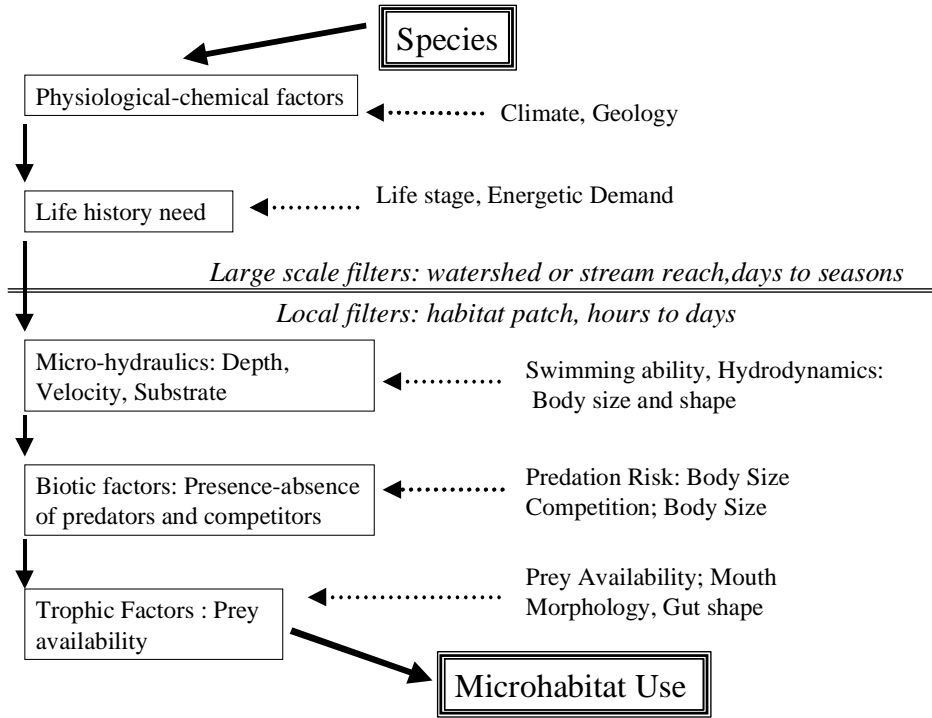

Figure 1.1. A hierarchy of environmental filters influencing habitat use of fish species at the local scale. Interactions of morphology and habitat filters at the local scale are shown to the right of filters.

Fish morphology constrains the ability of species to use habitat with specific hydraulic, trophic and biotic criteria. Body size, shape and subsequent hydrodynamics influence swimming ability of fishes (Videler and Wardle, 1991; Videler 1993), which determines what stream patches are hydraulically suitable for a species or individual. Further, feeding ability is related to mouth morphology or jaw strength (Wainwright, 1991; Nilsson and Broenmark, 2000) and body size may influence predation risk (Johnsson, 1993) and competitive ability (Fausch, 1988; Nakano et al., 1998). Therefore, a defensible method of predicting habitat use may be derived from a mechanistic approach to fish ecology using morphology (Schoener, 1986), an ecomorphological

approach.

Ecomorphology is the study of relationships of form and environmental factors (Motta et al., 1995b). Such approaches have been successful in understanding resource use at the individual level of many species because the morphology of organisms are related to their habitat through function, including fishes (Aleev, 1969; Gatz, 1979a,b; Webb, 1984), bats (Saunders and Barclay, 1992; Brigham et al., 1997), birds (Ricklefs and Travis, 1980; Leisler and Winkler, 1985), lizards (Moermond 1979, 1986), insects (Harder, 1985; Moran, 1986) and intertidal organisms such as algae (Denny, 1994). More recently attempts have been made to use morphology to predict habitat use, as opposed to trophic resource use.

Motta and Kotrschal (1992) suggest a stepwise approach to ecomorphology study, correlative, experimental, and comparatively evolutionary. The stepwise approach uses correlative study to provide working hypotheses of relationships between morphology traits and their use. The experimental phase then uses field or laboratory experiments (functional analysis) to determine the biological role and performance of a form-function alliance (Motta et al., 1995b). The third step allows formulation of evolutionary hypotheses and interpretation of contemporary patterns of resource use, i.e., separation of the effects of form and environment on each other (Figure 1.2). To make predictions of resource use with some level of certainty, only Step 1 and Step 2 need to be performed (Motta and Kotrschal, 1992). In this way, morphology limits the performance ability of a fish, e.g., through swimming or feeding ability, and therefore morphology constrains which environments a fish may use.

For warmwater fishes, correlative studies have been carried out for darters (Page and Swofford, 1984), cyprinids (Felley, 1984; Wood and Bain, 1995) and a variety of species (Gatz, 1979a,b). Within darters, traits that were related to habitat specialization included fusiformity, pigmentation, pre-maxillary protrusibility, snout shape, fin size (dorsal, pelvic and caudal peduncle), and loss of swimbladder (Page and Swofford, 1984). Within cyprinids intestine length, fin size (dorsal, pelvic fin and caudal peduncle), size of specific brain structures, scale size, pigmentation (lateral stripe length, peritoneum), and eye size were related to habitat features (Felley, 1984). Gatz (1979b) used correlation and factor analysis to suggest explanations for morphological variation associated with ecology of fishes. Significant factors that differentiated

fish based on ecology included technique of predation, maneuverability and utilization of habitats, and vertical partitioning (Gatz, 1979b). Feeding behavior accounted for 31% of the variance in character association. Habitat separation accounted for 12% of character variation (second factor).

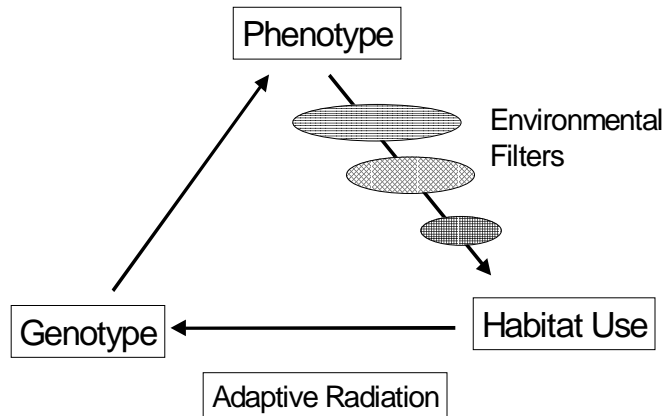

Figure 1.2. An illustration of the relationship of evolutionary history (genotype), phenotype (including morphology), and habitat use, including interaction of environmental filters. Habitat use influences morphology through evolution. Through comparative study, current resource use may be interpreted based on evolutionary histories of phenotypes.

The second factor separated pickerel-like morphology at one extreme and sunfish-like morphology at the other. The third factor identified characters associated with a benthic habitat and accounted for 10% of the variation in morphological characters. Gatz (1979a) concludes correlations between morphological traits suggest that they may be influenced by the same environmental factor and that a significant portion of a freshwater stream fishes' biology can be determined from its morphology. Results of Wood and Bain (1995) and Douglas and Matthews (1992) support this conclusion; morphology can predict habitat use and microhabitat and morphology co-vary, respectively.

Wood and Bain (1995) examined the relationships of microhabitat to morphological measurements of cyprinids, centrarchids, and percids using multivariate and univariate analysis. Five morphological measurements were important to associating microhabitat and cyprinid species: the position of the mouth, the position of the dorsal and anal fins relative to one another, and the position of the dorsal and anal fins relative to the body. Nine morphological measurements were necessary to describe darter morphology. On the first principal component axis, short, compact species were separated from long, narrow bodied species using six morphological measures. The second axis (five measures) described body compression about pectoral and pelvic fins, as well as a lengthening of the body shape. Centrarchid morphology measurements did not describe the microhabitat of centrarchid species. Wood and Bain (1995) suggested that the morphological measures they used were not adequate because they did not include measurements previously found to be significantly related to centrarchid habitat, and other researchers (Gatz, 1979a,b; Mittelbach, 1984) have found morphology-habitat relationships within the family.

As for the second step of the approach, there exists a large volume of literature that is devoted to swimming performance of fishes (Videler, 1993; Hammer, 1995; Triantafyllou et al., 2000). Most of this literature concentrates on the physiology of sustained swimming ability and is limited to a few species, especially salmonids, but the general effects of various environmental factors on swimming performance are fairly well described (Kolok, 1991; Hammer, 1995; Adams and Parsons, 1998). Some of the swimming performance literature does incorporate the interaction of morphology and shape (Webb, 1984; Videler and Wardle, 1991).

Aleev (1969) determined a trunk shape index that roughly measured the hydrodynamics of fish body shape. Fish with greater streamlining have enhanced swimming performance (Aleev, 1969; Videler and Wardle, 1991). Aleev (1969) also discussed morphology changes with ontogenetic development of fishes; ontogenetic changes are often associated with habitat shifts in many species of freshwater fishes (Werner and Hall, 1988). Webb (1984) found specific features of fish morphology were related to habitat. For example, fish successful in structurally complex environments tend to have laterally flattened bodies with an outline of a disk or diamond. These fish also require maneuvering ability within these environments and usually have a triangular

pectoral fin with the apex at the fin base. Webb (1984) described a functional-morphology pyramid of swimming ability with specialist forms for acceleration, cruising, and maneuvering as each corner. He concluded that most fish were generalists and that an optimum morphology design could not include all features for the different types of designs because gross morphology was an evolutionary result of environmental forces acting on the fish (Figure 1.2), including mode of swimming, amount of swimming, method of obtaining food, and mode of life (swimming may be secondary to other activities). However, Webb (1984) considered morphology and habitat on a broad scale and his results overlooked minor morphological variation which may have real consequences for adaptive dispersal of fishes.

Further, many species of fish have strong affinities for specific habitat types and lifestyles and show specialization within their habitat type, particularly for limited resources.

Results of Bandyopadhyay et al. (1997) further elaborate fish functional morphology relative to swimming ability. Fishes had trends in morphology for similar maneuverability; of fish with the same overall aspect ratio (fork length/body height), maneuverable, low-speed species exhibited fuller caudal fins than fast-swimming species. Therefore, morphology does serve to constrain performance of important, daily tasks of fishes.

In summary, there exists substantial evidence that morphology is correlated to the ecology of fishes and functional analysis of performance has predicted resource use in many situations. However, this work has not been applied to the ecomorphology and resource guilds of stream fishes. If habitat types or habitat guilds (Vadas and Orth, 2000) are truly “ecological units” and not just imposed resource groupings, they should also serve as “evolutionary units” (Liesler and Winkler, 1985), i.e., the morphology of phenotypes occupying those units may converge within habitat types.

Similar morphological adaptations have been identified in fishes utilizing comparable habitats or feeding strategies among very distantly related fishes of the world (Wikramanayake, 1990). Webb’s (1984) shape pyramid and Aleev’s (1969) study of functional swimming ability demonstrated that regardless of family (phylogenetic relationships), fishes with similar functional ability tend to have similar morphological adaptations. In stream fishes, convergent morphological adaptations among fish from different families have occurred within benthic or

pelagic groups of fishes. In both minnows and darters, those species that are pelagic tend to have more well developed swim bladders while those that are benthic have no or reduced swim bladders (Page and Swofford, 1984). Fishes sharing similar feeding strategies often develop similar morphology, such as the upturned snouts and flattened dorsal surfaces of surface feeders (Matthews 1998). Mayden (1989) identified convergent evolution as alternative explanation for the relationships among species of the genus *Hybopsis* (and related species). Mayden (1989) stated “this grouping may be artificial, due to possible convergent evolution of morphological characteristics for a similar benthic lifestyle.” These observations and others suggest that similar morphology may be common to species utilizing comparable habitat types or feeding strategies. Similarly, Page and Swofford (1984) noted that unrelated groups of darters using the same habitats have more similar morphology than closely related groups of darters using different habitats.

Therefore, in an attempt to improve procedures of instream flow analysis of diverse communities in warmwater streams, this study had the following three objectives: (1) determine if morphology could predict membership of fishes in habitat guilds of the Roanoke River (VA), (2) examine factors influencing prediction rates, and (3) test the transferability of morphological functions for predicting habitat use of fishes in a second watershed. To accomplish objective one, this study used two guild classification systems (described in detail in the methods) of three and seven habitat types for fishes of the upper Roanoke River (VA). I tested the following hypotheses: (1) prediction error will be lower in the seven-guild system because morphology-habitat relationships are likely to be closely matched in the more explicit system, (2) generalist guilds will have higher prediction error than non-generalist guilds, and (3) prediction error rates will be lower for guilds with more demanding physical environments, e.g., flowing water, where morphological adaptations are likely to limit habitat use. To accomplish objective two, statistical analysis was carried out to determine what factors influenced prediction rates by morphological functions, including analysis of sample sizes, presence/absence of a species, and fish collection site. Finally, I tested the transferability of the discriminant functions (objective three) by attempting to predict habitat use of 23 additional species, 21 species being from a second watershed (Powell River, VA).

Material and Methods

Guild Classification Systems

A habitat guild framework allows *a priori* classification of stream fishes for statistical testing of morphological differences. Vadas and Orth (1997, 2000) collected fishes in microhabitat quadrants over two years, during warmer seasons at six stations in the upper Roanoke River, VA. Stations had channel thalweg lengths of 460-655 m. Before sampling, mesohabitat units were established visually using five categories (medium pool, shallow pool, run, slow riffle, fast riffle) and then mesohabitat units were sampled proportional to their abundance.

Fish and microhabitat samples were taken within mesohabitat units using quadrats that were approximately 20-50 m² in surface area. Fish species (all life stages except fry) were sampled with a seine net or electrofishing (stream side generator) above a block net. Species densities were used to establish fish-habitat relationships and habitat-use guilds. Quadrat size varied with the homogeneity of hydraulic and channel roughness characteristics; quadrats taken in rapidly varying areas such as riffles had smaller areas and those in more uniform sections such as pools employed larger areas. Each station had 42-80 quadrat samples, which sampled approximately 20% of the area of each mesohabitat unit at a station.

Within each quadrat, depth, demersal velocity, and water-column velocity, and substrata (nine categories) were measured at three locations along a diagonal from one corner to another (Vadas and Orth 1997). Average substratum size was determined using the first, second, and third most frequent substratum types (Vadas and Orth 1997). Percent of instream cover was also recorded relative to quadrat surface area. From measured habitat conditions, additional complex hydraulic variables were calculated including Reynolds number (water-column turbulence), Froude number (surface turbulence), and boundary Reynolds number (bottom turbulence) (Vadas and Orth 1997). The twelve physical variables used in their statistical analysis were depth, average velocity (0.6 depth), demersal velocity (4.5 cm from bottom), percent of mud and sand (fines), percent boulders and bedrock (large rocks), average substratum size, percent cover, velocity shelter (average velocity – demersal velocity), Reynolds number (water-column turbulence), Froude number (surface turbulence), boundary Reynolds number (bottom turbulence), and the ratio of average velocity to depth.

For statistical analysis, uni-, bi-, and multi-variate statistics were considered in developing species associations and fish-habitat relationships (Vadas and Orth 1997). Mesohabitat assignments made prior to sampling quadrats were used to test fish-habitat associations using aggregated (quadrats pooled by mesohabitat units) and un-aggregated (un-pooled quadrats) samples (Vadas and Orth 1997). For example, they whether or not species were using different mesohabitat types (a pool-run or riffle species) or if species were using all types similarly (generalists).

Upon full analysis of habitat characteristics and species densities, Vadas and Orth (1997) established that un-aggregated data analysis (not-pooled by mesohabitat unit) provided only three categories of habitat use, rheophilic (flow-loving), limnophilic (slow-moving water) and generalists. Aggregated data analysis provided a seven-guild classification system, four rheophilic groups (fast-riffle, riffle-run, shallow-rheophilic, fast-generalists) and three limnophilic groups (pool-open, pool-cover, pool-run). This study employed both the seven (microhabitat) and three (mesohabitat) guild systems of Vadas and Orth (1997, 2000) for testing hypotheses of microhabitat/mesohabitat and morphological relationships (Table 1.1).

Fish collection

Adult fishes were collected from the North and South Fork of the Roanoke River, with a backpack electrofishing unit, anaesthetized with Tricaine methanesulfonate, and then preserved in 10% formalin. For large fishes, greater than 200 mm total length, the abdominal cavity was sliced open to allow penetration of formalin. Fishes remained in formalin for at least five days, washed in water for five days and were then transferred to 50% ethanol for storage.

Table 1.1. Fish species and sample sizes used in this study listed by microhabitat and mesohabitat guild classification (Vadas and Orth, 2000).

Guild	Common Name	Species	Sample Size
<u>Microhabitat Framework</u>			
Fast-Riffle	Torrent sucker	<i>Thoburnia rhothoeca</i>	34
	Roanoke darter	<i>Percina roanoka</i>	9
Riffle-Run	Mottled Sculpin	<i>Cottus bairdi</i>	28
	Fantail darter	<i>Etheostoma flabellare</i>	60
	Riverweed darter	<i>Etheostoma podostemone</i>	37
	Central stoneroller	<i>Campostoma anomalum</i>	17
Fast-Generalist	Roanoke hog sucker	<i>Hypentelium roanokense</i>	17
	Margined madtom	<i>Noturus insignis</i>	21
	Black jumprock	<i>Scartomyzon cervinus</i>	25
	Bluehead chub	<i>Nocomis leptocephalus</i>	31
Shallow-Rheophilic	Mt. redbelly dace	<i>Phoxinus oreas</i>	43
	East. blacknose dace	<i>Rhinichthys atratulus atratulus</i>	45
Pool-Run	Crescent shiner	<i>Luxilus cerasinus</i>	37
	White shiner	<i>Luxilus albeolus</i>	23
	White sucker	<i>Catostomus commersoni</i>	26
Pool-Open	Mimic shiner	<i>Notropis volucellus</i>	12
	Swallowtail shiner	<i>Notropis procne</i>	14
Pool-Covered	Bluntnose minnow	<i>Pimephales notatus</i>	12
	Spottail shiner	<i>Notropis hudsonius</i>	16
	Redbreast sunfish	<i>Lepomis auritus</i>	6
	Northern hog sucker	<i>Hypentelium nigricans</i>	7
	Golden redhorse	<i>Moxostoma erythrurum</i>	2
	Silver redhorse	<i>Moxostoma antiserum</i>	4

Table 1.1 *continued.*

Guild	Common Name	Species	Sample Size
<u>Mesohabitat Framework</u>			
Rheophilic	Torrent sucker	<i>Thoburnia rathoeca</i>	34
	Roanoke darter	<i>Percina roanoka</i>	9
	Mottled Sculpin	<i>Cottus bairdi</i>	28
	Fantail darter	<i>Etheostoma flabellare</i>	60
	Riverweed darter	<i>Etheostoma podostemone</i>	37
	Central stoneroller	<i>Campostoma anomalum</i>	17
Generalists	Roanoke hog sucker	<i>Hypentelium roanokense</i>	17
	Margined madtom	<i>Noturus insignis</i>	21
	Black jumprock	<i>Scartomyzon cervinus</i>	25
	Mt. redbelly dace	<i>Phoxinus oreas</i>	43
	East. blacknose dace	<i>Rhinichthys atratulus atratulus</i>	45
	Crescent shiner	<i>Luxilus cerasinus</i>	37
	White sucker	<i>Catostomus commersoni</i>	26
	Bluntnose minnow	<i>Pimephales notatus</i>	12
	Spottail shiner	<i>Notropis hudsonius</i>	16
Limnophilic	Bluehead chub	<i>Nocomis leptcephalus</i>	31
	Redbreast sunfish	<i>Lepomis auritus</i>	6
	Mimic shiner	<i>Notropis volucellus</i>	12
	Swallowtail shiner	<i>Notropis procne</i>	14
	White shiner	<i>Luxilus albeolus</i>	23

Morphology measurements

Thirty morphological characteristics related to habitat were identified from the literature. Trait measurements (Appendix A) were made on each adult fish using digital calipers to the nearest 0.1 mm except for traits more than 155 mm in length which were measured with metal rulers to the nearest 1 mm. Only adult fishes were used because fish morphology changes with development and changes are associated with shifts in habitat use (Sagnes et al., 1997). An attempt was made to measure ten individuals of each species and at least three species per guild. Initial measurements of morphology were either standardized to body size (standard length) or

used to calculate new shape indices (Appendix A) to create a set of 40 shape variables for analysis.

Statistical Software

All analysis procedures were carried out using Statistical Analysis Software (vers. 7.0, Statistical Analysis Systems Institute, Inc., Cary, NC, unpubl.). Plots were created in SYSTAT (vers. 8.0, SPSS, Inc., Chicago, IL, unpubl.).

Preliminary Analysis

To explore the data, univariate box plots were constructed of each morphological trait plotted by species and outliers were assessed. Each suspect observation, those observations outside of three interquartile ranges and those approximately one half to double the typical value for a species were examined. Outliers were observations with values more than one half or double the typical value for similarly sized conspecifics (e.g., an outlier would be a fish having a recorded fin length more than twice that of similar size members of its genus while having similar trait sizes for other measurements of the same body area). Because tags used to mark individual fish deteriorated in storage, measurements could not be corrected on most individuals. Therefore, these individuals were removed before further analysis with the exception of those traits that were related to fin characteristics. Fins often preserved in different states of expression. Inducing partially open fins to a state of full expression was difficult. Because this difficulty added variation to the data and removing suspect observations of all fins might severely limit the overall sample size, fin measurements were not used as a criteria for removal.

Correlation analysis was performed to remove variables with redundant information about fish body shape. For each pair with a Pearson correlation coefficient of 0.9 or higher, one variable was removed. Because the analysis was meant to remove only those variables that were highly correlated, only traits with coefficients of greater than 0.9 were removed. In multivariate analysis correlated variables might still contribute separately to classification of species through interactions with other variables. Therefore, a high coefficient was used in order to be conservative about removing potential multivariate shape information.

Next, principal component analysis (no rotation) using all morphological traits was performed using their correlation matrix to examine data structure in multivariate space. Plots of components were made to examine structure and look for observations appearing as outliers, i.e., observations of a species occupying a section of multivariate space that was unusual for other observations of the same species.

Univariate Analysis

An unbalanced ANOVA was used to test whether significant differences existed among guilds (both seven and three-guild systems) at the univariate level for each of the 30 morphological traits. Both the microhabitat and mesohabitat guild frameworks were tested. The analysis was performed using the GLM procedure with a Student-Newman-Keuls multiple range test on means because it controls experiment-wise error.

Multivariate Analysis

For both guild frameworks, stepwise discriminant analysis was performed to identify those variables that contributed to classification of species into guilds. The number of variables included is dependent on significance levels to enter and stay, set in the stepwise discriminant analysis. An analysis of the significance level and the number of variables selected was performed with the microhabitat guild framework in an attempt to keep the model from being over specified. Prior probabilities were assigned proportionally between guilds. Finally, discriminant analysis was used to create a set of discriminate functions, i.e., hereto referenced as the model, for scoring individuals by guild. Prior probabilities of assignment were set at equal probability for all guilds. Multivariate normality was assumed due to a lack of strong analytical techniques for detecting non-normality (B. Noble, personal communication). Further, all measurements used in analysis were transformed to ratios by combining them with other variables or standardizing them to fish standard length.

Expected error rates of misclassification (posterior misclassification rates) were estimated using Lachenbruch's holdout procedure. For this study, success in classifying species in holdout tests and transferability tests was judged according to a "majority rule." If morphology correctly

classified the majority (>50%) of individuals of a species into the habitat guild as determined by habitat assessment, then species as a whole were considered to be correctly classified. For some tests of factors influencing classification, species were not considered. Rather, the percent of individuals correctly classified was used for comparisons.

Testing Factors Influencing Classification Rates

In order to understand what factors may have influenced classification error and success, I performed analysis of the effect of presence/absence of species, removing poorly classifying guilds, sample size, and sample location on classification success using holdout procedures.

Removing Individual Species Before Variable Selection

To test the robustness of the set of shape variables identified as important for guild separation, I carried out further analysis. To determine if trait selection was stable, i.e., the number of variables and the selection of variables are independent of species used in the model), species were removed one at a time and the multivariate analysis repeated. The overall misclassification rates of the modified models (functions) were compared to the same rate for the model with all 23 species.

Removing Individual Species Immediately Before Discriminant Function Construction

To test the predictive ability of shape variables selected for separating guilds when using all species, each species was withheld one at a time during discriminant function construction, but always using the same set of morphological variables. Models then were used to classify individuals of the removed species.

Removing Guilds with Poor Classification

Guilds that experienced relatively high misclassification rates (>20%) were removed, one at a time, and changes in error rates of remaining guilds were examined relative to the model with all guilds.

Effect of Data Set Size on Classification Rates

Sample size of the entire data set was analyzed for effect on guild and overall posterior classification error. To examine the effect of data set size on misclassification rates, 10%, 25%, or 50% of all observations (individuals) were randomly removed and then discriminant analysis was performed, using the original variables of the model. Prior probabilities of assignment were set at equal probability for all guilds. The removed observations were kept as a validation data set and misclassification of the set was examined. This process was repeated 50 times for each treatment and average misclassification rates were compared for guilds and the overall model by treatment.

Effect of Sample Size of Species on Same Species Classification

To test sample size of species on their misclassification rates, sample sizes for individual species were altered before discriminant analysis for six species. The first treatment (a small sample) was to randomly select five individuals of a species, run discriminant analysis, and then use remaining individuals per species as a validation data set. The second treatment (a large sample) used 20 individuals per species to construct the model and the remaining individuals for testing. Each treatment was executed 50 times for six different species.

Effect of Collection Site on Species Classification Error

When testing species misclassification rates, the collection site was also considered. For six species, a model was constructed (discriminant analysis, using same shape variables) with all individuals from one site representing a species and then classification error of individuals of the same species from remaining sites were examined.

Transferability of Morphological Functions

Two data sets were assembled to test the ability of produced discriminant functions to predict habitat, including a set of 17 common minnows and darters from the Powell River system, and a set of eight fishes listed as either threatened or endangered, in Virginia (Table 1.2).

Table 1.2. Species in each of two data sets used to test the transferability of morphology traits for identification of habitat guilds. *A priori* (before testing) guild assignments are given, acronyms are as follows: FG=fast-generalist, FR=fast-riffle, PC=pool-covered, PO=pool open, PR=pool-run, RR=riffle-run, and SR=shallow-rheophilic. Species of the Virginia T&E data are listed as threatened or endangered in Virginia. Fishes of the Powell River are also from Virginia.

Data Set	Species	Common Name	Guild
Virginia T&E	<i>Notropis alborus</i>	Whitemouth shiner	PO
Virginia T&E	<i>Etheostoma acuticeps</i>	Sharphead darter	RR
Virginia T&E	<i>Phoxinus tennesseensis</i>	Tennessee dace	SR
Virginia T&E	<i>Cyprinella whipplei</i>	Steelcolor shiner	PR
Virginia T&E	<i>Erimystax cahni</i>	Slender chub	FG
Virginia T&E	<i>Percina rex</i>	Roanoke log perch	FG
Virginia T&E	<i>Noturus gilberti</i>	Orange-fin madtom	FR
Virginia T&E	<i>Cyprinella monocha</i>	Spotfin chub	RR
Powell River	<i>Erimystax insignis</i>	Blotched chub	RR
Powell River	<i>Rhinichthys atratulus obtusus</i>	Blacknose Dace	SR
Powell River	<i>Etheostoma zonale</i>	Banded Darter	RR
Powell River	<i>Hybopsis amblops</i>	Bigeye chub	PC
Powell River	<i>Percina evides</i>	Guilt Darter	RR
Powell River	<i>Etheostoma blennioides</i>	Greenside darter	RR
Powell River	<i>Etheostoma rufilineatum</i>	Redline darter	RR
Powell River	<i>Nocomis micropogon</i>	River chub	PC
Powell River	<i>Etheostoma simoterum</i>	Snubnose darter	SR
Powell River	<i>Campostoma anomalum</i>	Central stoneroller	RR
Powell River	<i>Luxilus chrysocephalus</i>	Striped shiner	FG
Powell River	<i>Phenacobius uranops</i>	Stargazing minnow	RR
Powell River	<i>Notropis telescopus</i>	Telescope shiner	PC
Powell River	<i>Percina aurantiaca</i>	Tangerine darter	RR
Powell River	<i>Notropis leuciodus</i>	Tennessee shiner	RR
Powell River	<i>Luxilus coccogenis</i>	Warpaint shiner	FG
Powell River	<i>Cyprinella galactura</i>	Whitetail shiner	PC

Threatened and endangered fishes were obtained from museum specimens at Roanoke College (R. Jenkins, personal communication) and fishes of the Powell River were collected with backpack electrofishing and preserved using the same methodology used for fishes of the Roanoke River. Because specimen condition was important for future studies of the threatened or endangered fishes, specimens were handled once in this study and returned to the museum. Therefore,

specimens with at least one outlying measurement were removed from further analysis rather than attempting to correct questionable measurements discovered during box plot inspection.

Species from both data sets were assigned to one of the seven microhabitat guilds based on habitat use reported in the literature (Table 1.2). For Virginia threatened and endangered species, habitat was assigned based on qualitative descriptions by Terwilliger et al. (1995) and Jenkins and Burkhead (1994) and quantitative information for *Percina rex* (Vadas and Orth, 1997, 2000) and *Noturus gilberti* (Vadas and Orth 2000; Simonson and Neves, 1992). Powell River fishes were assigned guilds based on microhabitat data from Temple (1997) combined with qualitative descriptions by Jenkins and Burkhead (1994). Temple (1997) sampled microhabitat of fishes using 4 m x 2 m electrofishing grids, four grids per transect, and six transects per site. Riffle, runs, and "head runs" were sampled with grids. Microhabitat (water depth and velocity) was sampled at the four corners of the grids.

In order to classify species to guilds *a priori* for comparisons with results of morphological predictions, habitat criteria were established for guilds of the Roanoke River (Table 1.3). Criteria were derived by examining figures of habitat use (Vadas and Orth, 2000) which report the range of habitat means used by each species. Criteria for specific guilds were based on these data for all species within a guild and assigned because they encompassed both the majority of overlapping habitat used by all species within the guild and contained the mid-point of the range of habitat used by all species. Based on recorded habitat measurements found in the literature, species were then assigned to a habitat guild. If habitat use by a species matched criteria for more than one guild, I used qualitative descriptions of habitat type and expert opinion to make final assignments.

Table 1.3. In order to classify species to habitat guilds *a priori* for comparisons with results of morphology predictions, habitat thresholds for guilds of the Roanoke River were established. Criteria were derived by examining figures of habitat use (Vadas and Orth, 2000), which report the range of mean habitat used by each species for each variable. Criteria for each guild were based on this data for all species within the guild and were assigned because they encompassed both the majority of overlapping habitat used by species and contained the mid-point of the range of habitat for all species.

Guild	Depth (cm) (m)	Velocity (cm/s) (m/s)	Froude (#) (#)	Substrate (Size)
Fast-generalist	0.2-0.45	0.2-0.4	0.04-0.20	Gravel through cobble
Fast-riffle	0.15-0.35	0.35-0.70	0.1-0.47	Gravel through cobble
Pool-covered	> 0.3	< 0.5	0.01-0.17	Small gravel to small boulder, more fine substrate
Pool-open	> 0.3	0.1-0.35	0.01-0.11	Small gravel to large cobble, less fine substrate
Pool-run	> 0.2	0.1-0.45	0.01-0.22	Gravel to cobble
Riffle-run	0.15-0.3	0.1-0.75	0.03-0.50	Gravel to cobble,
Shallow-rheophilic	< 0.35	0.2-0.45	0.05-0.45	Small cobble

The DISCRIM procedure was then used to place each individual from all species into one of the seven microhabitat guilds based on the morphological functions derived using fishes of the Roanoke River. Prior probability levels were assigned as equal (instead of proportional). Comparison of the morphology and habitat assigned guilds were then made. Habitat predictions for species were judged to be successful using a majority rule (see *Multivariate Analysis* above for details).

Results

Measurements from adults of 23 species, representing six families and 18 genera, were collected for analysis. The species collected were inclusive of all seven microhabitat guilds (and all three mesohabitat guilds) of Vadas and Orth (1997) and each guild was represented by at least two species. There were 588 individuals measured. It took from 10-15 min to measure all traits on an individual fish.

Preliminary Analysis

Box plots were used to examine the data for outliers. Sixty-two fish were removed because they had at least one questionable trait measurement and the remaining 526 used in analysis. Box plots for each trait by species of all data used in analysis are given in Appendix B.

Correlation analysis revealed three pairs of variables with coefficients greater than 0.9. The three pairs were maximum body depth and distance from dorsal fin to pelvic fin, two different methods of calculating the caudal fin aspect ratio, and the distances from pectoral to pelvic fin and from neurocranium to pelvic fin. The dorsal fin to pelvic fin measurement, the second caudal fin aspect ratio variable, and the measurement from neurocranium to pelvic fin were removed from further analysis. The correlation coefficients are given in Appendix C.

From the principal component analysis there were nine eigenvectors with eigenvalues greater than one. These components accounted for 83% of the maximum variation in the data. The first principal component accounted for 24% of the variation in the data. The second and third components accounted for an additional 17% and 13% of the variation. For details of the other components and additional plots of principal components see Appendix D.

Traits that loaded heavily (in top three of traits based on absolute factor loadings) for all nine eigenvectors were: distance from dorsal fin to anal fin, caudal fin aspect ratio, ratio of caudal fin depth to maximum body depth, caudal fin length, caudal peduncle depth, caudal peduncle compression index, caudal peduncle length, caudal peduncle width, ratio of eye size to head depth, head depth, distance from jaw to pectoral fin, maximum body depth, maximum body width, maximum dorsal fin span, dorsal fin span relative to body depth, the size of the pectoral fin, distance from pectoral fin to pelvic fin, pectoral fin width, distance from neurocranium to pectoral

fin, dorsal fin length, trunk shape, and height of the caudal fin where it inserts into the caudal peduncle. After the third highest loaded factor, loadings typically dropped in value for most eigenvectors, indicating a break in importance for other factors. In biological terms, when several traits load on the same principal component, it means that those traits account for the variation described by the component. Higher loadings for a trait indicate more of the variation is explained by that trait.

On the first component (PRIN1), dorsal fin length, distance between pectoral and pelvic fin decreased, and position of the dorsal fin loaded most heavily. Component one ordinated fish morphology associated along an axis of mesohabitat types (Gatz, 1979a). For example, darters which generally occupy riffles scored high on PRIN1, having long dorsal fins, flattened bodies with pectoral fins positioned low (less distance from pectoral to pelvic fin) on the side of the body and short heads. Fishes scoring low on PRIN1 were more pool species, like centrarchids, redhorse and some suckers (Vadas and Orth 2000). Centrarchids have platter shaped bodies (more distance between pectoral and pelvic fins), less dorsal fin length, and relatively longer heads (meaning the dorsal fin is not as forward) (Webb, 1984). Redhorse and suckers had shorter dorsal fins, pectorals more positioned on the body sides, and a much longer stretch of the body ahead of the dorsal fin (long head).

The second component (PRIN2) represented a shift from more benthic fishes (low scores) to more open-water species (high scores). Fishes scoring high on PRIN2 had larger eyes (sight is important to drift feeding fishes typical of open-water), decreased pectoral fin area (more slender, agile fins), and high caudal fin aspect ratios (more lunate like tails). Fishes scoring in the center of the component tended to be benthic with smaller eyes relative to head depth but increased pectoral fin area and lower caudal fin aspect ratios (more squared tails). Fishes scoring low on PRIN2 were small-eyed relative to head depth such as suckers and catfish which were benthic feeders of detritus or feed at night. Both suckers and catfish have a highly-developed sense of tastes, suckers in their lips and catfish in their barbels, and can rely less on sight for feeding.

Plots of the first and second principal components (Figure 1.3) revealed that the riffle-run guild and some observations of the fast-riffle guild (belonging to *Percina roanoka*) form a grouping well apart from the other guilds along the first component. On the second component,

the pool-open, shallow-rheophilic, and pool-run guilds formed a cluster on the positive end of the axis, opposite the fast-generalist, fast-riffle, and pool-covered guilds. Some observations of the pool-run (belonging to *Catostomus commersoni*) and riffle-run (belonging to *Campostoma anomalum*) guild occurred with the fast-generalist/fast-riffle cluster. A few observations of the pool-covered guild (belong to *Notropis hudsonius*) occupied space at the positive side of the second component with the pool-open and shallow-rheophilic guild. Observations of redbreast sunfish, *Lepomis auritus*, of the pool-covered guild were away from other members of its guild, plotting with *Noturus insignis*, a fast-generalist which represented the extreme edge of its cluster when plotted on component one. In other plots, these two species would again plot away from other members of their habitat guild and often in areas by themselves (see plots in Appendix D). Plotting by guild on other principal components did not reveal distinct patterns based on habitat use, generally slow-moving water habitat types grouped together away from flowing water habitat types with redbreast sunfish and margined madtom plotting away from the core clusters. In summary, principal components analysis of morphological traits only identified the coarsest level of habitat use (pool dwellers versus riffle dwellers) among fishes of the Roanoke River and was not sufficient to identify habitat guilds based on variation of the data set.

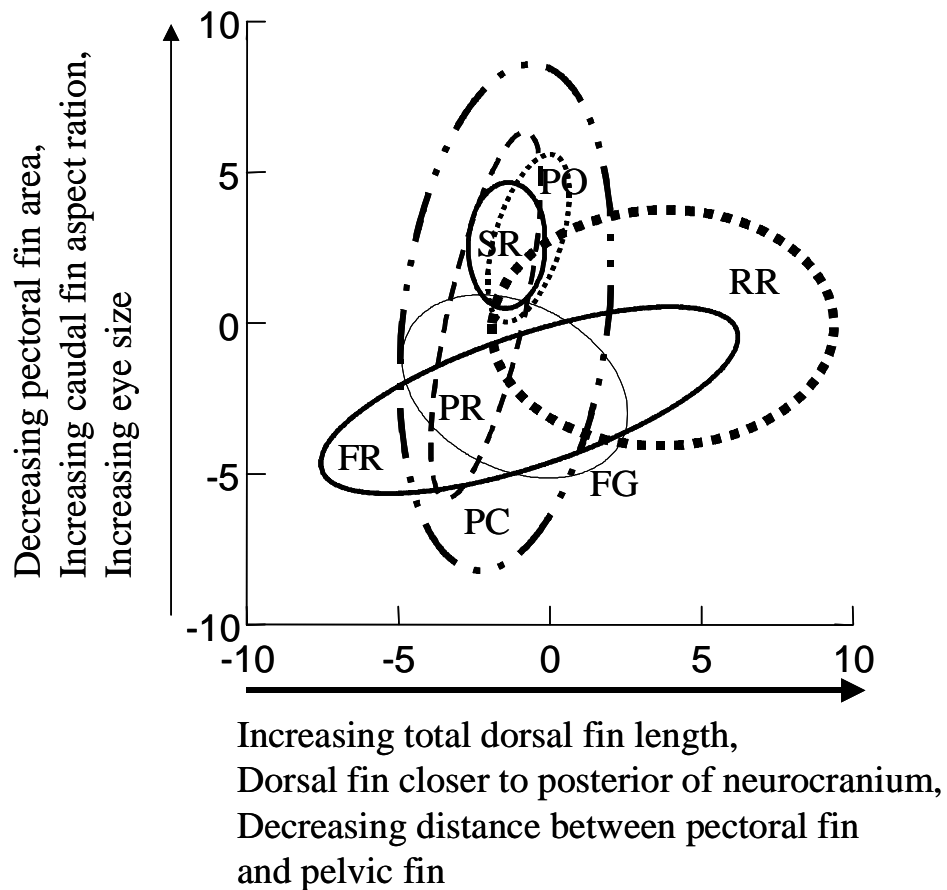

Figure 1.3. Plot of microhabitat guilds as 95% confidence ellipses around samples on the first (abscissa) and second principal components (ordinate). Guild acronyms are as follows: FG=fast-generalist, FR=fast-riffle, PC=pool-covered, PO=pool open, PR=pool-run, RR=riffle-run, and SR=shallow-rheophilic.

Univariate Analysis

For the microhabitat guild framework, six traits were significantly different among guilds at the $p < 0.05$ level (Table 1.4); the six traits were axial caudal fin length, dorsal fin length, caudal fin depth, pectoral fin length, lateral position of the eye, and distance from pelvic to anal fin (mid-body length). However, at its best, univariate separation by a single trait identified only two groups and none of the seven microhabitat guilds, distinctly.

Table 1.4. Results of unbalanced ANOVA tests of trait means among microhabitat guilds. Tests that were significant at $p < 0.05$ are in bold lettering and include axial caudal fin length (ACFL), caudal fin depth (CFD), total length of dorsal fins (TLDF), pectoral fin length (PFL), eye location (EYELOC), and distance from pelvic to anal fin (PELAF). Measurements are illustrated in Appendix A.

Variable	p-value	Variable	p-value
ACFL	0.015	CFL	0.506
CFD	0.036	EYESIZHD	0.265
MBD	0.835	CFDMBD	0.624
TLDF	0.050	MBDMBW	0.321
MDFS	0.097	CFAREA	0.149
MDFSMBD	0.257	CFASP	0.715
MBW	0.721	CFASP22	0.110
CPD	0.950	ADFAF	0.182
CPW	0.368	PDFAF	0.792
HD	0.853	JMAX	0.924
TRUNK	0.249	PNERDF	0.056
PFW	0.311	AFVMCF	0.056
PFL	0.045	VMCFDMCF	0.924
PECAREA	0.429	PNERPEC	0.490
PECASP	0.225	MAXPEC	0.779
EYELOC	0.017	PELAF	0.044
PECPEL	0.116	CPINDEX	0.406
EYESIZ	0.465		
CPL	0.585		

For the mesohabitat guild framework, ANOVAs for caudal fin depth, dorsal fin length, pectoral fin width and length, distance from pectoral to pelvic fin, position of the dorsal fin (back from head), distance from anal fin to caudal fin and pelvic to anal fin length were significant at the $p < 0.05$ level (Table 1.5). However, no single trait was able to separate all guilds. For traits with statistically significant differences (based on ANOVA analysis), differences in mean guild separation were plotted for both the microhabitat and mesohabitat guild frameworks in Appendix E.

Table 1.5. Results of unbalanced ANOVA tests of trait means among mesohabitat guilds. Tests that were significant at $p < 0.05$ are in bold lettering and include caudal fin depth (CFD), total length of dorsal fins (TLDF), pectoral fin length (PFL), distance from pectoral fin to pelvic fin (PECPEL), distance from posterior of neurocranium to dorsal fin (PNERDF), distance from anal fin to ventral membrane of caudal fin (AFVMCF), and distance from pelvic fin to anal fin (PELAF). Measurements are illustrated in Appendix A.

Variable	p-value	Variable	p-value
ACFL	0.860	CFL	0.301
CFD	0.029	EYESIZHD	0.716
MBD	0.055	CFDMBD	0.062
TLDF	0.006	MBDMBW	0.069
MDFS	0.458	CFAREA	0.096
MDFSMBD	0.130	CFASP	0.292
MBW	0.886	CFASP22	0.718
CPD	0.746	ADFAF	0.542
CPW	0.156	PDFAF	0.541
HD	0.260	JMAX2	0.253
TRUNK	0.104	PNERDF	0.011
PFW	0.027	AFVMCF	0.039
PFL	0.005	PNERPEC	0.115
PECAREA	0.500	VMCFDMCF	0.638
PECASP	0.518	MAXPEC	0.901
EYELOC	0.226	PELAF	0.003
PECPEL	0.026	CPINDEX	0.710
EYESIZ2	0.127		
CPL2	0.241		

In general, results of the ANOVA tests were similar for both the seven-guild and three-guild systems. Individual traits were able to identify very coarse habitat separation, guilds with fast-flowing water (riffle and fast-generalists) from guilds of slow-moving water (pools and runs). In the three-guild system, several traits separated the rheophilic guild from the other two guilds (limnophilic, generalists). Most of the traits identified at this level are related to swimming ability, suggesting that at a coarse level, swimming performance will identify some aspects of usable habitat.

Multivariate Analysis

Stepwise discriminant analysis identified variables important to modeling separation of the seven microhabitat and three mesohabitat guilds. When the significance levels for variables to enter and to stay were set at 0.05, 34 variables were selected with a 11.0% overall posterior misclassification rate for the microhabitat guilds. As the significance level was lowered, the number of variables selected for the model decreased, but the overall misclassification rate increased (Figure 1.4). By setting significance level at 1E-11, the number of variables in the model was reduced 56%, to 15, while the overall error remained below 20%, rising only 6.2 percentage points to 17.2%. Raising the significance level further (to 1E-013 and above) raised the overall error rate nearly four points, above 20%, but did not reduce the number of variables proportional to the increase in error.

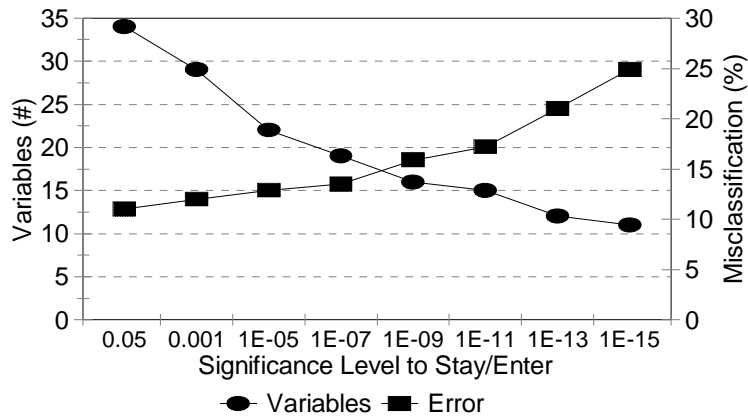

Figure 1.4. The effect of changing the significance level for variables to stay and enter on the number of variables selected by stepwise discriminant analysis. The trade off among the number of variables in the model and holdout test misclassification rate was used to determine the number of variables to keep in the model.

Reducing the number of variables in the model to a minimum was important for identifying shape characteristics to separate the guilds. Including many variables in the model would artificially lower error rates in holdout tests, simply because the model can account for more of

the variation in the data among guilds. Using a smaller set of more important variables advances our understanding of morphological factors potentially driving habitat separation. Further, by using very small significance levels to identify the most important variables for guild identification, the effect of multiple tests was better controlled. Therefore, I used the model with 15 variables, listed in Table 1.6, for further analysis. Using the same significance level for the mesohabitat guild framework produced three variables important for separating guilds: dorsal fin length, maximum body depth, and caudal fin length. Discriminant functions for the seven-guild system are given in Table 1.7 and those for the three-guild system are in Table 1.8.

Table 1.6. The fifteen shape variables selected from all variables examined and used in discriminant functions.

Variable	Description (all relative to standard length)
ACFL	Axial caudal fin length
ADFAF	Distance from anterior of dorsal fin to anal fin
CFAREA	Caudal fin area
CPD	Caudal peduncle depth
EYESIZHD	Eye size relative to head depth
HD	Head depth
MAXPEC	Distance from posterior of maxillary to anterior of pectoral fin
MBDMBW	Ratio of maximum body depth to width
MDFS	Maximum dorsal fin span
PECAREA	Size of the pectoral fin
PELAF	Distance from pelvic fin to anal fin
PFL	Pectoral fin length
PNERDF	Distance from posterior of neurocranium to anterior of dorsal fin
TLDF	Total length of dorsal fin
VMCFDMCF	Height of the caudal fin at its beginning, anterior point.

Table 1.7. List of coefficients for discriminant functions of the seven microhabitat guilds (Roanoke River, VA). Microhabitat guild acronyms are as follows: FG=fast-generalist, FR=fast-riffle, PC=pool-covered, PO=pool open, PR=pool-run, RR=riffle-run, and SR=shallow-rheophilic. See Table 1.2 and Table 1.3 for descriptions of the variables.

Variable	FG	FR	PC	PO	PR	RR	SR
Constant	-240.37	-231.89	-265.20	-278.99	-250.18	-231.89	-263.69
ACFL	94.43	87.33	116.97	156.08	98.41	106.29	154.65
ADFAF	303.64	303.94	309.00	302.03	306.61	208.47	224.46
CFAREA	-0.82	-2.01	1.12	0.88	2.06	-0.98	-0.78
CPD	136.08	205.08	89.63	51.56	83.67	144.03	267.72
EYESIZHD	257.25	231.74	301.32	321.53	278.19	232.22	244.66
HD	416.81	313.05	436.70	472.53	432.06	303.85	335.17
MAXPEC	376.04	304.66	407.94	421.78	380.20	311.31	474.81
MBDMBW	-51.71	-45.31	-39.95	-39.85	-37.89	-42.37	-48.07
MDFS	-15.17	-31.67	-60.67	-116.76	-31.44	-35.38	-7.31
PECAREA	11.56	13.53	12.18	12.81	8.53	12.44	12.96
PELAF	57.46	75.10	32.72	29.90	25.47	111.65	26.16
PFL	104.35	167.33	37.56	6.28	104.65	139.93	129.17
PNERDF	320.74	337.16	334.60	349.41	313.08	323.93	393.22
TLDF	-114.41	-108.94	-92.00	-98.31	-97.61	-60.55	-85.24
VMCFDMCF	567.18	520.29	440.78	426.09	416.93	624.69	386.36

Table 1.8. A list of coefficients for linear discriminant functions of the three mesohabitat guilds (Roanoke River, VA). TLDF is total length of dorsal fins. MBD is maximum body depth and CFL is caudal fin length.

Variable	Generalist	Limnophilic	Rheophilic
Constant	-33.67	-37.88	-27.40
TLDF	-15.96	-15.76	10.86
MBD	136.09	161.82	113.28
CFL	168.33	159.62	128.53

Generalized squared distances between microhabitat guilds produced from discriminant analysis are given in Table 1.9 and for mesohabitat guilds the results are in Table 1.10. For microhabitat guilds, three sets of guilds were closer than average for the entire set of pairs. The fast-generalist guild was closely positioned in space to the fast-riffle guild. The pool-covered guild was closest to the pool-run guild (being the closest pair of all guilds), and, as might be expected, the pool-covered guild was also close to the pool-open guild. The largest distance between two guilds was that of pool-open and riffle-run guilds which was nearly the same distance between pool-open and fast-riffle guilds. For mesohabitat guilds, the generalist guild was much closer to the limnophilic guild than the rheophilic guild (Table 1.10). The limnophilic and rheophilic guilds were farthest apart of any pair. Misclassifications would be anticipated to be highest among guilds spaced close together and least among guilds far apart. Guilds very close together may not actually be separate entities, based on morphological differences. For the seven-guild framework, results suggested that the fast-riffle and fast-generalist guilds may not be distinct, as well as there was little distance among all pool guilds, especially pool-cover and pool-run guilds. For the mesohabitat framework, the generalist and limnophilic guilds were nearly identical, suggesting they were not distinct guilds. In both guild frameworks, generalist guilds were not intermediate distances between extreme habitat types, but rather they were associated with one extreme or the other.

Table 1.9. Generalized squared distances between microhabitat guilds from discriminant analysis. The matrix is symmetrical about the diagonal axis, therefore only the upper portion is given. Guild acronyms are as follows: FG=fast-generalist, FR=fast-riffle, PC=pool-covered, PO=pool open, PR=pool-run, RR=riffle-run, and SR=shallow-rheophilic.

From Guild	To Guild						
	FG	FR	PC	PO	PR	RR	SR
FG	0	9.1	16.9	36.8	16.4	25.7	24.4
FR		0	29.4	52.3	29.2	19.2	34.9
PC			0	9.7	5.8	36.5	25.9
PO				0	23.5	54.9	31.3
PR					0	40.0	28.8
RR						0	39.4
SR							0

Table 1.10. Generalized squared distances between mesohabitat guilds from discriminant analysis. The matrix is symmetrical about the diagonal axis, therefore only the upper portion is given.

From:	Generalist	To Guild	
		Limnophilic	Rheophilic
Generalist	0	0.96	8.84
Limnophilic		0	10.25
Rheophilic			0

For the microhabitat guilds, the overall, posterior misclassification rate was 17.2% (Table 1.11). Microhabitat guilds were plotted with 95% confidence ellipses for samples on canonical variate functions (Figure 1.5). Misclassification rates were highest for guilds with high overlap on the plot. The highest misclassification rates (all above 20%) occurred for the pool-covered, fast-generalist, and fast-riffle guilds, respectively (Table 1.11). Pool-covered guild misclassification was 51.1%, with most misclassified observations being classified into the pool-open (12/47), pool-run (6/47), or fast-generalist (6/47) guilds (Table 1.12). Most misclassified individuals from the fast-generalist guild were misclassified as fast-riffle fishes (14/94) with a few others being misidentified as pool-run (3/94) and shallow-rheophilic (2/94) (Table 1.12). Misclassified

observations from the pool-run guild were divided into two categories, fast-generalist (5/86) or pool-covered (7/86) as shown in Table 1.12. The fast-riffle guild had nearly a 21% misclassification rate with all erroneous observations being classified as riffle-run. All other guilds had less than 14% misclassification rate with pool-open guild having no errors (Table 1.11). The shallow-rheophilic guild also had very few errors with a resubstitution error rate of only 2%.

Table 1.11. Summary of resubstitution error (using holdout procedure) for data set of common Roanoke River fishes used to create the morphology discriminant functions to identify microhabitat guild membership. Microhabitat guild acronyms are as follows: FG=fast-generalist, FR=fast-riffle, PC=pool-covered, PO=pool open, PR=pool-run, RR=riffle-run, and SR=shallow-rheophilic. Priors are the prior probability of an observation being placed into a guild, in this case all guilds had equal prior probabilities.

Variable	FG	FR	PC	PO	PR	RR	SR	Total
Rate	0.2021	0.2093	0.5106	0.0000	0.1395	0.1197	0.0227	0.1720
Priors	0.1429	0.1429	0.1429	0.1429	0.1429	0.1429	0.1429	

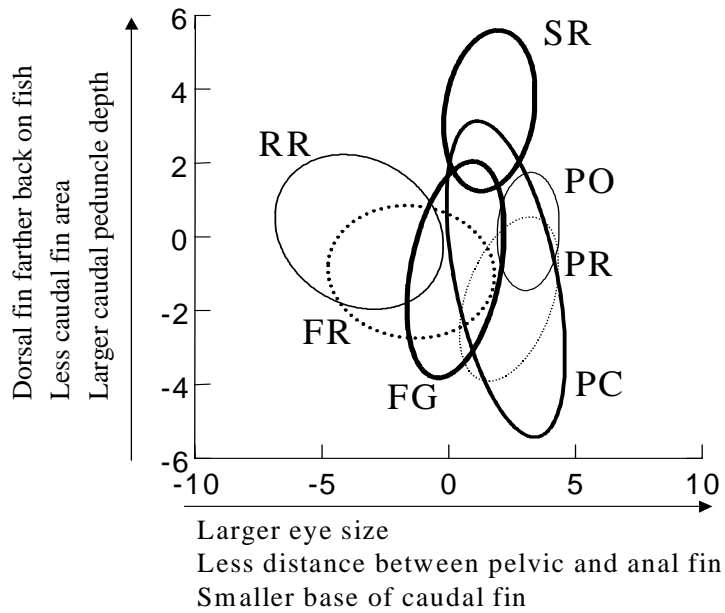

Figure 1.5. Microhabitat guilds plotted with 95% confidence ellipses for samples on the first (abscissa) and second canonical variate functions (ordinate). Guild acronyms are as follows: FG = fast-generalist, FR = fast-riffle, PC = pool-covered, PO = pool-open, PR = pool-run, RR = riffle-run, and SR = shallow-rheophilic.

Misclassified observations from the pool-covered guild were spread across five species, but one species, bluntnose minnow, *Pimephales notatus*, accounted for 50% of errors for the guild (Table 1.13). Nearly all golden redhorse, *Moxostoma erythrurum*, were misclassified and two other species had errors at or above 30%. Most misclassified observations from the pool-covered guild were placed into the pool-open guild, while remaining observations were placed into pool-run or fast-generalist guild in equal number (Table 1.13). Errors for species were usually divided into at least two guilds, except for the redbreast sunfish and golden redhorse with all errors identified as belonging to the pool-run guild (Table 1.13).

Table 1.12. Number of fish (#) and percent of fishes (%) classified from each microhabitat guild (*a priori* classification based on habitat) into the same set of microhabitat guilds based on morphology discriminant functions during holdout tests.

From GUILD	Into							Total (#)
	FG(#)	FR(#)	PC(#)	PO(#)	PR(#)	RR(#)	SR(#)	
	FG(%)	FR(%)	PC(%)	PO(%)	PR(%)	RR(%)	SR(%)	Total (%)
FG	75 79.79	14 14.89	0 0.00	0 0.00	3 3.19	0 0.00	2 2.13	94 100.00
FR	0 0.00	34 79.07	0 0.00	0 0.00	0 0.00	9 20.93	0 0.00	43 100.00
PC	6 12.77	0 0.00	23 48.94	12 25.53	6 12.77	0 0.00	0 0.00	47 100.00
PO	0 0.00	0 0.00	0 0.00	26 100.0	0 0.00	0 0.00	0 0.00	26 100.00
PR	5 5.81	0 0.00	7 8.14	0 0.00	74 86.05	0 0.00	0 0.00	86 100.00
RR	10 7.04	6 4.23	1 0.70	0 0.00	0 0.00	125 88.03	0 0.00	142 100.00
SR	2 2.27	0 0.00	0 0.00	0 0.00	0 0.00	0 0.00	86 97.73	88 100.00
Total	98 18.63	54 10.27	31 5.89	38 7.22	83 15.78	134 25.48	88 16.73	526 100.00

Table 1.13. A list of species with misclassification error during the resubstitution test of the morphology discriminant functions for identifying microhabitat guild membership. The “From Guild” is the *a priori* classification based on reported habitat use.

Species	Number of Errors/Observations	From Guild	To Guild/ Number of Individuals
<i>Hypentelium roanokense</i>	4/17	FG	FR(4)
<i>Nocomis leptacanthus</i>	5/31	FG	PR(3), SR(2)
<i>Scartomyzon cervinus</i>	10/25	FG	FR(10)
<i>Percina roanoka</i>	9/9	FR	RR(9)
<i>Hypentelium nigricans</i>	3/7	PC	FG(2), PR(1)
<i>Lepomis auritus</i>	1/6	PC	PR(1)
<i>Moxostoma erythrurum</i>	3/4	PC	PR(3)
<i>Notropis hudsonius</i>	5/16	PC	PO(4), PR(1)
<i>Pimephales notatus</i>	12/12	PC	PO(8), FG(4)
<i>Catostomus commersoni</i>	9/26	PR	FG(5), PC(4)
<i>Luxilus albeolus</i>	1/23	PR	PC(1)
<i>Luxilus cerasinus</i>	2/37	PR	PC(2)
<i>Campostoma anomalum</i>	17/17	RR	FG(10), FR(6), PC(1)
<i>Phoxinus oreas</i>	1/43	SR	FG(1)
<i>Rhinichthys atratulus</i>	1/44	SR	FG(1)

The incorrect identification of fast-generalist guild members was spread among three species, however, most error belonged to black jumprock, *Scartomyzon cervinus* which accounted for 10 of 19 errors total for the guild (Tables 1.12 and 1.13). When misclassified bluehead chub individuals were placed into either the shallow-rheophilic or pool-run guilds while black jumprock and four Roanoke hog suckers, *Hypentelium roanokense*, were all misclassified as fast-riffle guild members (14/19). Similarly, one species was also the source of most error for the pool-run guild. The white sucker, *Catostomus commersoni*, was misidentified most often from the pool-run guild with mistakes equally spread among the fast-generalist or pool-cover guilds (Table 1.13). Two other species from the pool-run guild had a total of three errors.

All classification error from the fast-riffle guild belonged to the Roanoke darter, *Percina roanoka*. All observations were misclassified as riffle-run guild members (Table 1.13). While all error of misclassification for the riffle-run guild was caused by central stonerollers, *Campostoma anomalum*. Errors were spread among three guilds, fast-riffle (six of the 17 errors), fast-

generalist (10 of the 16 errors), and pool-covered (one error) guilds. For further details of misclassification of species across guilds see Tables 1.13 and 1.14.

The total holdout test classification error was 30.9% for the three-guild (mesohabitat) system. To illustrate overlap in morphology of mesohabitat guilds, they are plotted with 95% confidence ellipses on the first and second canonical variate functions in Figure 1.6. Classification error was 28.9% for the generalist guild, 39.5% for the limnophilic guild and 24.3% for the rheophilic guild. Of 70 errors of the generalist guild, 61 were wrongly placed in the limnophilic guild and all misclassified individuals of the limnophilic guild (34/86) were placed into the generalist guild (Table 1.14). There were 45 misclassified observations of the rheophilic guild and 36 of these were placed into the generalist guild (Table 1.14).

Table 1.14. Number of fish (#) and percent of fish (%) classified from each mesohabitat guild (*a priori* classification based on habitat) into the same set of mesohabitat guilds based on morphology discriminant functions during the holdout test.

From:	Generalist (#)	Into Guild	
	Generalist (%)	Limnophilic (#)	Rheophilic (#)
		Limnophilic (%)	Rheophilic (%)
Generalist	172 71.07	61 25.21	9 3.72
Limnophilic	34 39.53	52 60.47	0 0.00
Rheophilic	36 19.46	9 4.86	140 75.68
Total	242 47.17	122 23.78	149 29.04

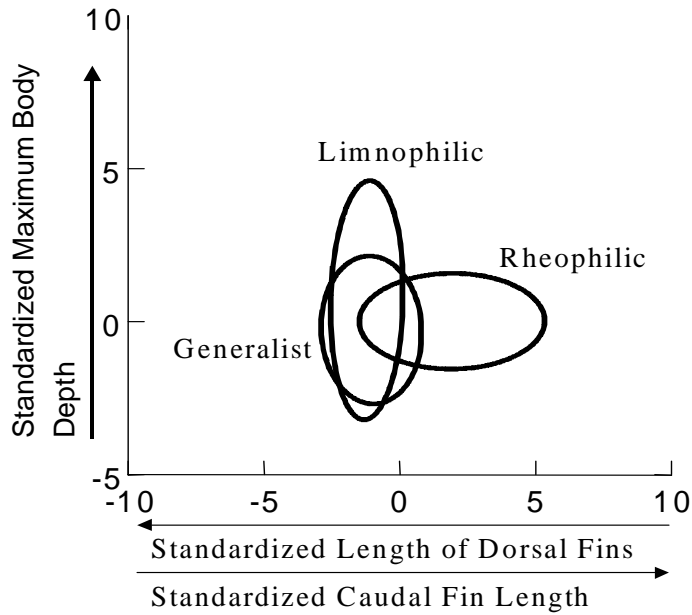

Figure 1.6. Mesohabitat guilds plotted with 95% confidence ellipses for samples on the first (abscissa) and second (ordinate) canonical variate functions.

Microhabitat Guild Model Testing

Removing Individual Species Before Variable Selection

Most of the variables selected across all 23 different analyses were similar to variables selected when using all species. Nine analyses added variables (Figure 1.7) while most of the other analyses dropped an average of three variables (Figure 1.8). The most commonly dropped variables were head depth, caudal peduncle depth, pectoral fin length, and measurement of pelvic fin to anal fin. All analyses dropped variables and 17 of these dropped three or more variables. The variables that were most often added into sets were caudal fin length (three times) and trunk shape (four times). Overall, the presence or absence of just one species did not have much influence over the variable selected for use in morphological functions.

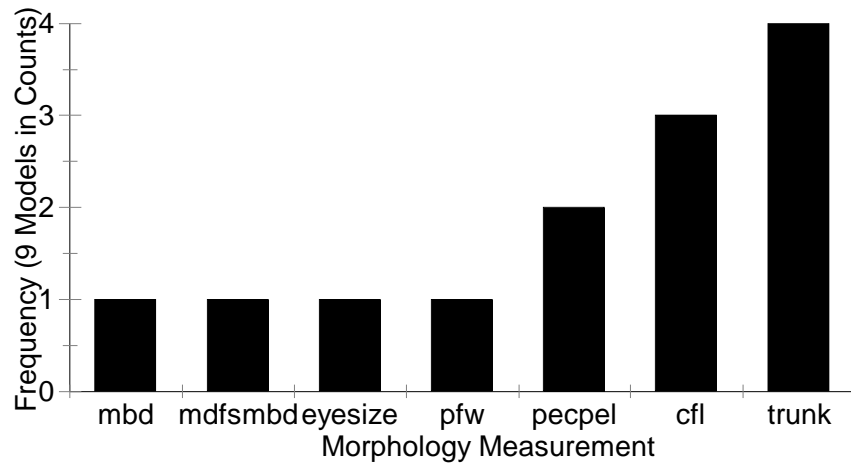

Figure 1.7. The morphology measurements selected during stepwise analysis and their frequency of addition when each species of fish was removed from the model, one at a time, before stepwise discriminant analysis. All measurements except MDFSMDB and TRUNK were divided by fish standard length. MBD = maximum body depth. MDFSMDB = maximum dorsal fin span divided by maximum body depth. EYESIZE = eye size. PFW = pectoral fin width. PECPEL = distance between anterior of pectoral fin and anterior of pelvic fin. CFL = caudal fin length. Trunk = Maximum body depth divided by maximum body width.

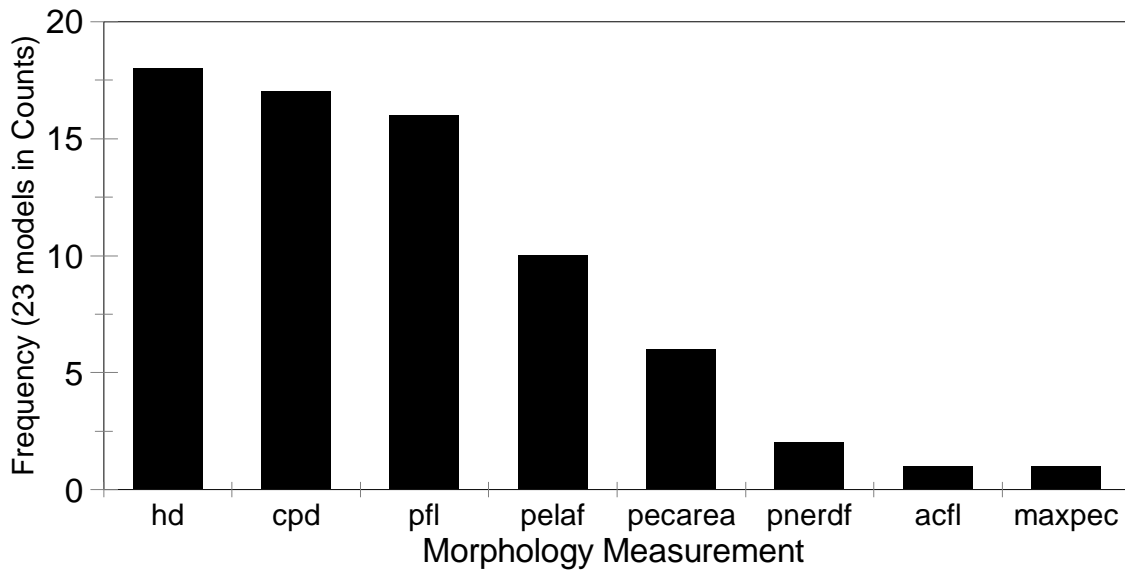

Figure 1.8. The morphology measurements that were no longer selected for the model and their frequency with which they were removed as each species was removed, one at a time, before stepwise discriminant analysis was performed. PECAREA = pectoral fin area. All variables were standardized to fish standard length. HD = head depth. CPD = caudal peduncle depth. PFL = pectoral fin length. PELAF = distance between anterior of pelvic fin and anterior of anal fin. ACFL = axial caudal fin length. MAXPEC = distance from the posterior of maxillary to anterior of pectoral fin.

Performance of the 23 analyses with a species removed were not very different from that of the unmodified, all-species model (Figure 1.9). Removing white shiners, silver redhorse, *Moxostoma anisurum*, or blacknose dace produced the greatest change in overall error rates, nearly increasing error six points (to about 23%). The largest decrease in overall error rate was achieved by removing bluehead chubs, *Nocomis leptocephalus*; a decrease of just two points (to 15.4%). In summary, these results suggested that discriminant functions performed consistently across models with the absence of an individual species, suggesting that misclassification error was not influenced by the presence or absence of a single species.

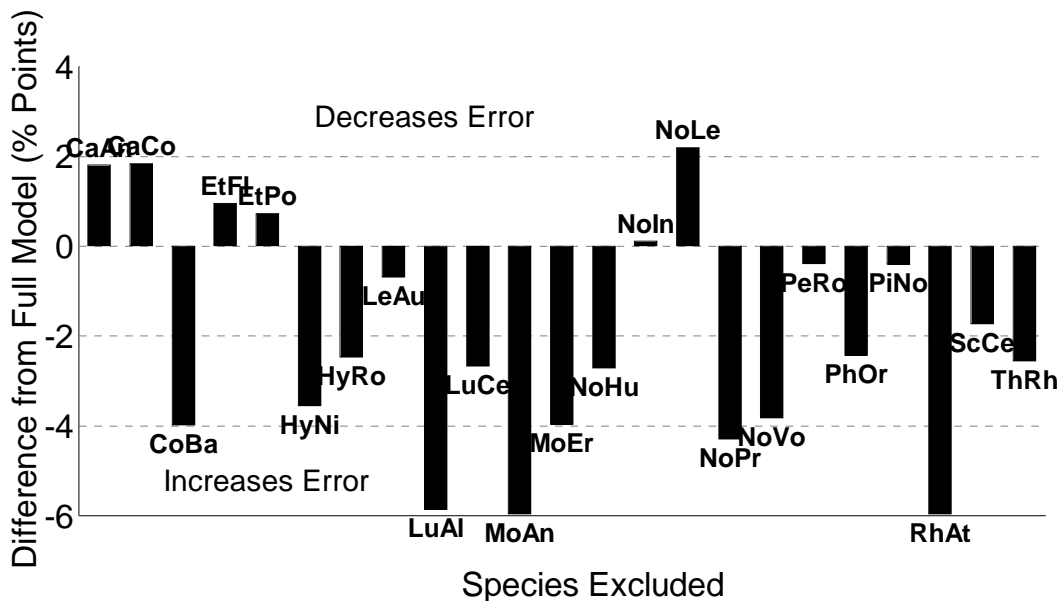

Figure 1.9. The difference in error rate shows how the alternative model (created by removing one species before stepwise discriminant analysis) fared relative to the model with all species in a comparison of total posterior misclassification rates. CaAn = *Campostoma anomalum*. CaCo = *Catostomus commersoni*. CoBa = *Cottus bairdi*. EtFl = *Etheostoma flabellare*. EtPo = *Etheostoma podostemone*. HyNi = *Hypentelium nigricans*. HyRo = *Hypentelium roanokense*. LeAu = *Lepomis auritus*. LuAl = *Luxilus albeolus*. LuCe = *Luxilus cerasinus*. MoAn = *Moxostoma anisurum*. MoEr = *Moxostoma erythrurum*. NoHu = *Notropis hudsonius*. NoIn = *Noturus insignis*. NoLe = *Nocomis leptoccephalus*. NoPr = *Notropis procne*. NoVo = *Notropis volucellus*. PeRo = *Percina roanoka*. PhOr = *Phoxinus oreas*. PiNo = *Pimephales notatus*. RhAt = *Rhinichthys atratulus atratulus*. ScCe = *Scartomyzon cervinus*. ThRh = *Thoburnia rhothoeca*.

Removing Individual Species Immediately Before Discriminant Function Construction

Overall posterior misclassification rates of the 23 analyses were not very different from that of the unmodified all-species model. Decreased error was found in 17 of the analyses. However, these changes were only one to three points (Figure 1.10). Similarly, increased error was found in six of the altered models but error increased less than 1% in all cases. Classification of individuals that were withheld (validation sets) was poor (Figure 1.11). Fifteen of 23 species experienced misclassification at greater than 40% with 12 of these being above 80%. Error rates were lowest for removed species that had a related species of the same genus and guild still in the

model (such as *Notropis*, *Luxilus* and *Etheostoma*) and highest (almost 100%) for those species that had no related species in the model. This suggests the model will correctly identify shape (members of the same genus or similarly shaped individuals), but the model will not be able to correctly identify habitat use of species in the same genus but of different habitat types. Similarly, species that are previously unknown to the model should be classified into guilds with similar shaped individuals, but given the variety of body shapes mixed within guilds by including members of different fish families, this classification may or may not be correct.

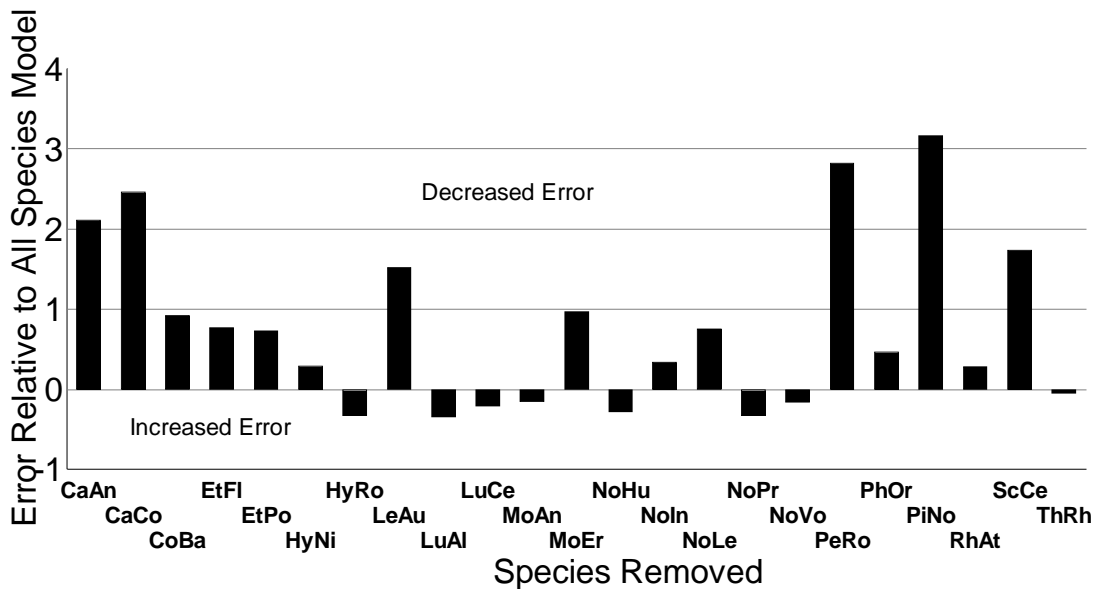

Figure 1.10. The effect of removing a species from the data set after model variables have been selected (post-stepwise discriminant analysis), but prior to calculating the discriminant functions (pre-discriminant analysis), on the total misclassification error (compared to the model when all species have been used). CaAn = *Campostoma anomalum*. CaCo = *Catostomus commersoni*. CoBa = *Cottus bairdi*. EtFl = *Etheostoma flabellare*. EtPo = *Etheostoma podostemone*. HyNi = *Hypentelium nigricans*. HyRo = *Hypentelium roanokense*. LeAu = *Lepomis auritus*. LuAl = *Luxilus albeolus*. LuCe = *Luxilus cerasinus*. MoAn = *Moxostoma anisurum*. MoEr = *Moxostoma erythrurum*. NoHu = *Notropis hudsonius*. NoIn = *Noturus insignis*. NoLe = *Nocomis leptoccephalus*. NoPr = *Notropis procne*. NoVo = *Notropis volucellus*. PeRo = *Percina roanoka*. PhOr = *Phoxinus oreas*. PiNo = *Pimephales notatus*. RhAt = *Rhinichthys atratulus atratulus*. ScCe = *Scartomyzon cervinus*. ThRh = *Thoburnia rhothoeca*.

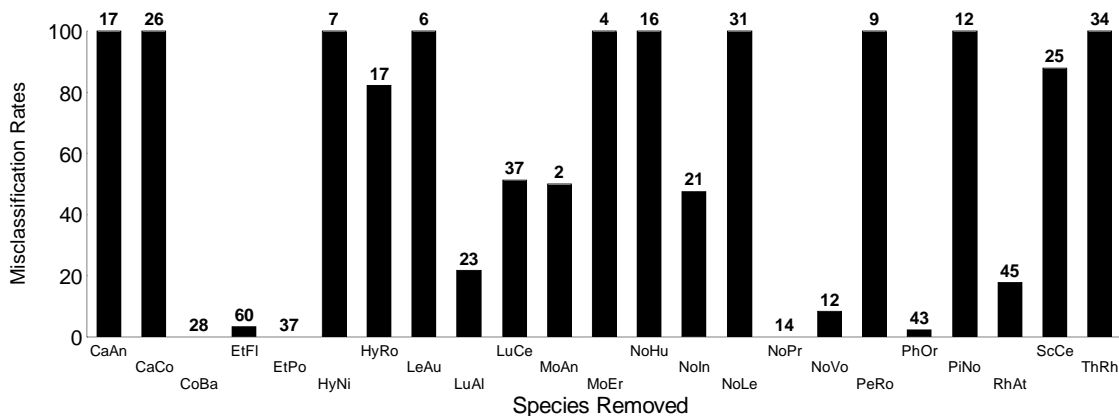

Figure 1.11. The percent of individuals of a species that were misclassified when each species was not used to select variables for morphological functions to identify guild membership. Sample sizes for each species are shown at the top of each column. Error rates were lowest for removed species that had a related species of the same genus and guild still in the model (such as *Notropis*, *Luxilus* and *Etheostoma*) and highest (almost 100%) for those species that had no related species in the model. CaAn = *Campostoma anomalum*. CaCo = *Catostomus commersoni*. CoBa = *Cottus bairdi*. EtFl = *Etheostoma flabellare*. EtPo = *Etheostoma podostemone*. HyNi = *Hypentelium nigricans*. HyRo = *Hypentelium roanokense*. LeAu = *Lepomis auritus*. LuAl = *Luxilus albeolus*. LuCe = *Luxilus cerasinus*. MoAn = *Moxostoma anisurum*. MoEr = *Moxostoma erythrurum*. NoHu = *Notropis hudsonius*. NoIn = *Noturus insignis*. NoLe = *Nocomis leptocephalus*. NoPr = *Notropis procne*. NoVo = *Notropis volucellus*. PeRo = *Percina roanoka*. PhOr = *Phoxinus oreas*. PiNo = *Pimephales notatus*. RhAt = *Rhinichthys atratulus atratulus*. ScCe = *Scartomyzon cervinus*. ThRh = *Thoburnia rhothoeca*.

Removing Guilds with the Highest Mis-Classification

The pool-covered guild experienced slightly more than 50% misclassification and the fast-generalist and fast-riffle guilds had just more than 20% error, using an unmodified, all-species model. When the pool-covered guild was excluded from the model, overall misclassification decreased to 9.2% and pool-run guild misclassification dropped to 4.7%. Other guilds stayed at nearly the same level of error as the model with the pool-covered guild. Removing the fast-generalist guild decreased overall error to 13.0% and decreased error for the fast-riffle (to 16.3%), pool-covered (down to 42.6%) and riffle-run (to 6.3%) guilds. Pool-run and shallow-rheophilic guilds stayed at similar levels to the model with all guilds included. When the fast-riffle guild was excluded, misclassification of the fast-generalist guild decreased to 5.3%. Classification

error of pool-run species increased almost two points while other species remained at approximately the same levels as the full model. Removing guilds with the highest error rates, reduced error by preventing misclassification among guilds with little multivariate space between them, but did little to improve classification of other guilds. This result confirmed that error rates could be reduced by aggregating some guilds together, such as fast-riffle and fast-generalist, and pool-cover and pool-run.

Effect of Data Set Size on Classification Rates

There was very little difference in the average misclassification rates of both guilds and overall error when randomly removing individuals representing 10%, 25%, or 50% of the whole data set (Figure 1.12). Sample size of the data set had no impact on classification rates.

Effect of Sample Size of Species on Same Species Classification

Sample size was important for classifying individuals of the same species for only two of six species examined (Fig. 1.11). There was little difference between the small sample treatment and large sample treatment for fantail darters, *Etheostoma flabellare*, riverweed darters, *Etheostoma podostemone*, mountain red belly dace, *Phoxinus oreas*, and blacknose dace, *Rhinichthys atratulus*. However, crescent shiners, *Luxilus cerasinus*, and torrent suckers, *Thoburnia rhothoeca*, experienced high misclassification rates (>25% and >85%, respectively) for the small-sample treatment and relatively low error for the large-sample treatment (<20% and <15%, respectively).

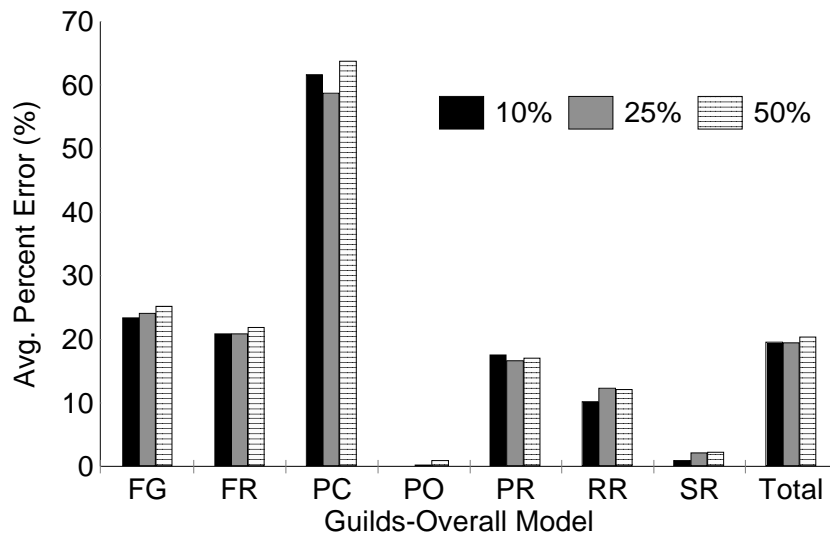

Figure 1.12. The results of randomly removing a percentage of the data (10%, 25%, or 50%) set on total posterior misclassification rates for habitat guilds (FG = fast-generalist, FR = fast-riffle, PC = pool-covered, PO = pool-open, PR = pool-run, RR = riffle-run, SR = shallow-rheophilic) and overall model error (Total).

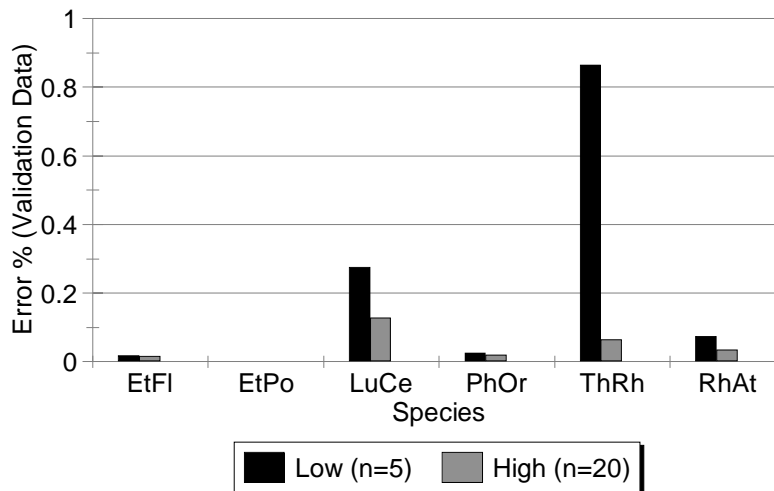

Figure 1.13. A plot of posterior classification error of withheld individuals of a species when either five or 20 individuals of the same species were used in the construction of discriminant functions. EtFl = *Etheostoma flabellare*. EtPo = *Etheostoma podostemone*. LuCe = *Luxilus cerasinus*. PhOr = *Phoxinus oreas*. RhAt = *Rhinichthys atratulus atratulus*. ThRh = *Thoburnia rhothoeca*.

Effect of Collection Site on Species Classification Rates

Six species were examined for differences in classification within species based on their site of collection (Figure 1.14). Three species had representatives from across more than five sites, two species were represented by four sites while the sixth species was represented by individuals from three sites. Classification error rates were less than 10 percent regardless of which site was used in discriminant function construction for the species of blacknose dace, *Rhinichthys atratulus*, riverweed darter, *Etheostoma podostemone*, fantail darter, *E. flabellare*, and mountain red belly dace, *P. oreas*. There were large differences among some sites for torrent suckers, *T. rhothoeca*, and crescent shiners, *L. cerasinus*, 68% and 28% error, respectively. The riverweed darter experienced no classification error using any of the collecting sites to construct the model while error was less than 4% percent for fantail darter and mountain red belly dace. The location of collection did influence classification of some species; species with little error regardless of the collection site tended to be more widespread than species with higher error.

Transferability of Discriminant Functions

Using the majority rule, predictions for threatened and endangered species were correct for *Notropis alborus*, *Etheostoma acuticeps*, *Phoxinus tennesseensis* and *Cyprinella whipplei* (Table 1.15). Predictions were incorrect for *Erimystax cahni*, *Percina rex*, *Noturus gilberti* and *Cyprinella monocha* (Table 1.15).

For Powell River species, guild classification was correct for *Rhinichthys atratulus obtusus*, *Etheostoma zonale*, *Hybopsis amblops*, *Percina evides*, *Etheostoma blennioides*, *Etheostoma rufilineatum*, *Notropis telescopus* and *Percina aurantiaca* (Table 1.16). *Cyprinella galactura* was one individual away from being correctly classified. Hence, I list it as tentatively correct because 50% of its six individuals were correct. Classifications of all other species (eight of 17 species) from the Powell River set were incorrect (Table 1.16).

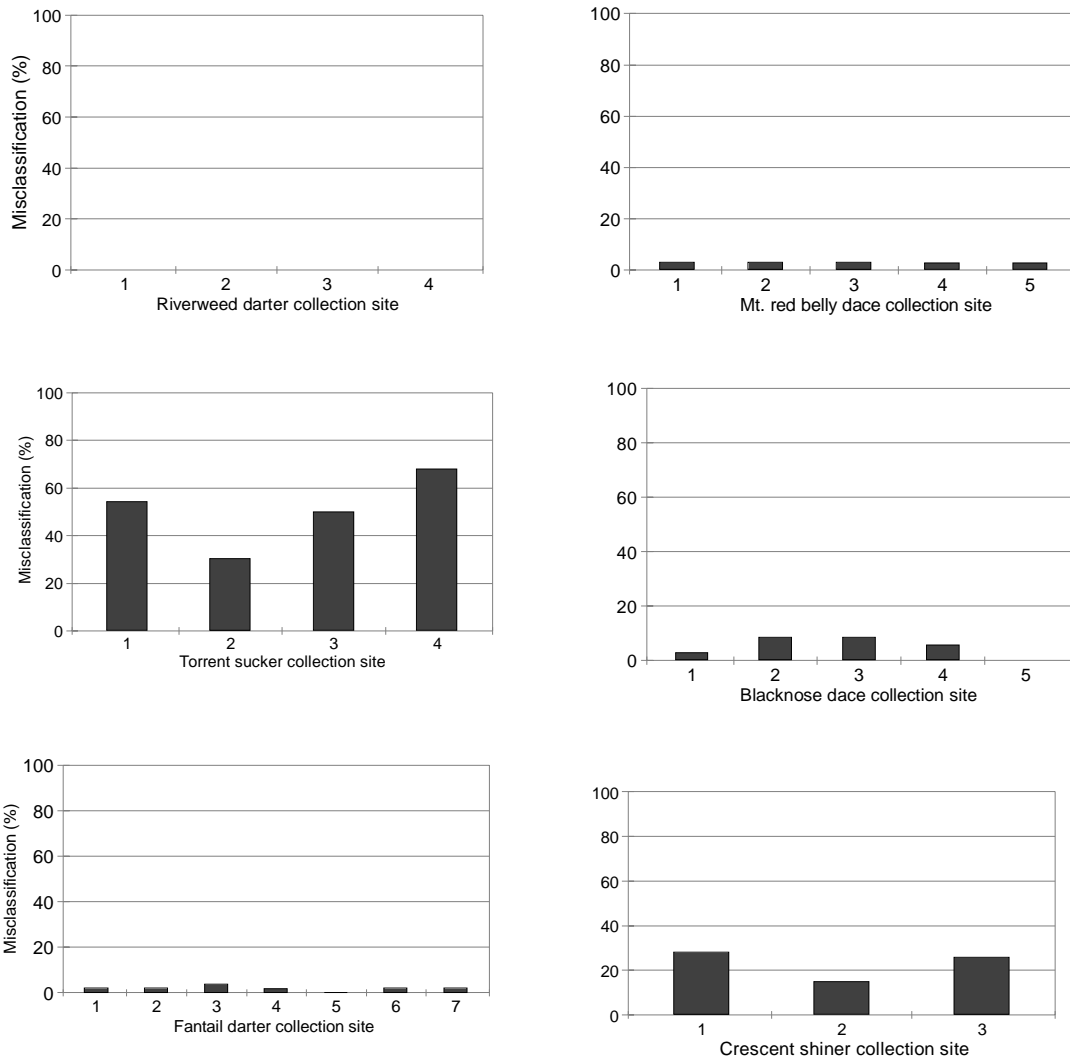

Figure 1.14. The rates of misclassification for individuals of a species when discriminant functions were constructed from other individuals of that same species, collected at only one sampling site. Fantail darter = *Etheostoma flabellare*. Riverweed darter = *Etheostoma podostemone*. Crescent shiner = *Luxilus cerasinus*. Mountain redbelly dace = *Phoxinus oreas*. Blacknose dace = *Rhinichthys atratulus atratulus*. Torrent sucker = *Thoburnia rhothoeca*.

Table 1.15. Number of fish and percent of fish (%) classified by morphological functions into each microhabitat guild for Virginia threatened and endangered fish species. Guild acronyms are as follows: FG=fast-generalist, FR=fast-riffle, PC=pool-covered, PO=pool open, PR=pool-run, RR=riffle-run, and SR=shallow-rheophilic.

Species	Into						Total	
FG	FR	PC	PO	PR	RR	SR		
<i>Erimystax cahni</i>	0, 0%	0, 0%	5, 50%	5, 50%	0, 0%	0, 0%	0, 0%	10
<i>Percina rex</i>	0, 0%	0, 0%	0, 0%	0, 0%	0, 0%	14, 100%	0, 0%	14
<i>Notropis alborus</i>	0, 0%	0, 0%	0, 0%	5, 100%	0, 0%	0, 0%	0, 0%	5
<i>Noturus gilberti</i>	8, 80%	2, 20%	0, 0%	0, 0%	0, 0%	0, 0%	0, 0%	10
<i>Etheostoma acuticeps</i>	0, 0%	0, 0%	0, 0%	0, 0%	0, 0%	16, 100%	0, 0%	16
<i>Phoxinus tennesseensis</i>	0, 0%	0, 0%	0, 0%	0, 0%	0, 0%	0, 0%	10, 100%	10
<i>Notropis whipplei</i>	0, 0%	0, 0%	1, 14.3%	0, 0%	6, 85.7%	0, 0%	0, 0%	7
<i>Cyprinella monocha</i>	0, 0%	2, 18.2%	7, 63.6%	1, 9.1%	1, 9.1%	0, 0%	0, 0%	11

Table 1.16. Number of observations (individual fish) and percent classified by morphology discriminant functions into each microhabitat guild for Powell River species. Guild acronyms are as follows: FG=fast-generalist, FR=fast-riffle, PC=pool-covered, PO=pool-open, PR=pool-run, RR=riffle-run, and SR=shallow-rheophilic.

Species	Into Guild						Fish (#)	
	FG	FR	PC	PO	PR	RR		SR
<i>Erimystax insignis</i>	0, 0%	0, 0%	6, 55%	0, 0%	5, 45%	0, 0%	0, 0%	11
<i>Rhinichthys atratulus obtusus</i>	0, 0%	0, 0%	0, 0%	0, 0%	0, 0%	0, 0%	5, 100%	5
<i>Etheostoma zonale</i>	0, 0%	0, 0%	0, 0%	0, 0%	0, 0%	10, 100%	0, 0%	10
<i>Hybopsis amblops</i>	0, 0%	0, 0%	7, 64%	4, 37%	0, 0%	0, 0%	0, 0%	11
<i>Percina evides</i>	0, 0%	0, 0%	1, 7.7%	0, 0%	0, 0%	12, 0%	0, 0%	13
<i>Etheostoma blennioides</i>	0, 0%	0, 0%	0, 0%	0, 0%	0, 0%	28, 100%	0, 0%	28
<i>Etheostoma rufilineatum</i>	0, 0%	0, 0%	0, 0%	0, 0%	0, 0%	39, 100%	0, 0%	39
<i>Nocomis micropogon</i>	6, 60%	0, 0%	1, 10%	0, 0%	2, 20%	1, 10%	0, 0%	10
<i>Etheostoma simoterum</i>	0, 0%	0, 0%	0, 0%	0, 0%	0, 0%	7, 100%	0, 0%	7
<i>Campostoma anomalum</i>	7, 30%	16, 70%	0, 0%	0, 0%	0, 0%	0, 0%	0, 0%	23
<i>Luxilus chrysocephalus</i>	0, 0%	0, 0%	3, 27%	0, 0%	8, 73%	0, 0%	0, 0%	11
<i>Phenacobius uranops</i>	1, 20%	0, 0%	3, 60%	0, 0%	1, 20%	0, 0%	0, 0%	5
<i>Notropis telescopus</i>	1, 9%	0, 0%	9, 82%	1, 9%	0, 0%	0, 0%	0, 0%	11
<i>Percina aurantiaca</i>	0, 0%	0, 0%	0, 0%	0, 0%	0, 0%	10, 100%	0, 0%	10
<i>Notropis leuciodus</i>	0, 0%	0, 0%	9, 90%	0, 0%	1, 10%	0, 0%	0, 0%	10
<i>Luxilus coccogenis</i>	1, 7%	0, 0%	9, 64%	0, 0%	4, 29%	0, 0%	0, 0%	14
<i>Cyprinella galactura</i>	0, 0%	0, 0%	3, 50%	0, 0%	2, 33%	0, 0%	1, 17%	6

Discussion

Fish diversity in warmwater streams is a substantial challenge to habitat management, particularly when attempting to predict potential impacts caused by changes to instream flow regimes. Habitat guilds can facilitate analysis of discharge-habitat relationships and are increasingly being applied to instream flow studies. Yet, no scientifically informed method for classifying species into habitat guilds or by habitat use has been developed. Because habitat use of many freshwater fishes remains unstudied, an approach for predicting membership in a habitat guild or useable habitat for these species might greatly improve stream and river management. In this study, the use of ecomorphological relationships were considered as an approach to predicting membership in habitat guilds.

My first hypothesis, i.e., prediction rates will be lower for a seven-guild system than a three-guild system) of morphology-habitat relationships was not disproved. Tests of mathematical models using holdout procedures indicated those misclassification rates of individual guilds and overall error for the seven-guild system were lower than those for the three-guild system. Systems with too few guilds obscure habitat-morphology relationships by lumping morphological forms while simultaneously increasing the range of habitat criteria for each guild by including more species.

Testing of factors influencing prediction rates within the seven-guild system suggested that the presence (or absence) of individual species and sample size of the whole data set did not influence prediction rates. Sample size and sample location for individual species influenced the classification error within some species suggesting models should be constructed with samples of specimens from several sites to accurately describe morphological extremes within species, especially for species do not have widespread distributions. Further, larger sample sizes for species with more morphological variation should be considered. However, most misclassified species were consistently assigned to the same one or two guilds, usually of a similar habitat to their home guild.

Within the seven-guild system, removing the three guilds with the highest misclassification rates (one at a time per trial) decreased error because it eliminated misclassification among guilds of similar habitat types. These consistent misclassifications among some pairs of guilds (seven-

guild system: pool-open and pool-cover, fast-generalist and fast-riffle; three-guild system: limnophilic and generalists) and the morphological distances among these guild pairs suggested that only four or five microhabitat guilds and two mesohabitat guilds were identifiable based on morphology. For example, ad hoc runs of the analysis with five or four microhabitat guilds revealed that the overall system misclassification could be reduced to 12% or 8% error, respectively. Based on morphology, seven habitat guilds may not be present in the Roanoke River system; the four microhabitat guilds would then be fast-rheophilic (fast-generalist and fast-riffle guilds combined), pool (pool-cove, pool-open, and pool-run combined), riffle-run, and shallow-rheophilic guilds. The five-guild system does not combine the pool-run guild into the pool guild. Most other studies of habitat guilds have identified four to six guilds (Bain et al., 1988; Lobb and Orth, 1991; Braaten and Berry, 1997; Vadas and Orth, 1997). The two mesohabitat guilds would only have limnophilic and rheophilic species.

The second hypothesis tested, i.e., generalist guilds will have higher prediction error than non-generalist guilds, was not supported. Generalist guilds did not have the highest error rates; their misclassification rates were similar to other guilds. I expected fishes of the generalist guilds to be intermediate in morphological form to the extremes of fast-water and slow-water species. However, for the seven-guild system fast-generalist species were closely positioned in multivariate space to the fast-riffle guild and for the three-guild system, the generalist guild was much closer to the limnophilic guild. This suggested that either morphology will not distinguish generalist guilds, e.g., generalist species do not exhibit strong morphology-habitat relationships, or the guilds are not truly ecologically different from existing guilds. Because of consistent misclassifications among closely aligned habitat types (discussed above relative to the first hypothesis), I believe these guilds to really be members of other habitat types. For example, of the seven-guild framework the fast-riffle and fast-generalist guilds and pool-cover and pool-run guilds may be combined. I ran the discriminant analysis on this five-guild system for the Roanoke River fishes and posterior misclassification rates were substantially reduced (about 8% overall). Similarly, the generalist and limnophilic guilds of the mesohabitat framework should be merged, except for Roanoke hog sucker, blacknose dace, and black jumprock, which should be moved into the rheophilic guild.

The third hypothesis tested, i.e., error rates will be lowest for guilds with more demanding physical environments such as fast flowing water, was only partially supported. The fast-riffle guild of the seven-guild system tied for the second worst misclassification rate (with the fast-generalist guild). However, all of the error of the fast-riffle guild was caused by the consistent classification of Roanoke darters into the riffle-run guild. The riffle-run guild was identified as an important habitat type for this species even by Vadas (1994). Based on these results, I concluded that the Roanoke darter really belonged in the riffle-run guild, which would eliminate fast-riffle error. Yet, this change would not alter overall results for the hypothesis because in the seven-guild system, the pool-open and shallow-rheophilic guilds also had very low error. The rheophilic guild of the three-guild system did not have substantially lower error rates than the limnophilic or generalist guilds. Primarily, guilds with lower error rates had a lower number of very similarly shaped species within those guilds (e.g., the two species of the pool-open guild were in the same genus). This suggests that morphological predictions of habitat use would be improved if they were performed within families; this result was consistent with the results of Douglas and Matthews (1992) who demonstrated that phylogeny can interfere with the ability of morphology to identify habitat use.

Most work in ecomorphology has been to identify correlations between morphology and ecological function (Gatz, 1979a,b; Page and Swofford, 1984; Moran, 1986; Motta et al., 1995a; Bandyopadhyay et al., 1997). Few studies have tested the predictive ability of these relationships. Tests of ecomorphology relationships, mostly focusing on diet, have pointed to weaknesses in their predictive ability (Felley, 1984, Harder, 1985, Douglas and Matthews, 1992, Shoup and Hill, 1997).

Shoup and Hill (1997) found that ecomorphology diet predictions were not correct for all morphological traits and cautioned against the use of such predictions under a very broad range of conditions including recently disturbed systems, recently formed systems or systems with recent species introductions. Studies with bats demonstrate that body morphology predicts microhabitat use (Crome and Richards, 1988; Barlow et al., 1997; Brigham et al., 1997) but not diet (Bowie et al., 1999). Morphology predicted ecological differences when the morphological traits directly reflected function within the environment under consideration, i.e., microhabitat use), but did not

predict ecological differences when the morphology was an indirect or incomplete measure of the ecological function, i.e., diet).

The morphological functions in this study classified species of the validation sets correctly by shape (at the genus level), but incorrectly for habitat use. Most of the species that were misclassified were assigned to guilds that contained members of their genus from the Roanoke River or into guilds with closely shaped species. For example, two species of *Luxilus* from the Powell River were both classified into the pool-run guild, even though they were from the fast-generalist guild, because in the Roanoke River, the two *Luxilus* species were both members of the pool-run guild. Similarly, *Percina rex* and *Percina aurantiaca* were classified into the riffle-run guild, just like the Roanoke darter, *Percina roanoka*. Darters of the genus *Etheostoma* were all classified as riffle-run species, just like the two *Etheostoma* darters from the Roanoke River. Species of *Notropis* and *Cyprinella* were usually assigned to the pool-cover guild or another pool habitat guild. Species of *Notropis* were present in both the pool-open and pool-cover guild in the Roanoke River and the guilds were relatively unseparated in morphological space based on generalized distances between them. *Phenacobius uranops* and the two species of *Erimystax* were also misclassified into the pool-cover guild. It appears that these species were placed there because they are similar in shape to redhorse suckers which also have an elongated body and down-turned head. Two redhorse suckers were members of the pool-cover guild of the Roanoke River. In summary, the morphological functions were able to identify habitat patterns used by genera, but the discriminant functions were unable to identify differences among species of the same genus that would have identified correct habitat use. This result was consistent with that of holdout tests on the Roanoke River fishes, i.e., removing species one at time before constructing discriminant functions); predicting habitat for withheld fishes was most successful when a member of their genus remained in the model, particularly if they shared the same guild. Fishes with no relatives remaining in the model experienced almost 100% classification error. Morphological functions for identifying habitat use will be most transferable for habitat guilds defined within a family or lower taxonomic level, genus or subgenus.

My results were consistent with those of previous studies. Felley (1984) was unable to predict habitat use in a set of closely related species (cyprinids) and suggested that the failure

might be partly due to inadequate measures of habitat use or that the ecomorphological relationships could not be directly extrapolated for species without a common evolutionary history, i.e., within families). Douglas and Matthews (1992) reached the same conclusion in their study of ecology-morphology relationships for cyprinids, finding that phylogeny constrains morphology-habitat relationships. In this study habitat observations were made at a habitat patch scale. Successes with ecomorphology predictions have come when morphology was directly related to resource through the performance of a key task, such as jaw crushing ability in wrasses and parrotfishes (Wainwright, 1991). Results of this study in combination with those of the literature suggest that morphological functions developed within families may be able to correctly identify habitat use when lifestyle and morphological traits related to the performance of species within their environments are considered.

The habitat guilds commonly defined in the literature and tested in this study did not use criteria relative to performance requirements of fishes. The morphology traits needed to identify microhabitat (seven-guilds) were different from those needed to identify mesohabitat (three-guilds). Similarly, the morphological traits that will identify habitat shifts caused by differences in feeding ability be different from those used to separate swimming performance (Gatz, 1979a,b). Identifying functional use of a habitat will aid the ability of morphology to achieve correct habitat predictions. Also, to date habitat guilds have generally not separate benthic and open-water species, i.e., guilds do not consider segregation of the water column); yet, this is an important axis of resource separation and related to performance requirements for at least one specious family (cyprinids) (Felley, 1984; Matthews, 1998). Differences in morphological adaptations for species holding position rather than continuously swimming may have contributed to the inability of morphology to predict habitat guild membership for some families. Again, to achieve correct predictions of habitat use, morphology must be associated with performance tasks within the environment. For example, benthic fishes across several families are thought to have expanded pectoral fins which may be used as hydrofoils for holding position while pectoral fins of pelagic species are adapted to maneuverability (Webb, 1984, Bandyopadhyay et al., 1997; Gerstner, 1999). Mixing benthic and pelagic species together makes it difficult for morphology to identify relationships of habitat and morphology among guilds. Unfortunately, I did not have sufficient

representatives of benthic or pelagic species among guilds to test this hypothesis, but I did examine relationships of habitat use and morphology within groups of benthic and pelagic species and found that morphology was significantly related to habitat use within groups (Chapter 3).

The reason that the pool-cover guild had the highest misclassification rates of the seven-guild system may be due to several factors. The set of morphology traits in this study included many traits known to be directly related to swimming ability. Pools are by definition slow-water velocity habitats and therefore species of the pool-cover guild probably have few external morphological specializations for swimming. Adaptations for feeding ability (e.g., mouth morphology), behavior, e.g., schooling, or physiological adaptations, e.g., low oxygen tolerance, may be more important to identify differences in use of pool habitat types. Wood and Bain (1995) found that they could not predict centrarchid habitat, which they suggest may have due to the traits they used, similarly biased toward swimming ability. Nelson et al. (1999) found that morphology traits related to feeding were important for understanding habitat use of sympatric catostomids. Further, among years, species of pool guilds showed poor consistency in habitat use, i.e., they were not consistent in their use of just one of the three pool-guilds (Vadas 1994). This observation may have been due to difficulties with sampling methods used by Vadas and Orth (1997, 2000). Based on my observations of electrofishing pool habitats in the Roanoke River, fishes often run out of the sampling area through electric fields. Perhaps more refined identification of habitat use for pool species will be needed in order to establish consistent patterns of habitat use by pool species and identify morphology-habitat relationships.

This study relied heavily on work by Vadas and Orth (1997, 2000) and Temple (1997). Biases of their sample methodology could have influenced the results of this study. For example, Vadas and Orth (2000) collected all life stages, except fry, in their development of habitat guilds. Ontogenetic shifts in habitat use among fishes are well recognized and these shifts correspond to morphological changes (Sagnes et al., 1997). Further in healthy populations, juveniles are more abundant than adults. Therefore, it is likely that habitat guild membership was biased toward younger life stages. Juvenile fishes often use shallower water depth and slower water velocities found along stream margins. Therefore, habitat means for the species may have been below those used by adults while the ranges of habitat use for the species would be wider than those for adults

alone. This probably would result in classification error being spread among similar habitat types as it contributes to a blurring of thresholds among habitat types.

Also, microhabitat shifts commonly occur over a species distribution as well as temporally (Aadland 1993, Vadas and Orth, 2000). Flexibility in habitat use of fishes might account for the wide ranges of habitat means recorded by Vadas and Orth (2000) for many of the species. Using the habitat ranges of all species within a guild to develop habitat criteria for each guild resulted in substantial overlap in physical conditions among guilds. With guild frameworks, fishes are assigned to a guild but can be commonly found in other guild habitats (Aadland, 1993; Vadas and Orth, 2000). Vadas (1994) examined the consistency of habitat use for the seven-guild system and several guilds showed poor or only mediocre consistency of habitat use among years, with species of fast water guilds being most consistent. These problems of guild definition result in indistinct guild boundaries and this should result in errors of classification to occur among guilds of similar habitat types. Even when fish morphology was closely tied to habitat use, it would not necessarily result in good predictions because several guilds other than the assigned guild may also have similar physical definitions. Classification error among closely related habitat types was the most common result of this study.

The use of morphology to predict habitat preference (guild membership) still remains a potentially useful tool for water resource managers assessing instream flow changes in areas with diverse fish assemblages. Results of this study indicated that morphology will most successfully identify habitat use when (1) more rather than fewer discrete guilds are used, (2) generalist guilds are not used, (3) guilds are defined within families and consider lifestyles, and (4) morphology traits reflect function with habitat types, i.e., to distinguish among pool guilds, morphology must be related to tasks required of life in pools). Future investigations of habitat-morphology relationships should consider a separate guild system for identifying habitat use (ecomorphological guilds) than the habitat guilds used for instream flow analysis. Ecomorphological guilds should contain more, discrete guilds and be defined with fish families or large genera/subgenera. This more expansive ecomorphological guild system can be condensed across families and lifestyles to provide the four to six habitat guilds for flow analysis. In summary, morphological functions did classify species correctly based on shape. When shape differences are correctly associated with

habitat use, morphology will identify habitat use.

Chapter 2. A phylogenetic approach to using surrogate species: Do closely-related surrogate species tell us more than distant relatives?

Abstract

This study examined methods of choosing surrogates for identifying habitat use of target fishes, including closely-related surrogates as determined from phylogenetic trees, surrogates chosen from within families, surrogates from within families using the same mesohabitat, and surrogates from within the same genus or subgenus (minnows and darters). Habitat was considered at two scales: mesohabitat (riffle, run, and pool) and microhabitat (depth, water velocity, and substrate). Of 34 target-surrogate pairs, 29 pairs overlapped in use of mesohabitat. Considering microhabitat variables independently, overlap occurred in 91% of pairs for depth, 84% of pairs for velocity and 92% of pairs for substrate. Comparisons of target-surrogate pairs to non-surrogate pairs showed that using surrogate species was not capable of producing pairs with more overlap in habitat use. Comparing minnows and darters of the same mesohabitat, e.g., pool, riffle-run, or riffle habitat users, produced higher percentage of matches than using surrogate pairs of minnows and darters or using matches within minnow genera. However, matches within darter subgenera and darters using a single mesohabitat type, e.g., riffles, were 100% in both cases. Substrate matches were consistently high among comparison types (generally >80%) because most species were recorded as using a wide range of substrate types. Also, the division (thresholds) of microhabitat categories used in this study may have been at too large a scale to delimit some habitat differences for darters. Habitat matches for darters were nearly 100% for all comparison types because darters were more limited in habitat use as a family than minnows. An additional factor that increased habitat matches for all comparison types was the fact that most species in this study were from a similar physiogeographic province, valley and ridge. Habitat matches, particularly for substrate, may have been fewer if more comparisons were made for species in different geographic regions, i.e., mountain and Piedmont fish comparisons). In summary, results suggest for species using a single mesohabitat type, surrogates within the same physiographic province and mesohabitat type provide better matches than "nearest phylogenetic taxa" do. For species using several mesohabitat types, tentatively species within the

lowest taxonomic grouping, e.g., genus or subgenus, may provide the best surrogates.

Introduction

Instream flow analysis is used to estimate the trade off among incremental changes in stream discharge and available physical habitat of aquatic species. In order to make this relationship ecologically relevant, knowledge of what constitutes suitable habitat for a species is required such that the amount of suitable habitat relative to the amount of available habitat is known. However, habitat use data are unavailable for many species.

There are three main approaches to developing habitat suitability criteria for species: (1) empirical measurements, (2) guild, and (3) phylogenetic. Whereas the empirical method is expensive and time consuming and the guild method lacks a theoretical foundation for identifying membership without measuring habitat use, a phylogenetic method holds promise because it is efficient and has a valid theoretical foundation for identifying habitat use.

Empirical measurement of habitat use has been advocated as the best approach for developing suitability criteria (Moyle and Baltz, 1985; Glozier et al., 1997), however, such evaluations are not always possible due to resource or time constraints (Williams et al., 1999). In addition, studies have questioned the statistical transferability of values for habitat use of the same species from different streams (Newcomb et al., 1995; Freeman et al., 1997) and statistical approaches to determine transferability have been recommended (Thomas and Bovee, 1993). Testing transferability of data requires field studies of habitat use in the study stream and may require significant sampling effort to meet minimum sample sizes needed for statistical procedures for rare fishes (Thomas and Bovee, 1993). In order to overcome problems of empirical determination, habitat guilds have been suggested as an alternative approach.

Habitat guilds are composed of groups of fishes (regardless of phylogenetic background) using similar physical resources within the river (Leonard and Orth, 1988; Aadland, 1993; Vadas and Orth, 1997). Habitat suitability criteria for guilds, i.e., depth, velocity, substrate characteristics, are developed using all member species as observations. Hence, guilds reduce sampling effort. Guild criteria are either used in flow models in place of species criteria or criteria of a representative species from each guild is used in flow analysis (Leonard and Orth, 1988).

The drawback of the habitat guild approach is the lack of a credible theoretical foundation to determine guild membership. Habitat use information must already be available or is transferred from other sites to classify species into habitat guilds. In an earlier study, I attempted to identify guild membership using morphological discriminant functions (Chapter 1). This attempt was unsuccessful because habitat guilds aggregate species of many families together and therefore morphological variation was not sufficiently related to habitat use within guilds. Guilds may make instream flow analysis more efficient and representative of fish community habitat changes, but do not overcome the problem of absent or sparse habitat information for species.

A phylogenetic approach holds promise as an alternative method to overcome sparse or absent habitat use information in determining suitable habitat criteria, especially for rare fishes or communities. In a phylogenetic approach, habitat use information from a closely related, surrogate species is used for criteria of a target species. The use of surrogates to produce information for rare species and communities is often employed in conservation (Stoeckel, 1993; Caro and O'Doherty, 1999). This approach may be especially useful for cyprinids and darters, two specious fish families for which quantitative habitat information is lacking for many species, and for rare, threatened or endangered fishes where empirical studies may be problematic due to limited sample sizes. The approach would likely be used when habitat use information for a target species is not available from other streams, resources are not available to support empirical studies, when degraded habitat conditions raise questions about the validity of habitat use observations, or when target species are rare and collecting adequate sample sizes or impacts of sampling on species are concerns.

The theoretical foundation for a phylogenetic approach is based on the premise that closely related species share similar morphological, physiological and behavioral constraints. For some time, it has been known that morphology closely correlates with habitat and trophic resource use in fishes (Gatz, 1979a,b; Page and Swofford, 1984, Vogel, 1994). Morphology has been related to swimming ability through streamlining (Aleev, 1969; Hawkins and Quinn, 1996) and fin shape (Felley, 1984; Sambilay, 1990; Gerstner 1999) and to trophic resource segregation in cottids (Norton, 1995) and other fishes (citations in Motta et al., 1995a,b; Shoup and Hill, 1997). Morphological similarities were directly related to similarities in task performance or

habitat requirements. Likewise behavioral constraints to habitat use such as reproductive strategy are also closely related to phylogeny. Johnston and Page (1992) reported eight major reproductive strategies within North American cyprinids and their results showed that species of the same genus shared the same reproductive strategy with few exceptions. Reproductive strategies were directly related to habitat use such as crevice-spawners, nest building in gravel substrates and egg-clustering on rocks or plants. Because closely-related species share similar physical constraints, phylogenetic relationships among species may be used as indicators of habitat requirements and more closely-related species should share similar habitat preferences.

To date a phylogenetic approach has not been thoroughly developed (Harrison and Crespi, 1999), leaving questions regarding implementation unanswered. How widely available are phylogenetic trees? Phylogenetic trees are working hypotheses (Smith, 1992) and may change through time, how do such changes impact transferability of habitat requirements from surrogate to target species? Not all species have sister species (Figure 2.1). Species may be closely related to several species or have no closely related, extant relatives. How "closely related" is close enough? Currently, managers have little to guide them when deciding when and how to apply this approach.

This study was designed to examine the efficacy of a phylogenetic approach for identifying habitat use of fishes. The objective of this study was to address the following question: Do closely related surrogate species offer better habitat information than distantly related surrogate species? Specifically I hypothesized that pairs of species identified as the nearest relative using phylogenetic trees would have a higher percentage of habitat overlap than pairs of species of the same family, same mesohabitat, or the same genus or subgenus.

Methods

Target species were selected as common fishes of the Roanoke and Powell rivers, Virginia, as well as threatened and endangered fishes of Virginia. Surrogate species were then identified for each target species as the most closely positioned taxa relative to a target species, in the most recent and accurate phylogenetic tree available (Figure 2.1). Within studies of phylogeny, solutions for trees may differ according to the analysis used (see Harrison and Crespi,

1999). When more than one tree was reported in a study, the tree identified as the most parsimonious solution was used. In the absence of phylogenetic trees, the taxa most closely related to the target species was identified using Jenkins and Burkhead (1994). When two or more species were positioned equally close to a target species, such as species A and C in scenarios two and three of Figure 2.1, all related taxa were considered to be potential surrogates. The availability of habitat information then became the limiting factor for which species were used as the surrogate in this analysis.

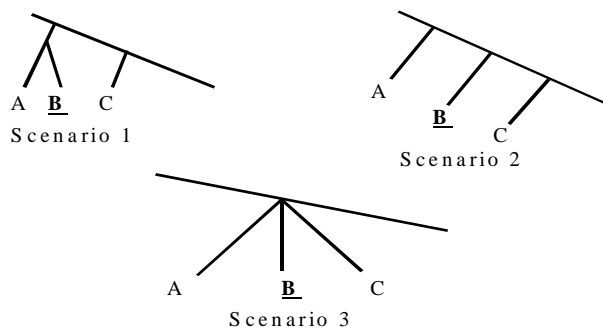

Figure 2.1. Three possible scenarios faced by a researcher attempting to determine the nearest relative of a species. The target species is labeled B. In the first scenario, species A and B are considered sister taxa. In the second and third scenarios, both species A and C were considered as viable surrogates for the target species.

Surrogate species were not found for six target species. A well-developed phylogeny of the genus *Cottus* was lacking and therefore a surrogate for *Cottus bairdi* was not available. The closest relative of the spottail shiner was uncertain (Jenkins and Burkhead, 1994) and no information was found on the phylogeny of *Campostoma*. No reference for the closest relative of *Nocomis leptocephalus* was found, although phylogenetic relationships for some *Nocomis* species are described (Lachner and Jenkins, 1971). The closest relative of *Etheostoma simoterum* was identified as an undescribed species (Page, 1981) and there are no closely related darters to *Percina aurantiaca*, the only member of its subgenus, *Hypohomus* (Page, 1981).

Following identification of target-surrogate species pairs, the primary literature was

searched for qualitative and quantitative studies of adult habitat use. For many target species, quantitative measurements of microhabitat were provided by dissertations of Vadas (1994), and Temple (1997). Vadas (1994) and Vadas and Orth (1997, 2000) collected fishes in microhabitat quadrants over two years, during warmer seasons at six stations in the upper Roanoke River, VA. Stations had channel thalweg lengths of 460-655 m. Samples were taken in five mesohabitat units, established visually (medium pool, shallow pool, run, slow riffle, fast riffle) and then mesohabitat units were sampled proportional to their abundance.

Fish and microhabitat samples were taken within mesohabitat units using quadrats that were approximately 20-50 m² in surface area. Fish species (all life stages except fry) were sampled with a seine net and electrofishing (streamside generator) above a block net. Species densities were used to establish fish-habitat relationships and habitat-use guilds. Quadrat size varied with the homogeneity of hydraulic and channel roughness characteristics; quadrats taken in rapidly varying areas such as riffles had smaller areas and those in more uniform sections such as pools employed larger areas. Each station had 42 to 80 quadrat samples, which sampled approximately 20% of the area of each mesohabitat unit at a station. Within each quadrat, water depth, demersal velocity (4.5 cm from bottom), water-column velocity (0.6 depth), and substrate size (nine categories were determined for three locations along a diagonal from one corner to another (Vadas and Orth, 1997). Average substratum size was determined using the first, second, and third most frequent substratum types (Vadas and Orth 1997).

Temple (1997) sampled microhabitat of fishes using 4 m x 2 m electrofishing grids, four grids per transect, and six transects per site. Riffle, runs, and "head runs" were sampled with grids. Microhabitat (water depth, water-column velocity, and substrate) was sampled at the four corners of the grids. Substrate was transcribed to the numeric system of Vadas (1994) and then a mid-point of the range was assigned to each species.

Descriptions of habitat for threatened and endangered target species were taken from Terwilliger et al. (1995), but these were mostly qualitative. From all sources, mesohabitat use (riffle, run or pool) and observations of microhabitat use (water velocity, depth, and substrate use) were identified.

All quantitative microhabitat was converted to qualitative categories for direct comparison

using threshold criteria for habitat guilds described by Aadland (1993). Water depth codes were: shallow (<55 cm), medium (55 - 120 cm) and deep (> 120 cm). Water velocity codes were: slow (< 30 cm/s), moderate (30 - 60 cm/s), and swift (>60 cm/s). Substrate use as reported in the literature was translated into the following categories: silt (<1 mm), sand (1-2 mm), pebble (2-16 mm), small gravel (16-32 mm), large gravel (32-64 mm), small cobble (64-128), large cobble (128-256 mm), boulder (>256 mm) and bedrock and then the range of use was recorded.

Qualitative descriptions of microhabitat were also used, but these were avoided in favor of quantitative observations whenever possible. Descriptions of depth and water velocity were considered directly equivalent to categories employed here. For example, "swift," "torrent," or "rapid" or "fast" water was considered to be equal to the swift category of water velocity defined above. Whenever authors employed several terms together in a hierarchy, the ranking of the terms was considered equal to the rank of terms used in this study, i.e., a term used as the slowest descriptor of water flow would receive a mark for using the lowest category of flow used in this analysis and similarly for middle and highest ranking terms. When substrate was reported in generic terms such as "gravel," the term was considered to represent all possible size ranges of that substrate, i.e., "gravel" was interpreted to represent the use of both small and large gravel categories. The term "rocky" was found several times in the literature and I interpreted it to mean the use of all substrate sizes equal or larger than small gravel (>16 mm). The use of terms "all," "variety," "generalist," and "as available" were translated to mean the use of all substrate categories. Silt was used as the catch category for reports of "clay" because of its similar size, although use of "clay" habitat was rarely reported.

Using all reported habitat data I could find, species were marked as to their habitat range within each habitat category. Species could be marked as using more than one category for each variable. For example, within mesohabitat types (run, pool, riffle), a species could be considered to use one, two, or all three categories of mesohabitat given that the literature supported it. References for habitat use of target and surrogate species are given in Appendix F.

To determine if habitat requirements were similar among target-surrogate pairs, the number of pairs with overlapping habitat were recorded for mesohabitat use and within each microhabitat category. Comparisons were also made for all surrogate minnow pairs and darter

pairs. Additional comparisons were made for all possible minnow pairs, darter pairs, pairs of minnows and darters using the same mesohabitat categories, and pairs of minnows and darters within two selected minnow genera and darter subgenera. Examples of two comparisons are given in Table 2.1. Species that did not have data for at least two microhabitat categories were excluded from comparisons. Trends in successful matches among comparison types were examined to determine if surrogates provided a higher rate of success than other types of comparisons.

Table 2.1. Examples of how overlap in habitat use was determined for pairs of fish species, using mesohabitat, water depth, and water velocity categories.

Species	Reported Habitat Use		
	Mesohabitat	Depth	Water Velocity
Target	Pool, Run	Medium, Deep	Slow
Surrogate	Run, Riffle	Shallow, Medium	Slow, Moderate
Overlap	Yes (Run)	Yes (Medium)	Yes (Slow)
Species 1	Riffle	Shallow	Swift
Species 2	Riffle, Run	Shallow, Medium	Moderate
Overlap	Yes (Riffle)	Yes (Shallow)	No

Results

Of 45 target species, surrogate species were identified for 39 fishes (Appendix F). Of 39 pairs, only 34 were unique, i.e., five pairs were reciprocal matches of earlier pairs, e.g., sister taxa, and therefore these five matches were dropped from further analysis so pairs were not counted twice. Of these 34 unique pairs, substantial overlap in usable habitat was present for both meso- and microhabitat.

Overlapping use of mesohabitat types was evident for 29 of 34 target-surrogate pairs (Table 2.2). Nineteen pairs had exact overlap in mesohabitat use. Fourteen of these pairs were reported as residents of one habitat type, e.g., riffle vs. riffle, and five pairs reportedly used two or more habitat types, e.g., riffle and run. There were an additional 10 pairs with partial overlap in mesohabitat. The species of one of these pairs used several habitat types, but overlapped in only

one category. Nine of these pairs had one species that used two or more habitat types while their nearest relative used only one of these habitats.

Target-surrogate pairs exhibited a high percent of overlap in microhabitat use (Table 2.2). Overlap in habitat among target-surrogate pairs was 85% for mesohabitat (29 of 34), 91% for water depth (22 pairs), 84% for water velocity (25 pairs), and 92% for substrate (25 pairs). However, target-species pairs within families, minnows and darters, had a lower percent of matches. Overlap in microhabitat use was evident for only about 80% of most target-surrogate pairs of minnows. Target-surrogate pairs of darters were consistent in using shallow microhabitat (100% overlap), but overlap occurred for only 70% of the velocity and substrate comparisons (Table 2.2).

When comparing all possible pairs of minnow species, except target-surrogate pairs, the percentage of pairs with overlap in habitat use was the lowest of all types of comparisons attempted (Table 2.2). Mesohabitat type overlapped for only 56% of pairs and water velocities overlapped for only 51% of pairs. Overlap of all possible pairings of darters, excluding target-surrogate pairs, was good, 80% for all categories except for depth which was better at 100% (Table 2.2). However, most of the pairs not having habitat overlap were pairings that included *Etheostoma kennicotti*. This darter was unusual because its reported habitat was a pool of shallow depth and slow water velocities over bedrock (Page, 1975). If this darter was excluded, then overlap for pairs of darters would be 93% for mesohabitat use, 100% for depth, 93% for water velocity, and 93% for substrate use.

Table 2.2. The percent of pairs having habitat overlap within different types of comparisons. The number of pairs having overlap is given over the number of comparisons made in parentheses.

Comparison Type	Mesohabitat matches (%)	Depth matches (%)	Velocity (%)	Substrate (%)
Surrogates	85 (29/34)	91 (20/22)	84 (21/25)	92 (23/25)
Surrogates - minnows	84 (16/19)	72 (8/11)	78 (15/19)	81 (13/16)
Surrogates-darters	78 (7/9)	100 (7/7)	71 (5/7)	78 (7/9)
Minnows	56 (206/369)	81 (215/267)	51(187/369)	82(301/369)
Pool Minnows	97 (67/69)	90 (44/49)	100 (69/69)	86 (59/69)
Riffle-Run Minnows	100 (5/5)	100 (5/5)	60 (3/5)	80 (4/5)
<i>Notropis</i> Minnows	78 (14/18)	83 (10/12)	78 (14/18)	83 (15/18)
<i>Luxilus</i> Minnows	100 (10/10)	70 (7/10)	70 (7/10)	100 (10/10)
Darters	82 (69/85)	100 (85/85)	82 (69/85)	80 (68/85)
Riffle Darters	100 (20/20)	100 (20/20)	100 (20/20)	100 (20/20)
Riffle-Run Darters	100 (9/9)	100 (9/9)	78 (7/9)	100 (6/9)
<i>Percina</i> Darters	100 (3/3)	100 (3/3)	100 (3/3)	100 (3/3)
<i>Nothonotus</i> Darters	100 (15/15)	100 (15/15)	100 (15/15)	100 (15/15)

The microhabitat use of both minnows and darters using within similar mesohabitat types was also examined. Results were mixed with some mesohabitat types producing good matches and others with fewer successful matches (Table 2.2). Pool minnows matched well with microhabitat categories having overlap in 86% or more of all categories, but within minnows using both riffle and run mesohabitat types, overlap in microhabitat use was as low as 60% for water velocity and 80% for substrate. For darters using only riffles, comparisons were excellent, 100% overlap, in all three microhabitat categories, but for darters using both riffles and runs, the percentage of pairs with overlap was as low as 67% for substrate and 78% for water velocity.

Comparisons of minnows within the same genus and darter pairs within the same subgenus (including target-surrogate pairs) showed similar results to comparisons of species using similar mesohabitat. Minnows of the genus *Notropis* had poor overlap among species (Table 2.2) with only 78% of possible comparisons having overlap in mesohabitat use. Generally about 80% of pairs overlapped in habitat use among all habitat categories for *Notropis*. Similarly, species of *Luxilus* had only 70% overlap in depth and water velocity categories (Table 2.2). However, more success was evident in matching habitat use among darters of the same subgenus. Darters of the subgenera *Percina Percina* and *Etheostoma Nothonotus* had 100% overlap in all categories.

Additionally, in this study 10 species were listed as rare, threatened or endangered species (Page and Burr, 1991; Jenkins and Burkhead, 1994). Of these 10 species, three had complete overlap in microhabitat use with their nearest relative, one pair did not overlap in water velocity use, one pair did not overlap (mismatch of two of three categories), and five pairs had incomplete data (often lacking for the surrogate species, not just target species).

Discussion

Given current models of population growth and climate warming, more of the human population will be living in water-stressed areas (Vörösmarty et al., 2000). Further, half of all stream flow is already regulated (Petts, 1989). Therefore, decisions regarding water allocation between humans and instream resources will be an important management issue for the foreseeable future. Yet, a lack of information will always be a problem for such analyses, especially for rare fauna, because water demands exceed biological studies (Freeman et al., 1999).

The goal of this study was to evaluate a phylogenetic approach for identifying habitat use of target species by using surrogate species to increase information available for analysis by managers and decision makers.

This study asked the question whether or not more closely related surrogate species give more accurate information about habitat use than distantly related surrogate species. Results of this study do not suggest that more closely related species give better results than picking surrogates for other reasons (e.g., same mesohabitat type). Matches of habitat use of target-surrogate species were lower than almost all other comparison types (except minnows in general). The highest number of pairs with overlapping habitat use occurred for pairs of minnows specializing in one mesohabitat type, i.e., minnows using pools, and darters using riffles, but darters of the same subgenus also had complete overlap in habitat use.

Microhabitat data is known to vary for species in statistically significant ways among streams (Newcomb et al., 1995; Freeman et al., 1997; Novinger and Coon, 2000), but general habitat requirements of species are relatively stable across widely varying geographic locations (Matthews, 1998). Statistical tests of transferability are available (Newcomb et al., 1995; Freeman et al., 1999). However, these approaches were not used in this study to test transferability among target and surrogate species because a phylogenetic approach is not an attempt to identify specific values of habitat use, e.g., optimal, suitable, marginal. Also availability of suitable information for such tests is limited. Rather, a phylogenetic approach attempts to identify a range of suitable habitat for a species or sufficient information to classify a species into a habitat guild when no other information is available. In this case, statistical differences are not representative of practical and biological significance. For example, Newcomb et al. (1995) determined that smallmouth bass in three West Virginia streams had statistically different habitat criteria, however, general patterns of usable habitat were similar among all streams; water velocities greater than 18 cm/s were rarely used, the majority of focal observations were less than 12 cm/s, depths of 0.3 to 1.5 m were used by 94% of bass. These general criteria have biological significance for bass in all three rivers, representing usable habitat, but if tested statistically they would be significantly different from habitat use in any river. Had nothing been known about a bass habitat in a stream, adoption of the range of use of criteria from another stream would have

represented actual linkages between the species and its habitat and been useful for evaluating potential habitat changes caused by flow alteration. Similarly, the identification of a range of habitat use for a target species from a surrogate species is useful and has practical significance even if it does not have statistical significance.

The use of habitat categories in this study facilitated habitat comparisons for many species with a different amounts and type of available data. The microhabitat boundaries used in this study were used to identify six microhabitat guilds for fishes (Aadland, 1993). These limits correspond to habitat thresholds of many other studies (Bain et al., 1988; Leonard and Orth, 1988; Vadas and Orth, 1997). However, I found that the boundaries may be at too large a scale to accurately reflect overlap of some habitat categories for different fish families. For example all but two species of darters used shallow habitats and therefore overlapped nearly 100% in mesohabitat (riffles) and water depths used. Further, mesohabitat type and microhabitat categories were not mutually exclusive, especially since most species were from the same physiographic province, the ridge and valley province of Virginia. For example, pools can be shallow, medium or deep with slow to swift velocities, but because most fish habitats were sampled within one physiographic province (Jenkins and Burkhead, 1994), pool habitat was limited to conditions of these areas. In the rivers studied by Vadas (1994) and Temple (1997), habitat information was generally from streams that lacked very deep pools or pools with rapid flow. Pool species were then constrained to use available habitat (shallow or medium pools) with slow velocities and generally silt to gravel substrates. Therefore, species of single mesohabitat types should exhibit higher habitat overlap than species using two or more guilds, which was consistent with results of this study. Conversely, this result suggests that within a physiographic province, species sharing similar mesohabitat types will also have overlapping use in microhabitat use, and that selecting surrogates that use the same mesohabitat type within areas of similar physiography will more accurately identify habitat for the target species.

Minnows in general had lower overlap in habitat use than darters. This was because minnows were more flexible in habitat use as a group and occupied more habitat types than darters. Darters in general specialized in a shallow-water habitat. However, observations of habitat overlap among darters within the same subgenus were in agreement with observations of

habitat use for darters. Page and Swofford (1984) stated that darters within the same subgenera have similar habitat requirements. Also, for some darters, habitat suitability criteria were found transferable between streams and it has been suggested that criteria among benthic fast water species may be more transferable than species occupying other habitat types (Freeman et al., 1997). This suggested that within benthic species, selecting a surrogate from within the lowest taxonomic unit, e.g., subgenus for darter and genus for minnows, may be the best option for identifying habitat use. Unfortunately, I had an insufficient number of benthic minnows in my analysis to test this hypothesis for minnows.

Some habitat variables had more discriminatory power among the two families examined than other habitat variables. Because substrate was classified using nine size classes, it should have had the most discriminatory power. Overlap in substrate use was consistently high, while overlap in depth and water velocity was more variable. There may be several reasons for this observation. First, available substrate was limited by larger scale factors such as physiographic province and species used what was available. Second, substrate size may not be as important as a microhabitat characteristic compared to other measures of substrate like embeddedness, roughness, or its susceptibility to transport. Third, substrate may only be important periodically, such as during spawning. For example, darters select spawning substrate based on such factors as their susceptibility to transport (Smith, unpublished data). In this study, most species were reported over a wide range of substrate types. Only benthic fish comparisons, riffle-run darters, had high non-overlap of substrate categories. Certainly, overlap in substrate types was stimulated to higher percentages of overlap because most species of this study were from the same physiographic province and substrate was dependent of mesohabitat type, i.e., in general, riffles have similar substrate sizes due to geomorphological factors. However, darters did exhibit differences in habitat use within certain groups of mesohabitat users (e.g., darters using both riffles and runs). In general, substrate size was not a good habitat variable for making comparisons of similar habitat use among species.

In conclusion, to identify a surrogate species that would best match a target species, my study results suggest that using the most closely related taxa does not give better results than selecting a surrogate for other reasons. For minnows and darters, when a target species

specialized in a mesohabitat type, then the highest overlap in habitat use with a surrogate occurs when the surrogate is from the same physiogeographic province and specializes in using the same mesohabitat type. For benthic species in general, selecting a species within the same taxonomic group, e.g., subgenus for darters and genus for most other fishes, seemed to produce equally good results. The use of a phylogenetic approach is probably most appropriate for using surrogates to classify a target fish into a microhabitat guild framework. Further work will need to examine more refined microhabitat categories to determine if the approach is suitable for identifying accurate microhabitat use (water depth and velocity). This approach will facilitate the use of microhabitat guilds and the evaluation of entire fish communities, including rare species, in instream flow analysis.

Chapter 3. Ecomorphological guilds: an approach to identifying habitat preference using a simple hydraulic variable and fish morphology.

Abstract

Minnows and darters are diverse fish families for which little information exists on habitat preference of many species. Methods for predicting habitat preference would enhance stream management by allowing habitat analysis of fish assemblages, instead of selected target species, within instream flow studies. This study examined the relationship of a simple hydraulic variable, Froude number, and the morphology of three ecomorphological guilds (benthic darters, benthic minnows, open-water minnows) and one fish family (suckers). Ecomorphological guilds, as opposed to habitat guilds, group fishes by their evolutionary history and lifestyle, factors that strongly influence fish morphology. Significant relationships were identified for all four groups, however, results indicated that relationships were not transferable across taxa, even for fishes having similar morphology and occupying the same habitat types. For example, within darter species caudal peduncle length decreased as Froude number increased (more surface turbulence such as riffles) while in benthic minnows caudal peduncle length increased as Froude number increased. This study demonstrated the utility of simple hydraulic variables for describing instream habitat and identified relationships of morphology and Froude number. Froude number may be easily obtained in available modeling software. It describes habitat conditions more completely than traditional habitat variables, and its relationship to stream hydrology and channel shape have been well established. This study employed linear regression to describe relationships between Froude number and fish morphology; such relationships may then be used to identify average habitat conditions of other species within guilds by plotting their morphological characteristics on graphs of relationships.

Introduction

Minnows and darters are diverse fish families in North America with inadequate habitat information, and many species within these families are listed as either threatened or endangered under United States federal or state law (Warren et al., 2000). Lack of habitat knowledge for these species prevents more accurate assessment of habitat changes with changes of instream flow when using traditional species-life stage approaches. Further, because these two families comprise a significant portion of the diversity of fish communities, decisions regarding how instream flow changes impact communities remain tenuous until habitat changes for all species can be evaluated.

The potential habitat niche of a species is delimited by its physical ability to use resources; morphology is one constraint on resource use. Fish morphology has been linked to habitat use (Videler and Wardle, 1991; Videler 1993; Vogel, 1994) and morphological design can indicate performance of important tasks such as swimming (Bandyopadhyay et al., 1997; Gerstner 1999; Triantafyllou et al., 2000) and feeding (Wainwright, 1991; Norton, 1995; Nilsson and Broenmark, 2000). Morphology may also limit habitat use through bioenergetic constraints. Habitat types become more costly to use because of design limitations (Facey and Grossman, 1990). Overall, morphology provides physical and bioenergetic thresholds that contribute to habitat selection and a mechanistic understanding of morphology-habitat associations may be used toward identifying habitat preference of a species (Schoener, 1986).

Despite the identification of morphology-habitat relationships among many species, limited research has tested how morphology acts to constrain habitat use of warmwater stream fishes. Douglas and Matthews (1992) suggested that morphology may be a predictor of habitat use within fish families. Felley (1984) and Wood and Bain (1995) confirmed that morphology is predictive within some fish families, including minnows and darters.

In Chapter 1 of this volume, I attempted to use morphological discriminant functions to identify membership of fishes in microhabitat guilds (Vadas and Orth, 1997, 2000). Morphology was able to classify species by shape, but was only partly successful at correctly predicting guild membership, because morphology and habitat use were not closely associated. Because guilds contained fishes from many different families, mixed species of open-water and benthic lifestyles,

and failed to have discrete habitat boundaries, morphology was not closely associated with habitat use. Study results suggested that morphology will be most successful in identify habitat when (1) more rather than fewer discrete guilds are used, (2) generalist guilds are not used, (3) guilds are defined within families and consider lifestyles, and (4) morphology traits reflect function within habitat types, i.e., morphology must be related to tasks required of life in the guild's habitat.

When studies have successfully identified habitat-morphology relationships, relationships did not always transfer to new situations (Gatz, 1979a,b; Felley, 1984; Wood and Bain, 1995). Traditionally, ecomorphological studies have employed multivariate analysis, in particular principal component analysis, to accommodate for non-independence among simple habitat variables, i.e., depth, water velocity, and substrate, and multivariate shape information. However, the use of multivariate habitat variables, i.e., principal components make application of identifiable relationships unlikely in stream management outside of the source study. The use of such components for stream management is unlikely because (1) methods will be constrained to be similar among studies in order to apply the variable, (2) the relationship of multivariate habitat functions, i.e., principal components to stream hydrology are not known or described, (3) multivariate functions describing important shape components are not transferable among families or possibly genera (Felley, 1984; Douglas and Matthews, 1992), and (4) current hydraulic models do not readily incorporate these variables. In this study, I attempt to overcome many of the problems associated with morphological analysis by (1) using ecomorphological guilds that consider both phylogeny and lifestyles, e.g., benthic fishes, (2) using simple mathematical relationships between morphological traits and a habitat variable, and (3) using a simple hydraulic variable, Froude number, to better describe flow characteristics.

The Froude number has traditionally been used to examine movements through surface flow (Vogel, 1994) and describe bulk flow characteristics within stream reaches (Gordon et al., 1992). However, recent ecological investigations have used Froude number to examine microhabitat conditions. Wetmore et al. (1990) found Froude number more discriminatory of caddisfly habitat than water depth or velocity. Froude number combined information from both water velocity and depth into a single dimensionless variable, and, importantly, stream areas with the same Froude number have the same flow characteristics even if they have different

combinations of depth and velocity. For example, a patch of habitat with an average flow of 0.2 m/s and depth of 0.4 m has the same flow characteristics as a habitat with an average flow 0.1 m/s and depth of 0.1 m (Figure 3.1).

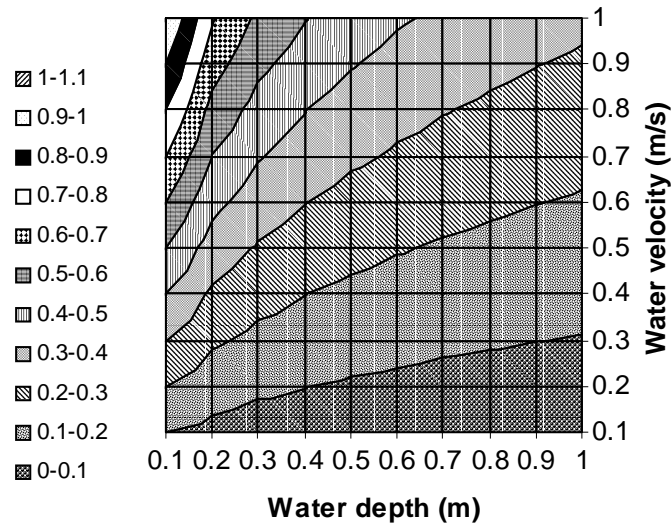

Figure 3.1. Surface plot of Froude number based on typical values for water velocity and water depth measurements in streams. Bands represent similar Froude values and therefore similar water flow characteristics across different combinations of depth and velocity.

Because of its usefulness, Froude number has been used to distinguish among habitat types (Vadas and Orth, 1997), related to fish community structure (Danehy et al., 1998; Lamouroux et al., 1999), and determine relationships of hydraulic habitat to aquatic ecology in many other studies (Bouckaert and Davis, 1998; Vadas and Orth, 1998; Rerrpel et al., 1999; Smith, Unpublished data).

This study tests the relationship of fish morphology to Froude number, using morphological traits identified in the literature as relevant to fish habitat use and swimming performance. Because habitat with similar Froude number will exert similar environmental pressure on body shape, morphology can be expected to be more similar among species occupying areas with similar Froude number. The objective of this study was to test whether or not morphology will be significantly related to habitat use (Froude number) within

ecomorphological guilds.

Methods

Fish collection

Adult fishes from three families (minnows, darters, and suckers) were collected from the North and South Fork of the Roanoke River and the Powell River (Virginia), with a backpack electrofishing unit, anaesthetized with Tricaine methanesulfonate, and then preserved in 10% formalin. For large fishes, greater than 200 mm total length, the abdominal cavity was sliced open to allow penetration of formalin. Fishes remained in formalin for at least five days, washed in water for five days and were then transferred to 50% ethanol for storage. Species and sample sizes are given in Appendix G.

Morphology measurements

Thirty morphology characteristics related to habitat were identified from the literature (Appendix A). Measurements were made on each adult fish using digital calipers to the nearest 0.1 mm except for traits more than 155 mm in length which were measured with metal rulers to the nearest 1 mm. An attempt was made to measure ten individuals of each species. Initial morphology measurements were either standardized to body size (standard length) or used to calculate new shape factors (Appendix A) to create a data set of 40 shape variables for analysis.

Habitat Data

Measurements of simple habitat variables for each species were found in the literature (Temple, 1997; Vadas, 1994; Vadas and Orth, 2000). Habitat use values for Roanoke River fishes were taken as the midpoint of the range of habitat means presented in Table 2 of Vadas (1994), except for blacknose dace and northern hog sucker for which values were taken from Table 3 of Vadas (1994).

Habitat use data for fishes of Powell River were taken from Temple (1997). Temple (1997) sampled microhabitat of fishes using 4 m x 2 m electrofishing grids, four grids per transect, and six transects per site. Riffle, runs, and "head runs" were sampled with grids. Microhabitat

(water depth, water-column velocity, and substrate) was sampled at the four corners of the grids. Substrate was transcribed to the numeric system of Vadas (1994) and then a mid-point of the range was assigned to each species.

Statistical Analysis

Four ecomorphological guilds were used for analysis: benthic darters, benthic minnows, open-water minnows, and open-water suckers. Ecomorphological guilds account for the evolutionary history and lifestyle of fishes, factors that strongly influence fish morphology. All analysis procedures were carried out using Statistical Analysis Software (vers. 7.0, Statistical Analysis Systems Institute, Inc., Cary, NC, unpubl.). Morphology trait measurements from individuals were averaged for each species. Within fish families, correlation analysis was conducted to identify morphology traits describing similar fish features and to reduce the number of variables for further analysis (Appendix G). For variables with correlation coefficients higher than 0.70, only one variable of the pair was kept. Remaining traits were then regressed against Froude number (Fr):

$$Fr = \frac{V}{\sqrt{g \times D}}$$

where V is water velocity (m/s), g is gravity (9.82 m/s^2) and D is water depth (m). Significant regressions were considered to have p-values of less than 0.10.

Results

Correlation analysis was performed by fish family or family sub-group (Appendix G). The following 13 variables were kept for use in regression analysis: axial caudal fin length, caudal fin depth, maximum body depth, total length of dorsal fins, maximum dorsal fin span, caudal peduncle width, pectoral fin length, area of pectoral fin, eye location, distance from pectoral to pelvic fin, caudal peduncle length, distance from posterior of neurocranium to anterior of dorsal fin, and distance from posterior of maxillary to pectoral fin. In addition, several more variables

were kept for open-water minnows, including the following: trunk shape, pectoral fin width (in place of length), maximum body width, eye size, caudal fin length, eye size relative to head depth, ratio of caudal fin depth to maximum body depth, caudal fin aspect ratio, distance from anterior of jaw to posterior of maxillary, distance from anal fin to ventral membrane of the caudal fin, and the distance from pelvic fin to anal fin.

Froude number was calculated for each species based on average habitat use. Significant regressions between Froude number and individual morphology traits are presented in Table 3.1.

Table 3.1. Statistically significant regressions ($p < 0.05$) for morphology traits versus Froude number.

Family (Sub-group)	Hydraulic Variable (Dependent)	Trait ^a (Independent)	p value	Equation	r ²
Minnows (Pelagic)	Froude number	PELAF	0.001	$Y = 1.33 + -6.01(X)$	0.64
Minnows (Benthic)	Froude number	EYELOC	0.04	$Y = -0.14 + 0.49(X)$	0.46
		CPL	0.03	$Y = -0.18 + 1.79(X)$	0.52
		MAXPEC	0.001	$Y = 0.66 + -2.67(X)$	0.80
Darters	Froude number	PECPEL	0.03	$Y = -0.08 + 3.35(X)$	0.37
		CPL	0.01	$Y = 0.68 + -2.03(X)$	0.54
Suckers	Froude number	PFL	0.05	$Y = -0.59 + 4.32(X)$	0.77

^aTrait measurements are defined and illustrated in Appendix A.

For darters, two traits were significantly related to Froude number, caudal peduncle length and the distance between pectoral fin and pelvic fin (both, as percent of standard length). The caudal peduncle length decreased with decreasing Froude number (generally, flows with less velocity) (Figure 3.2). The distance between pectoral and pelvic fins increased with increasing Froude number (generally, higher flows) (Figure 3.3).

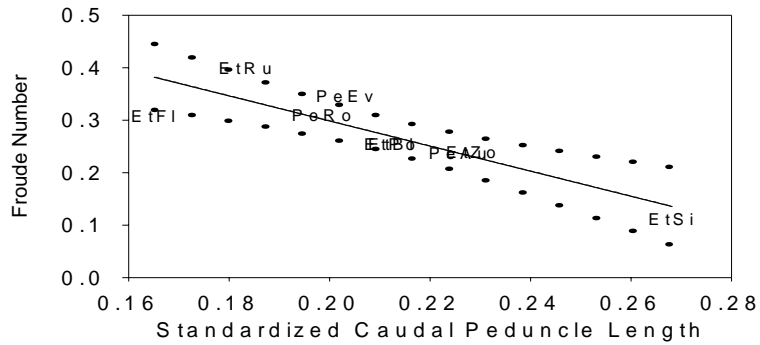

Figure 3.2. Plot of caudal peduncle length (percent of standard length) versus Froude number (from habitat use) for darters ($p=0.01$, $r^2=0.54$). Dotted lines are 95% confidence intervals. Acronyms for species are as follows: PeAu = *Percina aurantiaca*, PeRo = *Percina roanoka*, PeEv = *Percina evides*, PeRe = *Percina rex*, EtFl = *Etheostoma flabellare*, EtPo = *Etheostoma podostemone*, EtBl = *Etheostoma blennioides*, EtRu = *Etheostoma rufilineatum*, EtZo = *Etheostoma zonale*, and EtSi = *Etheostoma simoterum*.

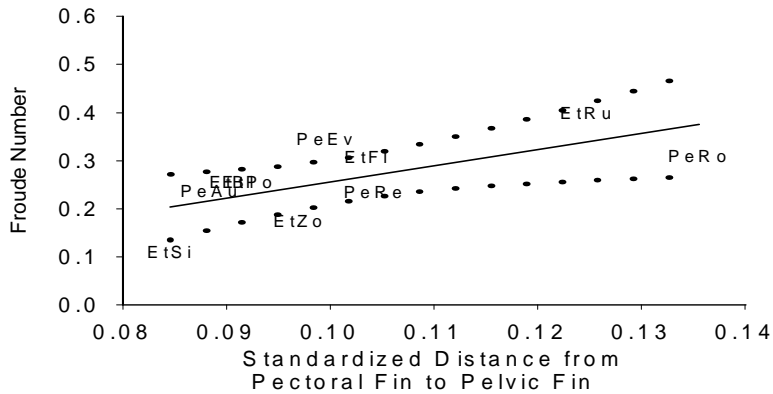

Figure 3.3. Plot of the distance between pectoral fin and pelvic fin (percent of standard length) versus Froude number for average habitat use of darters ($p=0.03$, $r^2=0.43$). Dotted lines are 95% confidence intervals. Acronyms for species are as follows: PeAu = *Percina aurantiaca*, PeRo = *Percina roanoka*, PeEv = *Percina evides*, PeRe = *Percina rex*, EtFl = *Etheostoma flabellare*, EtPo = *Etheostoma podostemone*, EtBl = *Etheostoma blennioides*, EtRu = *Etheostoma rufilineatum*, EtZo = *Etheostoma zonale*, and EtSi = *Etheostoma simoterum*.

Within the group of benthic minnows, the position of the eye on the head, the caudal peduncle length, and the distance from maxillary to pectoral fin were all statistically significant.

The eye was positioned on the head higher in species using habitat with higher Froude numbers, such as riffle species while benthic minnows occupying pools tended to have eyes lower on their head (Figure 3.4). Caudal peduncle length increased with increasing Froude number (more turbulent flows) (Figure 3.5), species occupying riffles or runs having relatively longer caudal peduncle lengths. Finally, the distance from the back of the jaw (posterior of maxillary) to the anterior base of the pectoral fin decreased as Froude number decreased (Figure 3.6). Fishes in riffle and run habitat having a shorter distance from the jaw to the pectoral fin and fishes in pool type habitats having relatively more distance from the jaw to the pectoral fin.

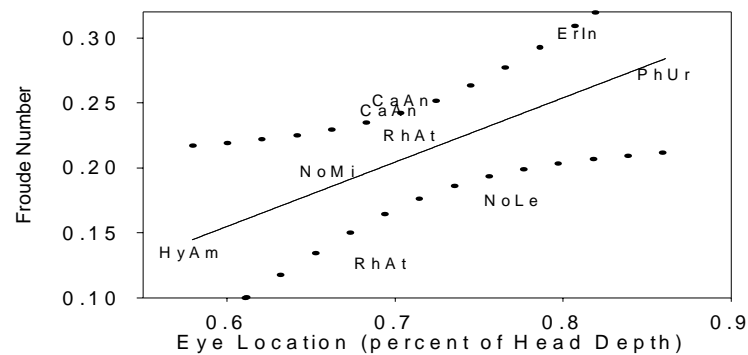

Figure 3.4. Plot of vertical height of the eye on head versus Froude number for benthic minnows ($p=0.04$, $r^2=0.46$). Dotted lines represent 95% confidence intervals. Acronyms are as follows: CaAn = *Campostoma anomalum*, ErIn = *Erimystax insignis*, HyAm = *Hybopsis amblops*, NoLe = *Nocomis leptcephalus*, NoMi = *Nocomis micropogon*, PhUr = *Phenacobius uranops*, and RhAt = *Rhinichthys atratulus*.

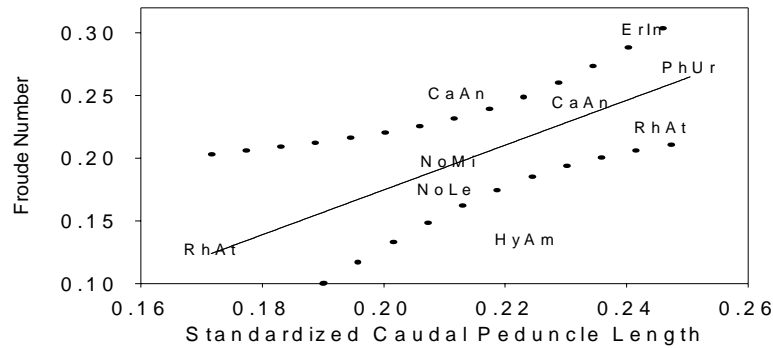

Figure 3.5. Plot of caudal peduncle length (percent of standard length) versus Froude number for benthic minnows ($p=0.03$, $r^2=0.52$). Dotted lines represent 95% confidence intervals. Acronyms are as follows: CaAn = *Campostoma anomalum*, ErIn = *Erimystax insignis*, HyAm = *Hybopsis amblops*, NoLe = *Nocomis leptocephalus*, NoMi = *Nocomis micropogon*, PhUr = *Phenacobius uranops*, and RhAt = *Rhinichthys atratulus*.

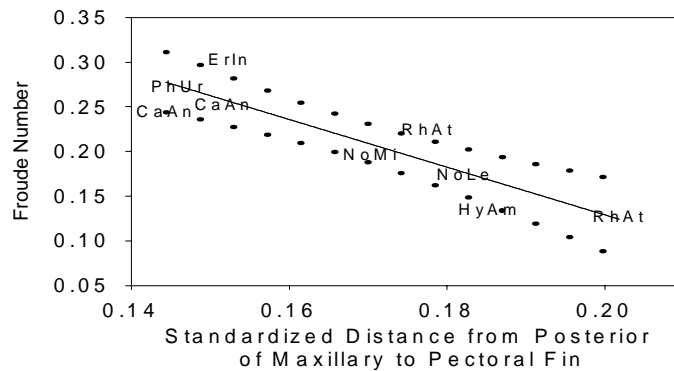

Figure 3.6. Plot of distance from maxillary to pectoral fin (percent of standard length) versus Froude number for benthic minnows ($p=0.001$, adjusted $r^2=0.80$). Dotted lines represent 95% confidence intervals. Acronyms are as follows: CaAn = *Campostoma anomalum*, ErIn = *Erimystax insignis*, HyAm = *Hybopsis amblops*, NoLe = *Nocomis leptocephalus*, NoMi = *Nocomis micropogon*, PhUr = *Phenacobius uranops*, and RhAt = *Rhinichthys atratulus*.

For open-water minnows, the distance from the anterior base of the pelvic fin to the anterior base of the anal fin was the only trait significantly related to Froude number. The distance, relative to standard length, decreases as open-water minnow species use habitats with lower Froude number (Figure 3.7).

The sample of suckers was inadequate to divide among more benthic and open-water oriented species. However, the distance from the anterior base of the pelvic fin to the anterior base of the anal fin was significantly related to Froude number, decreasing as fishes used lower Froude number (habitats with less turbulent surface flows) (Figure 3.8).

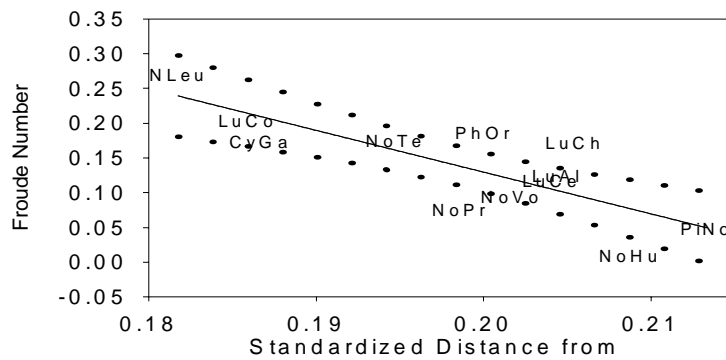

Figure 3.7. Plot of distance from pelvic fin to anal fin (percent of standard length) versus Froude number (from habitat use) of pelagic minnows ($p=0.001$, adjusted $r^2=0.64$). Dotted lines represent 95% confidence intervals. Acronyms are as follows: CyGa = *Cyprinella galactura*, LuCe = *Luxilus cerasinus*, LuAl = *Luxilus albeolus*, LuCh = *Luxilus chrysocephalus*, LuCo = *Luxilus coccogenis*, NLeu = *Notropis leuciodus*, NoTe = *Notropis telescopus*, NoVo = *Notropis volucellus*, NoPr = *Notropis procne*, NoHu = *Notropis hudsonius*, PhOr = *Phoxinus oreas*, and PiNo = *Pimephales notatus*.

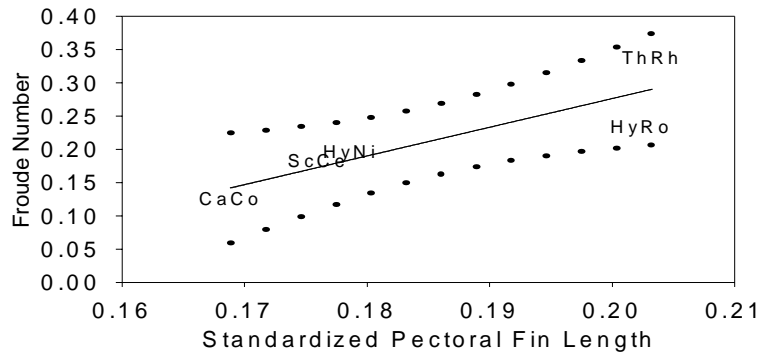

Figure 3.8. Plot of pectoral fin length (percent of standard length) versus Froude number (from habitat use) for suckers ($p= 0.05$, $r^2= 0.77$). Dotted lines represent 95% confidence intervals. Acronyms are as follows: ThRh = *Thoburnia rhothoeca*, ScCe = *Scartomyzon cervinum*, CaCo = *Catostomus commersoni*, HyNi = *Hypentelium nigricans*, and HyRo = *Hypentelium roanokense*.

Discussion

Simple hydraulic variables, such as Froude number, may be readily modeled in available instream flow software (Layzer and Madison, 1995) and their relationships to stream hydrology are well understood (Gordon et al., 1992). Hydraulic variables such as those in this study are typically used in equations related to stream hydrology and have been created to describe conditions of water flow or sediment movement at local and reach scales. Recently aquatic scientists have begun investigating their usefulness at local scales for describing conditions relevant to fish and macroinvertebrate ecology (Layzer and Madison, 1995; Townsend et al., 1997; Vadas and Orth, 1998; Smith, Unpublished data). The relationship of a simple hydraulic variable, Froude number, with fish morphology was investigated across three species.

Froude numbers have generally been used to designate large scale (stream section) flow with Froude number less than one being slow or tranquil flow and Froude values greater than one being super critical (fast or rapid). Typical stream flows are subcritical. On a local scale Vadas and Orth (1998) found Froude numbers useful for distinguishing habitat types with runs having Froude values less than 0.2 and fast riffles having values greater than 0.2. Vadas and Orth (1998) combined Froude number with a water velocity-depth ratio (V/D) to distinguish the position of

slow riffles in a habitat key.

In this study, results indicated that some relationships of morphology and Froude number were not consistent across all groups, even for fishes having similar morphology and occupying the same habitat types. For example, within darter species caudal peduncle length decreased Froude number increased (more turbulent flow, water velocity increasing, riffles) while in benthic minnows caudal peduncle length increased as Froude number increased. These results are consistent with studies that have concluded that the evolutionary history, i.e., phylogeny, of species does not allow transferability of relationships across certain phylogenetic distances, e.g., families, (Felley, 1984; Douglas and Matthews, 1992). When examining relationships of morphology and habitat use, morphology will be most useful within lower phylogenetic levels (Felley 1984, Wood and Bain 1995); generalizations across families may be invalid.

Unfortunately there is little theoretical foundation of morphology-hydraulic interactions for benthic fishes, which makes interpretation of different trends across fish families difficult. However, differences in caudal peduncle shape and length are known to be important attributes related to swimming ability (Bandyopadhyay and others, 1997). Some observations of darter habitat use, suggest they select habitat at a very small scale, certain species occurring between rocks, in the open, or on top of rocks (Welsh and Perry, 1998a). Preferences like these will certainly have implications for small morphological adaptations to the hydraulic conditions they experience, and may explain variation in morphology-hydraulic habitat associations across families. Also, habitat data used in this study was at the habitat-patch scale. A more refined data set with higher resolution of measurements for habitat use and measurements of individuals using those habitats will likely lead to better interpretation of morphology-habitat associations.

The shorter caudal peduncle of darters using more complex flow areas (higher Froude) probably allows darters to create more powerful short bursts of speed necessary to move about in higher velocities. Species that specialize in burst swimming typically have an anal fin positioned farther back the body creating a short caudal peduncle length, like a pike (Webb 1984). It would be interesting to have measurements of burst power for the different species and then determine their maximum distance per movement. My interpretation for caudal peduncle length is that darter species with longer caudal peduncle living in pools are adapted to making longer

movements per movement. I also interpret the relationship of increasing distance between pectoral and pelvic fins with Froude number to indicate deeper bodied darter species, i.e., more robust species, occupy more turbulent flows.

For benthic minnows, species occupying riffles had eyes positioned higher on their head, which may help them visualize a more complete picture of overhead objects and identify the presence of predators, such as wading birds. Also, the two species using the shallowest habitat had the most benthic-oriented mouths with sensitive lips for helping them taste prey (Jenkins and Burkhead, 1994). Therefore, sight could be devoted more to other tasks such as predator avoidance. On the other end of the relationship, species in pools had eyes that were almost centered in their head depth. This position allows them to effectively see almost equally above and below them while having the visual field more centered on lateral spaces.

The relationship of caudal peduncle length to habitat for benthic minnows was positive as opposed to the negative relationship for darters. Caudal peduncle length is a measurement based on the position of the anal fin. This relationship means that the anal fin is more forward on benthic minnows on riffles. Based on my review of the literature I have no explanation for why this would be advantageous to riffle species.

Finally, benthic minnows in riffles had a shorter distance from the posterior of the jaw to the pectoral fin than benthic minnows in pools. It is possible this association was because pectoral fins were more forward on species living in areas with more turbulent flow conditions. Pectoral fins are thought to be used by some benthic species for holding position, although at least one study questions this hypothesis (Matthews, 1985). Alternatively, species could have changes in jaw length, species in areas with higher Froude number having larger mouths to feed on larger bodied prey items found in these areas, such as mayflies, caddisflies, and stoneflies. Further, my two explanations are not mutually exclusive; both could be occurring with a net overall result of having a shorter distance in stronger riffles.

The only relationship statistically significant for pelagic minnows was that of the distance between pelvic fin and anal fin. Shorter distances were observed in fishes living in areas of higher Froude number (more turbulent areas). The combination of pelvic fins and anal fin on pelagic species may be equivalent to a system of stabilizing fins and a rudder. Moving the two closer

together can provide for better control over rapid movements and changes in direction in the varying flow conditions of higher Froude number. Alternatively, under conditions of low Froude number, species may streamline for less resistance to motion. Streamlining includes a lengthening of the body which would separate the pelvic and anal fins.

Finally, species of catostomids in riffle habitat (high Froude number), had relatively longer pectoral fin lengths than species in pool conditions. Species in riffles were also more benthic in nature, having larger more robust pectoral fins than open-water suckers. Benthic species do rest their pectoral fins on the bottom, possibly to grip substrate as a means to hold position or to use as hydrofoils, which use water flow to create pressure that pushes their bodies against the bottom, aiding in maintaining position (Matthews, 1985). The open-water species of suckers do not have similar use for large robust pectoral fins which could add considerable resistance to swimming. Suckers in pool habitats (low Froude number) did have smaller pectoral fins.

Another observation worth noting is that of the habitat-morphology relationships for blacknose dace and central stonerollers, the two species with observations on two rivers. Blacknose dace from the Roanoke River occupied different habitat than with those from the Powell River. Blacknose dace in the Powell River used shallower, slower water (Froude value near 0.12) than those from the Roanoke River (Froude number near 0.22). Individuals measured from the two rivers also had morphological differences which were consistent with the trends plotted for other benthic minnows. Therefore, despite being members of the same species, morphological changes were consistent with changes in habitat use among the rivers. Additionally, these observations are consistent with the fact that the two rivers contain different subspecies, the eastern blacknose dace (*Rhinichthys atratulus atratulus*) in the Roanoke River and the western blacknose dace in the Powell River (*R. atratulus obtusus*) (Jenkins and Burr, 1994). On the other hand, in the upper Tennessee, Roanoke and New Rivers, central stoneroller are considered a single subspecies (Jenkins and Burkhead, 1994). Central stonerollers from the Roanoke and Powell River had similar habitat use and both plotted similarly in their morphology for the three relationships of this study. Results with central stonerollers and blacknose dace suggest that morphology may be accurate in describing differences in habitat use, possibly even among subspecies. Future work examining variation in individuals versus their microhabitat use

would be helpful in determining if these relationships are sufficiently strong for making ecological predictions at the level of populations.

Results of this study demonstrate that simple hydraulic variables have relationships to individual morphology traits. Although not tested in this study, these relationships should be more transferable than similar relationships developed for water velocity. This study used average morphology trait conditions and average habitat use conditions; a data set with measurements of individual fish and their focal habitat use was not available. Because relationships were at the coarsest scale of species and average habitat use, data sets of individual fishes and their focal habitat use may improve the strength of some relationships. In addition, relationships were present for all benthic species while using depth-average velocity. For benthic species, demersal velocities would better describe local flow conditions and I anticipate analysis with demersal velocities will strengthen relationships between habitat variables and morphology. Also, the relationships identified in this study were of simple-linear form, suggesting that multivariate assessment of morphology-habitat relationships may not be necessary in all cases.

The habitat metrics I suggest, simple hydraulic variables, more thoroughly describe habitat use, are transferable among study sites, and have direct meaning to stream hydrology. New metrics for describing spatially varying flows have recently been tested with two-dimensional flow models (Crowder and Diplas, 2000). These hydraulic models have the potential to describe spatially explicit energy gradients by describing velocity gradients (Crowder and Diplas, 2000). Therefore, hydraulic variables are appropriate for describing physical processes directly related to habitat use by fishes and other aquatic organisms. They should allow biologists to strengthen the understanding of constraints on habitat use for fishes and create a stronger foundation for assessing habitat changes in streams. Hydraulic variables should be considered as alternatives to traditional methods of assessing fish habitat use.

Chapter 4. Ecomorphological relationships of warmwater stream cyprinids, linking morphology, swimming performance, and habitat preference.

Abstract

This study evaluated links among fish morphology, swimming performance (critical swimming speed) and habitat use of eight cyprinids from the Roanoke River, Virginia. Mean swimming ability ranged from 45.7 cm/s - 59.8 cm/s for eight cyprinids ranging in mean total length from 6.2 cm to 11.5 cm, while swimming at mean water temperatures of 16.1-20.5°C. The performance of all species averaged six body lengths per second. Species of higher swimming ability also were reported to use habitats with higher mean water velocities and Froude numbers, although relationships were not statistically significant ($p=0.07$ and $p=0.12$, respectively). Habitat use as reported in the literature was approximately 60% of swimming performance for six rheophilic species, but not for two pool species that used velocities well below critical swimming speed. The 60% performance threshold was near the theoretically optimal swimming speed, i.e., efficient, swimming speed of each species based on body size, which suggested that energetic considerations were important for microhabitat selection. Further, this study tested relationships of five morphological traits to swimming performance. The aspect ratio of the caudal fin was the only trait significantly related to swimming performance of species ($p=0.05$, $r^2=0.56$). Results of this study then suggest that morphological traits may be used to predict swimming ability, which provided both an upper limit to usable water velocities and an index to preferred water velocities. Further, because swimming ability was related to habitat use, morphology measurements may be able to predict habitat preferences.

In summary, this study suggests that habitat use thresholds may be developed based on body shape for closely related species and validated with swimming speeds measured in the lab. Predictions of habitat use based on morphology are adequate for classifying species into habitat guilds.

Introduction

Lotic environments have been altered in many ways by human use of watersheds (Collier et al., 1996; Walser and Bart, 1999; Stancil, Unpubl. data). Urbanization, flood control, and agricultural practices have changed stream hydrology, increasing peak flow rates and decreasing the period over which those flows were reached (Pizzuto et al., 2000). The use of culverts in road construction and the placement of weirs changed local flow patterns which fragmented stream habitat by preventing fish from moving among stream reaches (Warren and Pardew, 1998). These changes represented pervasive, permanent and unnatural conditions for stream environments. In order to conserve, mitigate or restore lotic environments for aquatic fauna, in particular fishes, a better understanding of habitat as related to changes in stream flow are needed. For fishes, understanding the physical limits of swimming ability will help improve culvert design to prevent stream fragmentation and increase understanding of habitat preferences (Warren and Pardew, 1998; Facey and Grossman, 1990).

For fishes, swimming performance measurements have successfully predicted entrainment (Hartwell and Otto, 1978), habitat preferences (Matthews, 1985; Facey and Grossman, 1990, 1992), and impassable water velocities (Mesa and Olson, 1993; Adams et al., 2000). Warren and Pardew (1998) stated that determining critical water velocities (limits of swimming performance) was a key requirement for improving road-crossing designs and fish passage in small streams. Swimming performance was also a major consideration in fishway design for other structures such as dams and weirs (Adams and Parsons, 1996; Peake et al., 1997).

Measurements of swimming performance have many purposes, but a number of factors need consideration when taking these measurements. Factors affecting swimming ability include type of locomotion, fish size, shape, physiology(temperature), and behavior (Beamish, 1975; Videler and Wardle, 1991; Hammer, 1995).

Swimming ability of fishes depends first on type of locomotion, body size and then shape. Fishes typically specialized on of three types of swimming, cruising, accelerating, or maneuvering (Webb, 1984). Swimming performance also increased with increasing length of most fishes (Hammer, 1995; Parsons, 1990); larger species achieved higher speeds than smaller species and large individuals swim faster than small individuals of the same species. When swimming ability

was adjusted for size, shape becomes the most important factor determining performance among species. Therefore, to compensate for length differences between individual fish, it was standard to convert water velocities to fork length/second (FL/s) or body length/second (BL/s) (Mesa and Olson, 1993). Temperature and photoperiod also interacted with swimming performance (Hammer, 1995; Smiley and Parsons, 1997). Other factors affecting swimming performance included pH (Nelson, 1989), gender and adult sexual condition (Williams and Brett, 1987), rearing environment (Duthie, 1987; Williams and Brett, 1987) and trials of individuals versus groups (Hartwell and Otto, 1978; Boyd and Parsons, 1998).

Swimming activity of fishes has been commonly classified as burst, prolonged, and sustained (Beamish, 1978; Jones, 1992). Burst speeds were rapid movements of short duration, usually less than 2 min, with energy mostly being supplied from anaerobic processes. Prolonged swimming activity included speeds that last between 2 min and 200 min and ended in fatigue when maintained (Beamish, 1978; Jones, 1992). Energy for prolonged swimming activity came from both aerobic and anaerobic processes (Jones, 1992). Sustained activity was a swimming speed that could be maintained for longer than 200 min and was supplied with energy from aerobic processes.

In order to compare swimming speeds among fishes or individuals, critical swimming speed (U_{crit}) was calculated (Matthews, 1985; Taylor and Foote, 1991; Mesa and Olson, 1993) as:

$$U_{crit} = u_1 + \left(\frac{t_1}{t_2} + u_2 \right)$$

where u_1 was the highest speed (cm/s) maintained for an entire period, t_1 was the time the fish swam in the fatigue period (min), t_2 was length of swimming periods (min), and u_2 was the increase in water velocity speed (cm/s) between periods. Traditionally swimming activity was measured in a stepwise fashion with velocity steps between swimming periods being 10 cm/s (Beamish, 1978). However, recent research has suggested that a ramping velocity method may be used to both acclimate fish to the swim tunnel and skip early steps of low velocities that fish should be able to complete (Jain et al., 1997). This method saved trial time, thereby allowing increased sample sizes. Because swimming performance of fishes can have substantial individual

variation, increasing sample size was important. Additionally, critical swimming speeds were a threshold between energetic states and represented real biological consequences for fishes. If water velocity exceeded swimming ability, a fish fatigued and could not hold station to use a habitat, fatigue being the threshold between sustainable aerobic respiration and non-sustainable anaerobic cellular respiration. Therefore, swimming performance may determine whether or not fish have access to habitat resources (Warren and Pardew, 1998; Toepfer et al., 1999; Adams et al., 2000).

For some fishes, swimming ability has been measured and used to evaluate weir and culvert design to reduce their detrimental impacts on fish movement (Adams and Parsons, 1996; Peake et al., 1997; Toepfer et al., 1999); these species tended to be large, migratory fishes important to commercial or recreation activities. Performance measurements have not been made for as many nongame fishes despite the fact they represented a greater portion of aquatic diversity than commercial or recreational species. In fact, the existence of many small, nongame fishes, e.g., many minnows and darters, were threatened by human induced impacts to the stream environment (Adams et al., 2000; Warren et al., 2000). For nongame fishes, a better understanding of habitat preference would allow restoration, conservation or protection from changes in stream flow.

A large body of research has been conducted on fish swimming performance and the theory of swimming mechanics has been well established as a research field (Videler, 1993; Hammer, 1995; Triantafyllou et al., 2000). This knowledge has been used to predict limits to swimming ability of large (> 20 cm) oceanic and anadromous riverine species (Sambily, 1990), but little of it has been transferred toward predictions of swimming ability of smaller stream fishes. Hence, morphological studies of habitat use and swimming ability may provide ecomorphological indices that predict usable habitat for small fishes.

Ecomorphological approaches assume that morphology limits the ability of organisms to cope with important activities in their daily life (Wainwright, 1991). An ecomorphology study correlated patterns of ecology with patterns of morphological variation, but this transition from correlation to a causal relationship required evidence that differences in morphology created differences in functional ability and consequently ecological differences in trophic resource use

(Norton, 1995). For example, the capture success of elusive prey types was related to mouth size in cottids (Norton, 1995).

Wainwright (1991) provided a methodology for a research approach to do this. In his experimental sequence, lab tests were first performed on the effect of morphological variation on activity performance because performance defined the potential niche for resource use of the organism. In the second step, the potential resource use was compared to actual use or realized niche. This comparison quantitatively assessed the significance of the organism's maximal activity performance in determining actual resource use.

Based on previous research of morphology and habitat use, morphology can predict some aspects of habitat use (Felley 1984; Douglas and Matthews, 1992; Wood and Bain, 1995). However, this was not truly a test of the relationship between morphology and ecology with respect to performance (function). For fishes, swimming is a key daily task. Swimming performance can limit habitat use and some relationships between swimming and morphology have already been described (Sambily, 1990; Bandyopadhyay et al., 1997; Gerstner, 1999). Therefore the relationship between swimming performance and morphology is an appropriate way to examine functional anatomy of fishes.

Relative to fish morphology, swimming performance depended on the relationship between drag experienced and the thrust a fish produces (Videler, 1993); thrust produced depended on fish morphology. For example, the caudal fin aspect ratio (Sambily, 1990) was an important indicator of swimming ability among species because it related the amount of thrust and drag reduction of the caudal fin while in motion (Videler, 1993). The aspect ratio was the height of the caudal fin squared over the surface area of the fin. Also, the overall shape of a fish contributes to drag reduction (Sagnes et al., 1997) and recent research suggested that drag coefficients for fishes may predict swimming performance (P. Sagnes, personal communication). Because swimming performance has a maximum physical limit and depended upon environmental conditions, it was useful for defining the potential habitat.

Despite the biomechanical connections among fish morphology, swimming ability and habitat use, surprisingly, little work has been done to use the relationship of morphological indices of swimming ability to predict habitat use for nongame fish species. In this study, I set out to

determine and compare swimming performance among several cyprinids common to the upper Roanoke River (VA), examine relationships of swimming performance to habitat use, and determine if gross morphology was indicative of swimming ability. Specifically, I wanted to test the hypotheses that cyprinids inhabiting habitats of higher water velocities would have increased swimming performance, and cyprinids inhabiting higher water velocities would have morphological adaptations for improved swimming performance that could be used to identify habitat preference.

Methods

For this study, cyprinids were chosen as target taxa because (1) cyprinids are key species in fish communities of the upper Roanoke River (VA) and represent a significant portion of fish diversity in Virginia, (2) there exists a sufficient number of species within the watershed for statistical analysis, (3) cyprinids inhabit all but one habitat type (fast riffles) in the river, (4) cyprinids exhibit a wide variety of body shapes, and (5) little is known about cyprinid swimming performance. This study examined the swimming performance of *Notropis hudsonius* (NoHu), *Clinostomus funduloides* (ClFu), *Luxilus cerasinus* (LuCe), *Nocomis leptcephalus* (NoLe), *Luxilus albeolus* (LuAl), *Phoxinus oreas* (PhOr), *Lythurus ardens* (LyAr), and *Campostoma anomalum* (CaAn).

From June to December, 1999, adult cyprinids were captured in the field with a minnow seine, brought to the lab, and held in a Living Streams model 510 tank. The tank was divided into two sections and water temperature was controlled with a chilling unit set to match stream temperature at the time of capture. Two fluorescent lights were suspended 90 cm above the tank and set to match sunrise and sunset at the time of collection. Fish were fed once daily, *ad libum*, Tetra tropical fish flake and mini discus food. Fish were allowed to acclimate to the holding tank 24 hours before use in swimming trials and were not fed for 24 hrs, pre-trial, to obtain a post-absorptive state for swimming trials.

All swimming trials were performed in a Blazka type swim tunnel (Blazka et al., 1960). Dimensions of the outer chamber are 40 cm width X 120 cm length X 41 cm high. A variable-speed motor (0.75 h.p., 2500 rpm) with rheostat control was used to drive an aluminum, 14.6 cm

propeller. The propeller forced water down a 15 cm diameter acrylic tube through a flow filter which encourages a rectilinear plane of uniform micro turbulence (discouraging a parabolic flow profile due to boundary layers) (Beamish, 1978). The flow filter was constructed from drinking straws (6mm diameter x 68 mm length) glued into a “honeycomb” grid with silicone sealant. Tap water was used in all experiments. It was aerated for at least 48 h prior to trials in a 300-l reservoir tank and temperature was controlled via a chilling unit set to match holding tank temperature and, hence, stream conditions.

For swimming trials, a modified protocol of the ramp-critical swimming speed was used (Jain et al., 1997). An individual fish was removed from the holding tank and placed into the swim tunnel. The fish was allowed to acclimate for a minimum of 0.75 h under minimal flow (10 cm/s), enough to encourage orientation. During transfer, fish size (total length) was estimated; this estimate was used to determine the maximum practice velocity. Jain et al.(1997) used 75% of fork length as the starting point for their ramp-performance experiments because as a rule of thumb fatigue occurs at or below 10 body lengths per second for fishes. The maximum practice velocity (cm/s) of this study was conservatively set at 50% of total length. Tunnel water velocity was increased in 5 cm/s increments, every two minutes, until the fish completed swimming at the maximum practice velocity. Water velocity was then decreased to the acclimation velocity (10 cm/s) and the practice run repeated. The fish was then allowed to rest for 30 min at the acclimation velocity.

After the rest period, swim performance periods began. Water velocity was raised steadily until the maximum practice velocity was reached. The fish was then swum at the maximum practice velocity for 30 min and water velocity was increased 10 cm/s every 30 min until fatigue. Fatigue occurs when the fish allows itself to become entrained against the rear swim chamber screen and fails to resume swimming after stimulation.

At any time during practice or performance swimming periods if the fish attempted to rest on the rear chamber screen it was encourage to continue by hard tapping against the screen with a dip net handle. If a fish did not complete the first 30 min period, it was considered a non-performer. If it completed the first 30 min period, it was included in swimming speed calculations. No correction for blocking effects was made because fish cross-sectional area was

less than 10% of the swim chamber cross-sectional area. Critical swimming speeds were then calculated for each individual using the equation of Beamish (1978). I attempted to record performance measurements for 15 individuals of each species.

Morphology measurements for each species were collected on ten or more adult fish not in swimming trials using digital calipers to the nearest 0.1 mm. The following morphology measurements were collected: distance between pelvic and anal fins, distance between pectoral and pelvic fins, trunk streamlining index (Aleev, 1969), and caudal fin aspect ratio. Morphology measurements were either standardized to body size (standard length) or used in ratios. The caudal fin aspect ratio was calculated as length of fin divided by its depth and Aleev's trunk streamlining index is the distance from the most anterior point of the fish to the maximum body depth divided by standard length (Aleev, 1969).

In this study, I employed three measures of habitat use based on the data of Vadas and Orth (2000). From figures of the range of mean water velocities used by each species, I determined both the mid-point of these mean water velocities and the maximum mean velocity observed during their study (across two years and six sites). Finally, I calculated the Froude number (Fr) for average habitat characteristics. Froude number describes bulk flow characteristics better than simple habitat variables alone (Gordon et al., 1992) and is more transferable among streams than simple habitat descriptors. Froude number was calculated using the following equation:

$$Fr = \frac{V}{\sqrt{g \times D}}$$

where V is average water column velocity (m/s) of habitat, g is gravity (9.81 m/s²) and D was average water depth (m) of habitat.

Vadas and Orth (2000) collected fishes in microhabitat quadrants over two years, during warmer seasons at six stations in the upper Roanoke River, Virginia. Fish and microhabitat samples were taken within mesohabitat units using quadrats that were approximately 20-50 m² in surface area. Fish species (all life stages except fry) were sampled with a seine net and electrofishing (stream side generator) above a block net. Species densities were used to establish

fish-habitat relationships. Quadrat size varied with the homogeneity of hydraulic and channel roughness characteristics. Quadrats taken in rapidly varying areas such as riffles had smaller areas and those in more uniform sections such as pools employed larger areas. Each station had 42 to 80 quadrat samples, which sampled approximately 20% of the area of each mesohabitat unit at a station. Within each quadrat, water depth and water-column velocity (0.6 depth) were determined for three locations along a diagonal from one corner to another (Vadas and Orth, 1997). Values for calculating Froude number for habitat patches were taken as the midpoint of the range of habitat use means reported in Vadas and Orth (2000) for the two years.

For statistical analysis, a three-factor, linear mixed model was used to determine if there were significant differences in swimming performance among species, the effects of length, and the effects of temperature on swimming performance. The GLM procedure from SAS (vers. 7.0, Statistical Analysis Systems Institute, Inc., Cary, NC, unpubl.) was used for this analysis. Within GLM, the LSMEANS option was used to examine differences among mean swimming ability, adjusted for the covariates temperature and fish length. Additionally, for seven species where morphology data was available, mean swimming speed (body length/s) was regressed against morphology using the REG procedure in SAS (vers. 7.0, Statistical Analysis Systems Institute, Inc., Cary, NC, unpubl.). Significant regressions were considered to have p-values of less than 0.05. Swimming speed was also regressed against microhabitat use (maximum mean velocity used and average Froude number) where habitat data was available from the literature. Significant regressions were considered to have p-values of less than or equal to 0.05.

Results

Swimming performance for eight minnow species was recorded (Table 4.1). Mean critical swimming speeds, unadjusted for body size or water temperature, ranged from 45.8 to 60.7 cm/s. Swimming speeds plotted against fish length and water temperature are plotted for all fish (Figure 4.1) and plots of swimming ability versus water temperature within species with more than two observations are given in Figures 4.2 to 4.6. Critical swimming speeds exceeded the mid-point of reported habitat means used. The reported use of water velocities ranged from 5% to 62% of swimming speed (Figure 4.7). Swimming speeds exceeded the maximum mean water velocities

used with the maximum velocity ranging from 11% to 74% of swimming performance (Figure 4.7).

There were no significant interactions detected among species, fish length, and water temperature, therefore a general linear model was run with only main effects to test for significant differences among main effects. Two main effects were significant (fish length, p -value < 0.0004, and water temperature, p -value < 0.0008) while differences in swimming ability among species were nearly significant (p -value = 0.07).

Table 4.1. Mean swimming performance of eight cyprinids from the upper Roanoke River, Virginia. Mean swimming speed calculated with average fish length (8.3 cm) and mean water temperature (16.9 °C) as covariates are reported as Adjusted U_{crit} . One standard deviation (italics) is reported below mean swimming performance, total length, and temperature. *Clinostomus funduloides* and *Luxilus cerasinus* were the only pair to have statistically different means (p-value=0.04) using pairwise comparisons of adjusted mean swimming performance.

Species	Fish (#)	Temperature (° C)	U_{crit} (cm/s)	Total Length (cm)	Adjusted U_{crit} (cm/s)	95% Confidence Limits (cm/s)	
<i>Campostoma anomalum</i>	1		60.7	10.6			
<i>Clinostomus funduloides</i>	11	17.1 <i>1.1</i>	59.8 <i>9.7</i>	9.4 <i>0.8</i>	55.9	49.8	62.0
<i>Luxilus albeolus</i>	20	15.5 <i>4.3</i>	51.4 <i>11.9</i>	9.6 <i>1.6</i>	49.0	43.9	54.2
<i>Luxilus cerasinus</i>	19	16.1 <i>3.9</i>	46.9 <i>14.3</i>	9.1 <i>1.4</i>	45.4	40.7	50.1
<i>Lythrurus ardens</i>	13	18.0 <i>2.1</i>	50.2 <i>11.3</i>	7.4 <i>0.6</i>	52.2	46.5	58.0
<i>Nocomis leptocephalus</i>	2		57.0	11.6			
<i>Notropis hudsonius</i>	2		45.8	7.3			
<i>Phoxinus oreas</i>	17	18.5 <i>1.3</i>	45.7 <i>9.1</i>	6.2 <i>0.8</i>	51.3	44.7	57.9

Table 4.2. Results of regressions of swimming performance against morphological traits or habitat use. Swimming performance was not adjusted for water temperature. Body length per second was calculated as mean performance divided by mean body length for each species.

Morphology Trait or Habitat Variable	Swimming Performance			
	standardized (body length/s) p-value	r^2	unstandardized (cm/s) p-value	r^2
Morphology (7 Species)				
Trunk Shape (Streamlining)	0.16	0.34	0.64	0.04
Maximum body depth	0.33	0.18	0.76	0.02
Distance from pelvic fin to anal fin	0.55	0.07	0.33	0.18
Distance from pectoral fin to pelvic fin	0.08	0.49	0.51	0.09
Caudal fin aspect ratio	0.42	0.13	0.05	0.56
Habitat (6 Species)				
Maximum mean water velocity used	0.49	0.12	0.07	0.57
Froude number	1.00	0.00	0.12	0.48

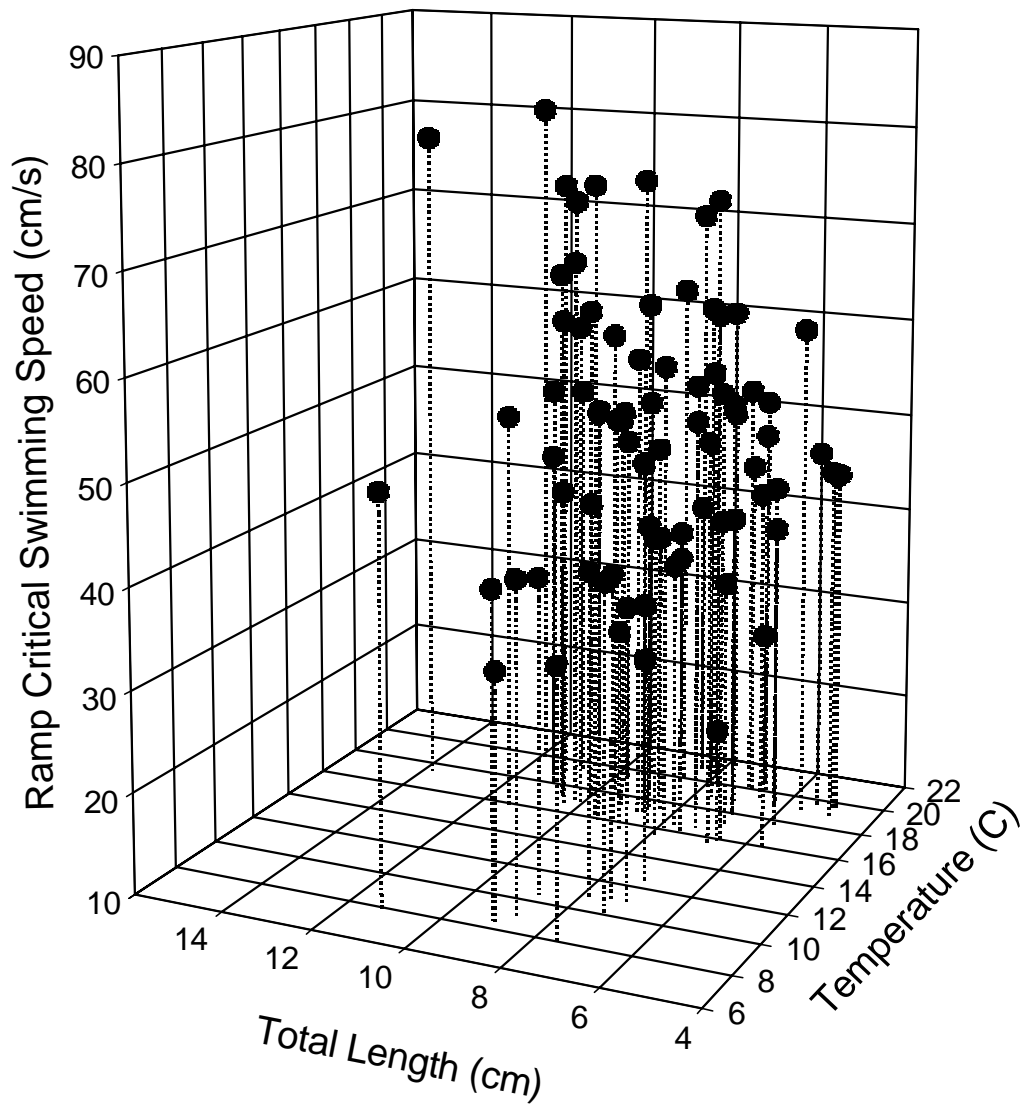

Figure 4.1. Plot of critical swimming speed against length of individual and trial temperature for eight species of minnows: *Noturus hudsonius* (samples=2); *Clinostomus funduloides* (samples=11); *Luxilus cerasinus* (samples=19); *Nocomis leptocephalus* (samples=2); *Luxilus albeolus* (samples=20); *Lythurus ardens* (samples=13); *Phoxinus oreas* (samples=17); *Camptostoma anomalum* (samples=1).

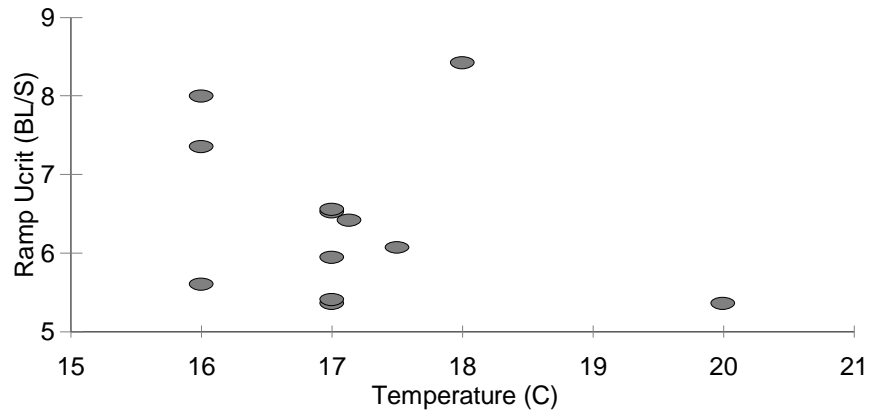

Figure 4.2. Swimming ability of *Clinostomus funduloides* versus water temperature (° C).

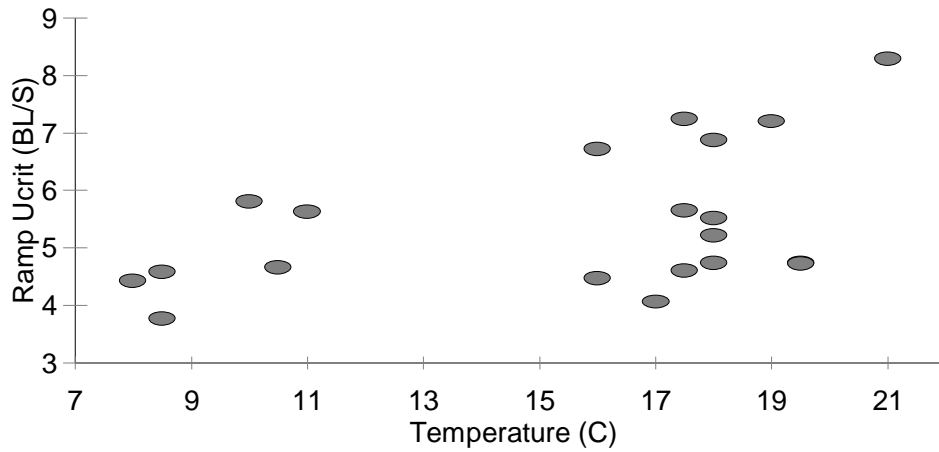

Figure 4.3. Swimming ability of *Luxilus albeolus* versus water temperature (° C).

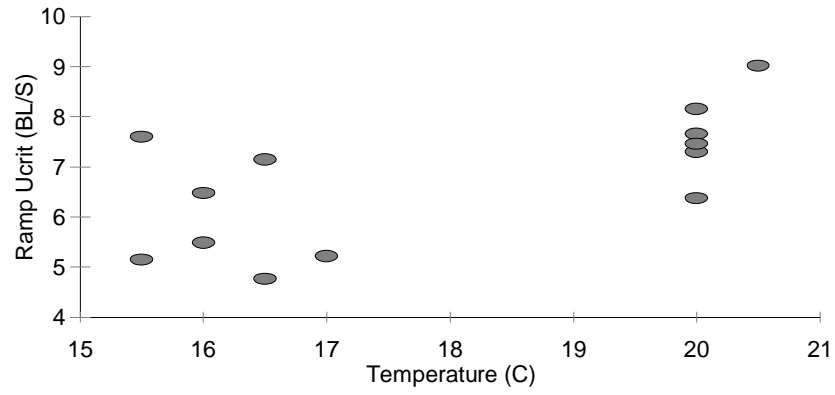

Figure 4.4. Swimming ability of *Lythrurus ardens* versus water temperature (° C).

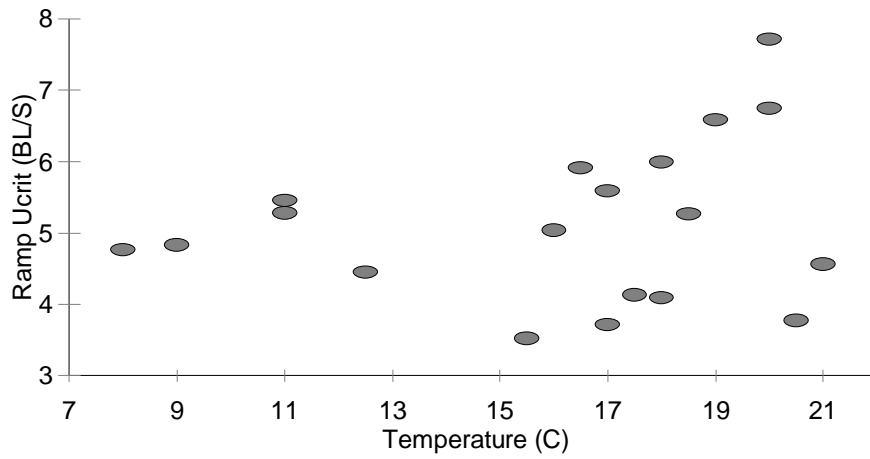

Figure 4.5. Swimming ability of *Luxilus cerasinus* versus water temperature (° C).

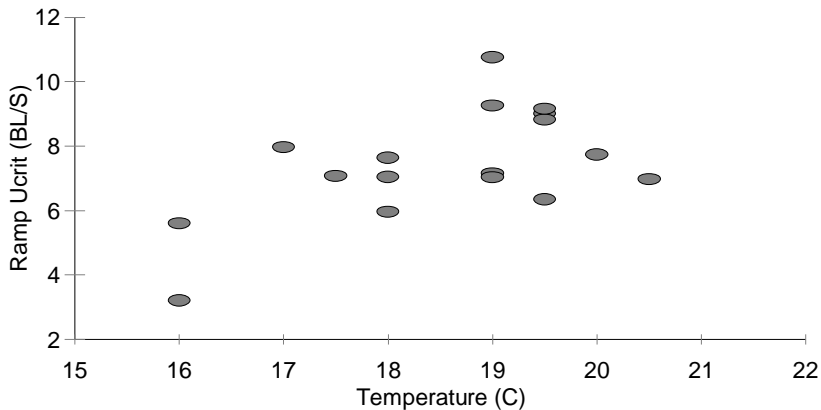

Figure 4.6. Swimming ability of *Phoxinus oreas* versus water temperature ($^{\circ}$ C).

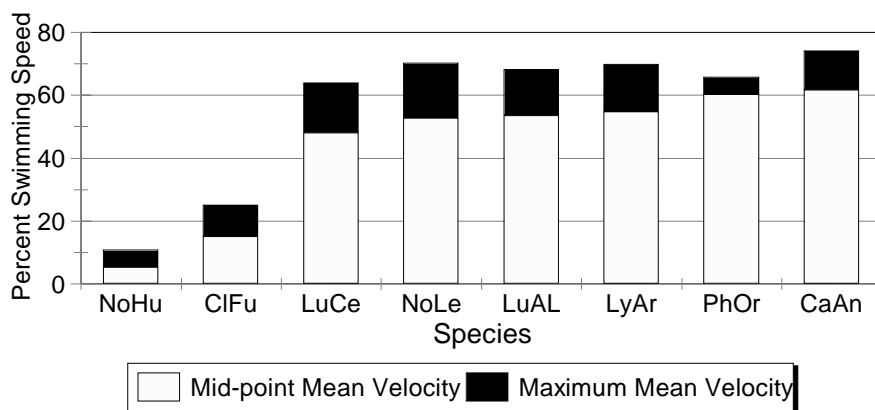

Figure 4.7. Average habitat use as reported in literature relative to swimming ability. The mid-point mean velocity represents the middle of the range of mean velocities observed for each species over two years and several sampling sites (Vadas and Orth 2000). The maximum mean velocity was the maximum velocity reported for the same data (Vadas and Orth 2000). Habitat data for rosyside dace was provided by Facey and Grossman (1992). Acronyms are *Notropis hudsonius* (NoHu), *Clinostomus funduloides* (ClFu), *Luxilus cerasinus* (LuCe), *Nocomis leptocephalus* (NoLe), *Luxilus albeolus* (LuAL), *Phoxinus oreas* (PhOr), *Lythurus ardens* (LyAr), and *Campostoma anomalum* (CaAn).

In general, large fish swam faster than small fish, and fish in warm water swim faster than fish in cold water. Standard deviations around mean swimming ability, unadjusted for

temperature and fish length, were 16-30% of the mean for all species (Table 4.1). Analyses of pairwise differences using mean swimming performance, adjusted for temperature and fish length, found significant differences between only *Clinostomus funduloides* and *Luxilus cerasinus* (p-value=0.04) (Table 4.1). *Clinostomus funduloides* swam faster than similarly sized *L. cerasinus*.

When swimming performance was regressed against reported habitat use and morphology traits, one significant (p-value=0.05) and two nearly significant regressions (p-value < 0.10) were found (Table 4.2). Maximum water velocities occupied in streams were related with absolute (unadjusted for body size) critical swimming speed (Figure 4.8); fishes capable of faster swimming had been reported to use higher water velocities. Relative swimming ability (speed in body lengths/s) was related to the distance between pectoral and pelvic fins (Figure 4.9) such that fishes with shorter distances between fins were generally faster swimmers per body length. This distance represents better hydrodynamic design as expressed through body height. Caudal fin aspect ratio was related to critical swimming speed (cm/s), unadjusted for fish length (Figure 4.10) such that fishes with caudal fins shaped more like a square demonstrated poorer swimming ability.

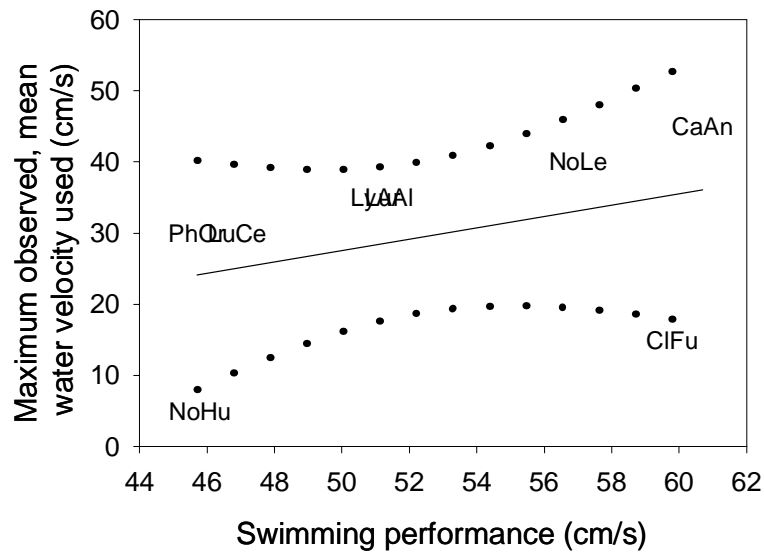

Figure 4.8. Plot of swimming performance versus maximum mean water velocity used as reported in the literature for *Notropis hudsonius* (NoHu), *Clinostomus funduloides* (CIFu), *Luxilus cerasinus* (LuCe), *Nocomis leptocephalus* (NoLe), *Luxilus albeolus* (LuAl), *Phoxinus oreas* (PhOr), *Lythurus ardens* (LyAr), and *Campostoma anomalum* (CaAn).

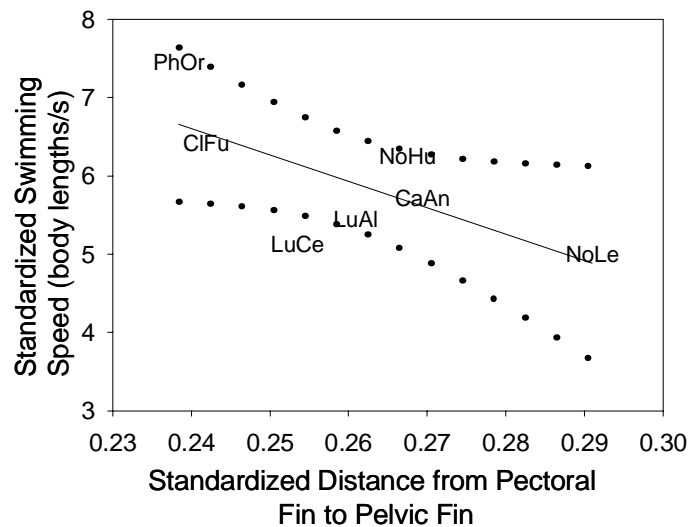

Figure 4.9. Plot of the distance from pectoral fin to pelvic fin (standardized to standard length) versus swimming ability (body lengths/sec) for seven minnows, including *Notropis hudsonius* (NoHu), *Clinostomus funduloides* (CIFu), *Luxilus cerasinus* (LuCe), *Nocomis leptocephalus* (NoLe), *Luxilus albeolus* (LuAl), *Phoxinus oreas* (PhOr), *Lythurus ardens* (LyAr), and *Campostoma anomalum* (CaAn).

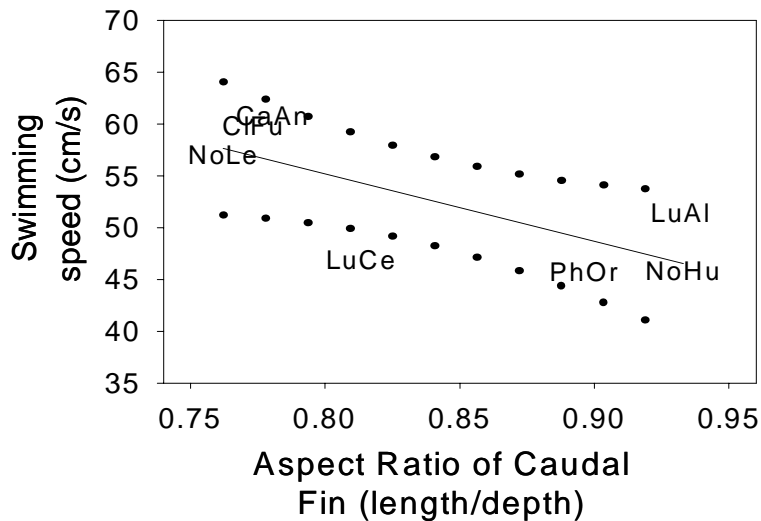

Figure 4.10. Plot of caudal fin aspect ratio versus critical swimming speed (cm/s) for seven minnows, including *Notropis hudsonius* (NoHu), *Clinostomus funduloides* (ClFu), *Luxilus cerasinus* (LuCe), *Nocomis leptocephalus* (NoLe), *Luxilus albeolus* (LuAl), *Phoxinus oreas* (PhOr), *Lythurus ardens* (LyAr), and *Campostoma anomalum* (CaAn).

Discussion

The swimming performance measured here was most representative of late spring to autumn conditions. Swimming performance was considerably higher than the maximum practice velocity used to start trials for all fishes. Most fish reached approximately 70% of their body length before fatigue, each cm of length representing 10 cm/s of velocity. Overall, the minnows studied here were capable of a maximum swimming performance of about six body lengths per second.

The large numbers of non-performers (38% of attempted runs) attest to the behavioral variation that besets swimming performance measures; some species exhibited more of a tendency to be non-performers than others. For example, 17 of 20 mountain red belly dace individuals completed trials while only 20 of 37 individuals of white shiner completed their trials. Perhaps the use of a pulsed electric field at the rear of the swim chamber as used in other studies (Jain et al., 1997) may have permitted increased sample sizes, but a longer acclimation period after capture may have been equally effective.

Fishes in my study were swum as soon as 24 hours after capture, but other studies with fewer non-performing fishes waited two weeks (after capture and cross-country transports) before beginning trials (Adams et al., 2000). Also, I transferred fishes in a net between holding tank and swim tunnel, but other studies have used containers of water (Adams et al., 2000). A longer adjustment period to the laboratory setting seems likely to have been the leading cause of non-performance based on my observations. Although, a longer acclimation period after transfer between tanks probably would not have increased performance rates, especially if a transfer tank was used instead of net to move individuals to the tunnel.

In the literature, there exists some debate over the use of acclimation periods in swimming tests. Most swimming performance research uses brief acclimation periods (Beamish, 1978), avoiding the long acclimation periods of early methods (Brett, 1964). The ramp critical swimming speed method reduced the time necessary for each swimming trial (Jain et al., 1997) while giving comparable results to previous methods. The ramping method used a practice swim set within the acclimation period. My method separated acclimation from the practice swim. In my study, fish that were non-performers usually failed to acclimate properly, i.e., they never swam during acclimation, just rested with their tail or whole body against the reach chamber screen, and most of these trials were halted before or just after starting the practice swims. Fish that were strong performers generally seemed to overcome the transfer among tanks rather rapidly, within 20-30 min. Therefore, combining acclimation with practice swimming would have possibly identified non-performers sooner, however, any beneficial effects of the acclimation period on performers might be lost. Certainly, an acclimation of 20-30 min seemed necessary for even performing fishes to recover from tank transfer. The effect of the 30 min rest period, after practice swims and before the swimming trials, was not examined.

Based on observations in this study and measurements of habitat use in other studies, it is recommended that a higher acclimation speed be used in future studies. The water velocity (10cm/s) used in acclimation was too low for larger fish to orient themselves properly (as well as too low for the beginning of practice swimming). Adams et al. (2000) found that Topeka shiners (similar size to fishes in this study) did not exceed sustained swimming ability (> 200 min) until they reached approximate speeds of 40 cm/s. Also, Aadland (1993) found that adult rheophilic

stream fishes occupied average water velocities greater than 15 cm/s. Therefore a water velocity of 20-30 cm/s should not have a negative effect on swim trials and would be more representative of field conditions for most species.

In this study, I attempted to link morphology, swimming performance, and habitat use, to provide a means for identifying habitat preference of warmwater stream fishes. I addressed two questions: do fishes living in fast water habitats have higher swimming ability than species in slow water habitats, and are there morphological traits related to swimming ability? Excluding pool species, fishes that inhabited fast water habitats have greater swimming ability than species in habitats with relatively slower flow. In addition, at least one morphological trait, the aspect ratio of the caudal fin, was identified as significantly related to swimming ability. This trait has been identified in the swimming performance literatures as having important consequences for thrust production, and drag reduction, of fishes (Videler, 1993). These relationships link form, function, and ecological consequence (resource use) for these fishes.

The swimming data collected in this study may also be useful in the context of designing instream structures, such as road crossings, and determining suitable habitat for species in instream flow studies. Also, habitat use as measured in field studies was at or near 60% of critical swimming ability for six rheophilic species (based on habitat use Vadas and Orth (1997, 2000)). If this relationship holds for other rheophilic fishes, it may serve as a tool for identifying habitat guild membership (see below).

For pool species, the spottail shiner and rosyside dace, had swimming ability well above speeds necessary for using pool habitat. For rosyside dace, observations of habitat use were taken from another stream (Facey and Grossman, 1992) and therefore differences in habitat availability among streams may have resulted in this discrepancy. Alternatively, for both species the need to escape predators might have explained relatively good swimming ability, but it would be more likely to influence burst speeds not prolonged swimming ability, especially since optimal accelerating and cruising designs are mutually exclusive (Webb, 1984). Instead, the relatively good prolonged swimming ability of these species may occur because of evolutionary history, i.e., they are stream minnows after all, or perhaps because of some contemporary life history requirement, such as the need to travel through high velocity patches when dispersing among pool

habitats, or swimming demands during storm spates. Rosyside dace distribution patterns can change seasonally suggesting the need to have flexible swimming performance requirements (Freeman and Grossman, 1993). Overall, swimming ability is more of a constraint on habitat use for species inhabiting flowing waters.

Swimming ability of a species is limited by inherent physiological and morphological design and as such becomes an excellent laboratory-measured indicator of maximum usable velocity. However, research has shown that maximum swimming ability of fishes exceeds their most efficient or optimal swimming speed (Parsons and Sylvester, 1992). Highest energy expenditures for 21 marine and freshwater fishes occurred at speeds of 0.5-1 length/s and 6-7 length/s or more (Belokopytkin and Shul'man, 1989). The most efficient, hence optimal, speeds were 2-3 length/s (Belokopytkin and Shul'man, 1989). The fishes of my study swam at 5-7 length/s, suggesting that water velocities of habitat observed in the field were close to optimal swimming speeds. Indeed, swimming speeds of five rheophilic species (*Luxilus albeolus*, *Luxilus cerasinus*, *Nocomis leptocephalus*, and *Campostoma anomalum* and *Phoxinus oreas*) calculated at either three or four body lengths/s were different from mid-point average water velocities by 6 cm/s or less. These species used water velocities near their optimal swimming speed which suggests that energetic considerations were important for microhabitat selection. Other fishes have been observed to select microhabitat based on energetic considerations, such as rainbow trout and rosyside dace (Facey and Grossman, 1992), and mottled sculpin (Petty and Grossman, 1996).

In addition to finding that swimming ability was related to microhabitat use for rheophilic species, results here suggest that some gross morphology traits have may have predictive ability for critical swimming speed. In this study, caudal fin shape was related to swimming ability. The form of the relationship when plotted might suggest a threshold value for the caudal fin aspect ratio that indicates “good” versus “excellent” swimmers. Species with high aspect ratios, having a more squared shaped fin, had poorer swimming ability. This was consistent with previous biomechanical studies of swimming in which fishes with more lunate tails have higher swimming ability (Webb, 1984; Sambilay, 1990; Videler, 1993). However, other researchers have used a more refined measure of caudal fin aspect ratio, height divided by the squared area of the fin, and

found it relates well to swimming ability (Sambily, 1990). Perhaps, this alternative measurement would provide a relationship that shows a more gradual transition of swimming ability with caudal fin shape.

Because of small sample sizes, relationships identified in this study need further testing, but if confirmed they may represent a means for predicting habitat preference or swimming ability from morphology of stream fishes. For example, morphology measurements could be made on specimens of a rare species. Those measurements when plotted on relationships like the ones identified in this study, can identify swimming ability (maximum usable water velocity). Relationships of swimming ability to habitat use, based on energetic considerations such as the 60% threshold found in this study, may then be used to identify a preferred habitat. In cases where empirical measurements of habitat use may not be possible, such as rare species, and when decisions must be made regarding instream flow changes, it may be possible to use this information to classify species into habitat guilds for instream flow analysis. Using flow models, and relationships of swimming ability, e.g., temperature and fish size, the availability of suitable habitat could be examined across seasons for different life stages of a species.

Morphology, swimming ability, and habitat use are directly linked through physiological constraints and the need for efficient expenditure of energy by fishes. Morphology promises to allow prediction of habitat preferences and these predictions may then be tested in the laboratory using swimming performance measures given that habitat use cannot exceed swimming ability. In general, this study found that minnows had the ability, on average, to swim at six body lengths per second, rheophilic species used an average habitat at 60% of their swimming ability, and morphology was significantly associated with swimming ability. Continued efforts to apply links of morphology, performance, and habitat use will allow managers to make improved decisions regarding the impacts of hydraulic changes to streams from human impacts and to mitigate against those impacts with management.

Summary

Chapter 1 Summary

Thirty morphology measurements were made on adults of 23 common fishes of the Roanoke River, Virginia, representing six families and 18 genera. There were 588 individuals measured.

Univariate analysis of all 30 morphology traits with ANOVA was not able to identify membership in habitat guilds for microhabitat (seven) or mesohabitat (three) guild frameworks.

After a stepwise variable selection procedure, 15 morphology traits were used to construct discriminant functions for predicting guild membership of species, using both a microhabitat and mesohabitat guild framework. Posterior misclassification rates using a holdout procedure were 17.2% of observations for microhabitat guilds and 30.9% of observations for mesohabitat guilds.

The selection of morphology traits to use in discriminant functions was not dependent on individual species used in the analysis. Overall misclassification was not related to the presence or absence of individual species in the function model.

Removing guilds with the highest misclassification rates (pool-covered, fast-generalist, and fast-riffle guilds) did not improve the overall ability of discriminant functions to separate remaining guilds. Overall misclassification rates decreased because removing these guilds prevented misclassification among guilds positioned very near to one another in multivariate space.

Overall sample size was not related to misclassification rates. There were no major differences in the average misclassification rates of both guilds and overall error when randomly removing individuals representing 10%, 25%, or 50% of the data set.

Sample size of species was related to misclassification rate of individuals of the species for some fishes (two of six species examined). Taking measurements on more than 20 fishes for each species was recommended.

Six species were examined for differences in classification rates among individuals within species based on their location of collection. Classification error rates were nearly the same for four species regardless of site, but two species did show differences. Species with wide distributions had less error than species that were not as widely distributed. Larger sample sizes (>20 individuals) taken at each site and sampling more sites for more patchily distributed fishes might have prevented these differences.

Transferability of the functions (models) was tested using two validation data sets, one for threatened and endangered fishes of Virginia and the other for common fishes of the Powell River. Predictions were correct for four of eight threatened species and for nine of 17 species from the Powell River. In validation tests, morphology was only partly successful (50%) at predicting habitat. Morphology correctly grouped species by shape, i.e., test fish were classified into guilds with fishes of the same genus or general shape, but did not identify habitat use because morphology and habitat were not closely associated through function, i.e., key tasks required to use habitat.

Chapter 2 Summary

The use of surrogate species, a phylogenetic approach, for identifying usable habitat of stream fishes was examined. Surrogate species were identified for 39 of 45 target species using phylogenetic trees from the literature. Five pairs were reciprocal matches of earlier pairs, e.g., sister taxa, and therefore dropped from further analysis so as not to be counted twice. Of 34 unique pairs, significant overlap of habitat use within pairs was present for both mesohabitat (pool, run, and riffle) and microhabitat (depth, water velocity, and substrate).

Overlapping use of mesohabitat types was evident for 29 of 34 target-surrogate pairs. For microhabitat, 11 of 16 pairs (69%) with data for all categories had complete overlap in usable habitat. When categories were considered independently to increase sample size, percentage of pairs with overlapping microhabitat was higher (>84%).

Comparing pairs of minnows at random was the least accurate in identifying usable habitat. Mesohabitat type overlapped in only 56% of comparisons. However, darters had very good overlap among pairs because as a group darters were more limited in their habitat use.

Examining microhabitat use of pairs of fishes using a single mesohabitat type provided the most accurate identification of habitat (>86% had overlap). However, comparisons of fishes using the same mesohabitats, but several of them, were not as good (as low as 60% within some categories). For fishes using several mesohabitat types, a surrogate from within the next highest taxonomic level, i.e., genus or subgenus, provided more accurate habitat information.

Overlap among darters of the same subgenus, *Percina* (*Percina*) and *Etheostoma* (*Nothonotus*), was 100%. Overlap in habitat among minnows of the same genus, *Luxilus* and *Notropis*, was only fair (70% or more). Divisions of habitat categories in this study may not have been sufficiently scaled to detect differences in habitat use of darters. Habitat thresholds were provided from the literature where the same divisions have been used to represent microhabitat guilds for fishes.

Of 10 rare or threatened species in this study, three had complete overlap in microhabitat with their nearest relative, one pair did not overlap in water velocity use, one pair did not overlap in two categories (mismatch), and five pairs had incomplete data (often lacking for surrogate species).

Surrogate species were not found for six target species. In four cases phylogenetic information was not found. A lack of habitat information was more of a bottleneck than a lack of phylogenetic information. Results from this study support the use of closely related surrogate species in situations where the target species uses several habitat types, but recommends the use of species from the same mesohabitat type when the target species uses a single mesohabitat type. Results of this study are limited to comparisons of fishes within the same physiographic province.

Chapter 3 summary

Relationships of fish morphology to Froude number were examined for four groups of fishes (benthic minnows, pelagic minnows, darters, and suckers). Significant linear regressions among Froude number and morphology traits were found for all groups.

Within darters, standardized caudal peduncle length decreased relative to overall body size as Froude number increased, i.e., more riffle-like habitat. The standardized distance from the pectoral to pelvic fin increased as Froude number increased.

For suckers, pectoral fin length increased as Froude number increased and specific energy increased as head length increased (distance between maxillary and pectoral fin). The mean size of substrate used by suckers decreased as head length increased.

The eye was position higher on benthic minnows inhabiting habitats of higher Froude number, while the caudal peduncle length also increased with increasing Froude number. This latter relationship was opposite to the same relationship for benthic darters. Finally, the distance from the end of the jaw decreased with decreasing Froude number. Benthic minnows in more pool like habitats had a smaller jaw length.

Pelagic minnows using habitat with lower Froude numbers also had greater distances between their pelvic and anal fins. Minnows in habitats of high Froude number had pelvic fins positioned further forward on their body, possibly to help stabilize the fish in more turbulent water flows. For suckers, standardized pectoral fin length increased as water flow went from pool to riffle like conditions. Because of limited sample size, this group could not be divided according to water column segregation (benthic suckers vs. open-water suckers).

Morphology was related to habitat use as described by Froude number. Froude number should be considered as a better descriptor of habitat conditions and more widely applied in habitat analysis. Morphology-habitat relationships were not transferable across ecomorphological guilds,

suggesting that further analysis should be considered within fish families, with consideration for water column segregation.

Chapter 4 summary

Swimming performance for eight minnows was measured. Mean critical swimming speeds were determined as follows: *Campostoma anomalum* (n=1), 60.7 cm/s and 10.6 bls, *Clinostomus funduloides* (n=11), 59.8 cm/s and 9.4 bls; *Luxilus albeolus* (n=20), 51.4 cm/s and 9.6 bls; *Luxilus cerasinus* (n=19), 46.9 cm/s and 9.1 bls; *Lythrurus ardens* (n=13), 50.2 cm/s and 7.4 bls; *Nocomis leptocephalus* (n=2), 57.0 cm/s and 11.6 bls; *Notropis hudsonius* (n=2), 45.8 cm/s and 7.3 bls; and *Phoxinus oreas* (n=17), 45.7 cm/s and 6.2 bls.

There were no significant interactions among species, fish length, and water temperature, therefore to test for differences among species a general linear model with only main effects was used. Effects of fish length and temperature were significant (fish length, p value < 0.0004, and water temperature, p-value < 0.0008). Differences in ability among species was nearly significant (p value = 0.07). Swimming ability increased with increases in fish length and temperature.

Analyses of pairwise differences among mean ability, adjusted for temperature and fish length, found significant differences between *Clinostomus funduloides* and *Luxilus cerasinus* (p-value = 0.04). *Clinostomus funduloides* swam faster than similarly sized *L. cerasinus*.

Critical swimming speeds measured in this study exceeded both the mid-point mean and maximum average habitat used. For rheophilic species, habitat use was approximately 60% of swimming performance. This rate of speed coincided with theoretical, optimal swimming speeds for efficient energy expenditure.

One significant (p-value = 0.05) and two nearly significant regressions (p-value < 0.08) were identified for swimming performance against habitat use and morphology traits. Maximum water velocities occupied in streams were related with absolute (unadjusted for body size) critical

swimming speed such that fishes capable of faster swimming had been recorded to use higher water velocities. Relative swimming ability (in body lengths/s) was related to the distance between pectoral and pelvic fins such that fishes with shorter distances between fins were generally faster swimmers per body length. Caudal fin aspect ratio was related to critical swimming speed (cm/s), unadjusted for fish length, such that fishes with caudal fins shaped more like a square demonstrated poorer swimming ability.

Morphology, swimming ability, and habitat use were directly linked through physiological constraints and the need for efficient energy expenditure by fishes. The use of ecomorphological guilds (based within families or lower taxonomic levels, considering water column use) and functional anatomy can be useful as a tool for predicting habitat preference of stream fishes, especially for rare, endangered, or unstudied species. Ecomorphological approaches further allow predictions to be tested using laboratory measures, such as swimming performance.

Conclusions and Management Implications

The central theme of my research has been fish ecomorphology. The goal of my research was to improve instream flow studies by creating more knowledge about fish habitat for managers so they may employ community level approaches to instream flow analysis. The objective of this work has been establishing links among fish morphology and their observed habitat use.

I explored four hierarchical approaches to using morphology to predict usable habitat of warmwater stream fishes. First, I tested the use of morphology to predict membership in habitat guilds, an indirect approach to identifying habitat use (Chapter 1). Results indicate that the guild frameworks must be applied within fish families and variation in shape due to lifestyles, e.g., pelagic vs. benthic species, must be considered if morphology is to predict guild membership. For managers, the utility of habitat guilds is that they limit the number of elements within an instream flow analysis. Applying the guild framework within families for morphology analysis will only increase the number of elements temporarily. Once habitat use has been identified, members of the same guild across families may be aggregated into one set for analyses. Sample size limitations prevented the study of guilds within families in this study, and I hope to conduct further research examining the use of morphology to distinguish guilds within families, particularly for darters and minnows. The diversity of darters and minnows suggest that many species would have overlap in habitat use and that habitat guilds would be particularly useful for flow analysis with these groups, especially since there is a lack of habitat use information for many of these species.

The lack of usable habitat information for many species impedes community level assessments within many instream flow studies. Particularly, identifying habitat use for rare, threatened or endangered fishes may be difficult as habitat may already be degraded, sample sizes difficult to obtain, or sampling impacts may pose an unacceptable risk to populations. The second method of predicting habitat preferences was a phylogenetic approach using closely related surrogate species to identify usable habitat of target species (Chapter 2). Surrogate species were identified as the most closely related species to a target fish on the most recent phylogenetic trees. Observed habitat use reported in the literature was compared directly for overlap between species. In summary, habitat overlap was highest among pairs of fishes that both used the same, single

mesohabitat. When target species used more than one habitat, surrogate species from within the next highest taxonomic level, e.g., genus or subgenus, provided the most accurate habitat information. Using the most closely related taxa to a target species did not provide the most accurate habitat information.

The imprecise nature of available habitat criteria (categories of use) was not amenable to statistical tests of transferability, and if they were they probably would not pass. However, this method is being targeted at situations where no or little information exists and therefore some data is better than no data. In addition, impact of the uncertainty can be quantified on instream flow decisions by modeling different scenarios of the range and suitability of use, but at least an idea of the species requirements with a firm theoretical foundation for the link between organism and habitat has been established. Indeed, consideration of the range of habitat use may be more biologically significant than typical microhabitat data developed for instream flow studies. At a minimum, this approach may be used to place species into habitat guilds for flow studies.

In the end, limited habitat information was the bottleneck for applying a phylogenetic approach of surrogate species. However, phylogenetic trees may be used as road maps for managers wishing to prioritize the need for habitat information. Gaps in available habitat information may be identified based on phylogenetic relationships rather than on a species level. Priority for resources should be given to entire phylogenetic groups where no thorough studies of at least one species has been conducted rather than individual species in well studied groups. This minimal amount of information would greatly improve the collective understanding of habitat needs for fish communities and provide valuable information for flow management.

In the third chapter, the relationship between Froude number, a simple hydraulic variable and fish morphology was examined. This represented a direct approach to predicting habitat use at the level of the individual species. Fish morphology was related to hydraulic variables calculated from reported habitat use, although sample sizes were small and results should be considered tentative. Little work has been done to examine hydraulic variables as indicators of habitat criteria, despite their ease of calculation in flow modeling software and their ability to integrate simple habitat variables which are known to be non-independent. Also, complex hydraulic variables are often dimensionless and therefore better descriptors of hydraulic condition;

they facilitate physical comparisons of habitat among streams. Establishing connections among easily modeled hydraulic variables and simple morphology metrics will integrate theory of stream hydrology and physical conditions with fish habitat preferences, creating a stronger and more flexible foundation of knowledge for management of water resources.

Finally, I used the fundamental ecomorphological approach to predicting habitat use for fishes that is an approach that establishes a connection among morphology and important life tasks such as swimming and then examines how variation in task performance constrains habitat use. From these relationships, morphology can then be used to predict habitat use. In this study, swimming was related to habitat use, the reported maximum velocities were approximately 60% of measured swimming ability for six rheophilic minnow species, two limnophilic species were exceptions. A plot of distance between pectoral and pelvic fins against swimming performance suggested a linear relationship between the variables. A plot of caudal fin aspect ratio against swimming performance suggested a threshold effect with fishes that have aspect ratios above 0.84 swimming slower than fishes with ratios below that value. These analyses need more work and larger sample sizes to fully confirm and describe the relationships, but by understanding the relationships of morphology to swimming performance and in turn to habitat use, morphology may be used to predict habitat preference. Swimming performance can then be measured in the lab as a validation of the prediction or limited field measurements may be used to test against the prediction.

To date the use of morphology as a predictor of habitat use via swimming performance has not been widely explored for nongame fishes. The strength of the ecomorphological approach is the extensive body of hydrodynamic theory that can provide strong explains of how morphology influences swimming ability. It appears for rheophilic minnows that this approach may be a viable method for predicting habitat use, but a different relationship will be needed for limnophilic minnows because swimming ability far exceeds the average and maximum velocities they occupy. Limnophilic minnows appear to have a morphology that gives them good swimming performance merely because they are minnows, although other ecological reasons may exist for such high performance such as the need to overcome higher flows in order to disperse. Also, this method may not work well for benthic species because these fishes have alternative ways of

dealing with flow (such as behavior, using shelters, using gradients) and the theory of how their morphology aids them in habitat use is not well developed. In summary, managers wishing to identify habitat use of rheophilic fish species, particularly upper water column species, should consider an ecomorphological approach. I will continue development of these relationships because the ecomorphological approach provides a widely transferable product across species, rather than the slow accumulation of swimming measurements, species by species.

This dissertation has developed or refined four approaches that managers may use to improve the identification of habitat preferences for fishes. Techniques examined here are employable at different scales, habitat groups within communities, pairs of close relatives, and individuals. Each approach has value depending on the management question, but together these four approaches offer flexibility for managers in water resource management. This research demonstrated links between morphology, swimming and observed habitat of fishes that will improve river and stream management by allowing managers to apply ecomorphological approaches to identifying fish habitat requirements.

Literature Cited

- Aadland, L. P. 1993. Stream habitat types: their fish assemblages and relationship to flow. *N. Am. J. Fish. Manag.* 13:790-806.
- Adams, S. R., and G. R. Parsons. 1996. Swimming performance of the smallmouth buffalo, *Ictiobus bubbalus*. Final Report to U.S. Army Corps of Engineers, Waterways Experiment Station, Vicksburg, MS.
- , and -----. 1998. Laboratory-based measurements of swimming performance and related metabolic rates of field-sampled smallmouth buffalo (*Ictiobus bubbalus*): A study of seasonal changes. *Physiol. Zool.* 71(4):350-358.
- , J. J. Hoover, and K. J. Killgore. 2000. Swimming performance of the Topeka shiner (*Notropis topeka*) an endangered midwestern minnow. *Am. Midl. Nat.* 144:178-186.
- Aleev, Yu. G. 1969. Function and gross morphology in fish. V. A. Vodyanitskii (ed), Israel Program for Scientific Translations, Jerusalem.
- Allan, J. D. 1995. Stream ecology: structure and function of running waters. Chapman and Hall, New York.
- Angermeier, P. L. 1987. Spatial temporal variation in habitat selection by fishes in a small Illinois streams, p. 52-60. *In* Community and evolutionary ecology of North American stream fishes. W. J. Matthews, and D. C. Heins (eds.). Univ. Oklahoma Press, Norman.
- Bain, M. B., and J. M. Botz. 1989. Regulated streamflow and warmwater stream fish: A general hypothesis and research agenda. Alabama Coop. Fishery Research Unit, Auburn. Biological Report 89(18).
- , J. T. Finn, and H. E. Booke. 1988. Streamflow regulation and fish community structure. *Ecology* 69(2):382-392.
- Balon, E. K. 1975. Reproductive guilds of fishes: a proposal and definition. *J. Fish. Res. Board Can.* 32:821-864.
- Bandyopadhyay, P. R., J. M. Castano, J. Q. Rice, R. B. Phillips, W. H. Nedderman, and W. K. Macy. 1997. Low-speed maneuvering and hydrodynamics of fish and small underwater vehicles. *J. Fluids Eng.* 119:136-144.

- Barlow, K. E., G. Jones, and E. M. Barratt. 1997. Can skull morphology be used to predict ecological relationships between bat species? A test using two cryptic species of pipistrelle. *Proc. R. Soc. Lond.* 264B:1695-1700.
- Beamish, F. W. H. 1975. Apparent specific dynamic action of largemouth bass, *Micropterus salmoides*. *J. Fish. Res. Board Can.* 31:1763-1769.
- 1978. Swimming capacity, p.101-187. *In Fish Physiology*. Vol. 7. W. S. Hoar, and D. J. Randall (eds.). Academic Press, New York.
- Belokopytkin, YuS., and G. E. Shul'man. 1989. On energy cost of fish swimming. *J. Gen. Biol.* 50(6):836-840.
- Blažka, P., M. Volf, and M. Cepela. 1960. A new type of respirometer of the determination of the metabolism of fish in an active state. *Physiol. Bohemoslov* 9: 553-558.
- Bovee, K. D. 1986. Development and evaluation of habitat suitability criteria for use in the instream flow incremental methodology: instream flow information paper 21. U.S. Fish and Wildlife Service, Biological Report 86(7).
- 1995. A comprehensive overview of the instream flow incremental methodology. National Biological Series, Fort Collins, CO.
- Bouckaert, F. W., and J. Davis. 1998. Microflow regimes and the distribution of macroinvertebrates around stream boulders. *Fresh. Biol.* 40(1):77-86.
- Bowie, R. C. K., D. S. Jacobs, and P. J. Taylor. 1999. Resource use by two morphologically similar insectivorous bats. *S. Afr. J. Zool.* 34(1):27-33.
- Boyd, G. L., and G. R. Parsons. 1998. Swimming performance and behavior of golden shiner, *Notemigonus crysoleucas*, while schooling. *Copeia* 1998(2):467-471.
- Braaten, P. J., and C. R. Berry, Jr. 1997. Fish associations with four habitat types in a South Dakota prairie stream. *J. Freshwat. Ecol.* 12(3):477-489.
- Brett, J. R. 1964. The respiratory metabolism and swimming performance of young sockeye salmon. *J. Fish. Res. Board Can.* 21:1183-1226.
- Brigham, R. M., R. L. Francis, and S. Hamdorf. 1997. Microhabitat use by two species of *Nyctophilus* bats: a test of ecomorphology theory. *Australian. J. Zool.* 45:553-560.
- Caro, T. M., and G. O'Doherty. 1999. On the use of surrogate species in conservation biology. *Conservation Biology.* 13(4):805-814.

- Castleberry, D. T., J. J. Cech, Jr., D. C. Erman, D. Hankin, M. Healey, G. M. Kondolf, M. Mangel, M. Mohr, and P. B. Moyle. Uncertainty and instream flow standards. *Fisheries*. 21(8):20-21.
- Chocat, B., G. Hubert, and S. Aguilar. 1998. Urban development and hydrology. *Tech. Sci. Methodes Genie Urbain-Genie Rural* 1998(6):23-29.
- Clark, M. E., and K. A. Rose. An individual-based modeling analysis of management strategies for enhancing brook trout populations in southern Appalachian streams. *N. Am. J. Fish. Manage.* 17(1):54-76.
- Collier, M., R. H. Webb, and J. C. Schmidt. 1996. Dams and Rivers: primer on the downstream effects of dams. U. S. Geological Survey Circular 1126, Denver, CO.
- Crome, F. H. J., and G. C. Richards. 1988. Bats and gaps: microchiropteran community structure in a Queensland rain forest. *Ecology* 69(6):1960-1969.
- Crowder, D. W., and P. Diplas. 2000. Evaluating spatially explicit metrics of stream energy gradients using hydrodynamic model simulations. *Can. J. Fish. Aquat. Sci.* 57:1497-1507.
- Danehy, R. J., N. H. Ringler, S. V. Stehman, and J. M. Hassett. Variability of fish densities in a small catchment. *Ecol. Freshwat. Fish.* 7(1):36-48.
- Denny, M. W. 1994. Roles of hydrodynamics in the study of life on wave-swept shores, p. 169-204. *In Ecological morphology* P. C. Wainwright, and S. M Reilly (eds.). Univ. of Chicago Press, Chicago.
- Douglas, M. E., and W. J. Matthews. 1992. Does morphology predict ecology? Hypothesis testing within a freshwater stream fish assemblage. *Oikos* 65(2):213-224.
- Dowling, T. E., W. R. Hoeh, G. R. Smith, and W. M. Brown. 1992. Evolutionary relationships of shiners in the genus *Luxilus* (Cyprinidae) as determined by analysis of mitochondrial DNA. *Copeia* 1992(2):306-322.
- Duthie, G. G. 1987. Observations of poor swimming performance among hatchery-reared rainbow trout, *Salmo gairdneri*. *Environ. Biol. Fishes* 18(4):309-311.
- Easterling, D. R., G. A. Meehl, C. Parmesan, S. A. Changnon, T. R. Karl, and L. O. Mearns. 2000. Atmospheric science: climate extremes, observations, modeling and impacts. *Science* 2000(5487):2068-2074.
- Etnier, D. A., and W. C. Starnes. 1993. The fishes of Tennessee. Univ. of Tenn. Press, Knoxville.

- Facey, D. E., and G. D. Grossman. 1990. The metabolic cost of maintaining position for four north American stream fishes: Effects of season and velocity. *Physiol. Zool.* 63(4):757-776.
- , and ----- . 1992. The relationship between water velocity, energetic costs, and microhabitat use in four North American stream fishes. *Hydrobiologia.* 239:1-6.
- Fausch, K. D. 1988. Tests of competition between native and introduced salmonids in streams. What have we learned? *Can. J. Fish. Aquat. Sci.* 45(12):2238-2246.
- Fauth, J. E., J. Bernadro, M. Camara, W.J. Resetarits Jr., J. Van Buskrik, and S. A. McCollum. 1996. Simplifying the jargon of community ecology: a conceptual approach. *Am. Nat.* 147(2):282-286.
- Felley, J. D. 1984. Multivariate identification of morphological-environmental relationships within the cyprinidae (Pisces). *Copeia* 1984(2):442-455.
- Fischer, S. A., L. W. Hall Jr., and W. D. Killen Jr. 1992. Distribution of the endangered glassy darter, *Etheostoma vitreum*, in Maryland coastal plain streams. *Va. J. Sci.* 43(1A):47-52.
- Fisher, W. L. 1990. Life history and ecology of the orangefin darter *Etheostoma bellum* (Pisces: Percidae). *Am. Mid. Nat.* 123:268-281.
- Freeman, M. C., and G. D. Grossman. 1993. Effects of habitat availability on dispersion of a stream cyprinid. *Environ. Biol. Fish.* 37(2):121-130.
- , Z. H. Bowen, and J. H. Crance. 1997. Transferability of habitat suitability criteria for fishes in warmwater streams. *N. Am. J. Fish. Manag.* 17:20-31.
- , -----, and K. D. Bovee. 1999. Transferability of habitat suitability criteria: response to comment. *N. Am. J. Fish. Manag.* 19:626-628.
- Gatz, A. J., Jr. 1979a. Ecological morphology of freshwater stream fishes. *Tul. Stud. Zool. Bot.* 21(2):91-124.
- . 1979b. Community organization in fishes as indicated by morphological features. *Ecology* 60(4):7111-718.
- Gerstner, C. L. 1999. Maneuverability of four species of coral-reef fish that differ in body and pectoral-fin morphology. *Can. J. Zool.* 77:1102-1110.
- Gilbert, C. R. 1969. Systematics and distribution of the American cyprinid fishes *Notropis ariommus* and *Notropis telescopus*. *Copeia.* 1969:474-492.

- Glozier, N. E., J. M. Culp, and G. J. Scrimgeour. 1997. Transferability of habitat suitability curves for a benthic minnow, *Rhinichthys cataractae*. *J. Freshwater Ecol.* 12(3):379-393.
- Gold, J. R., C. J. Ragland, and J. B. Woolley. 1992. Evolution of genome size in North American fishes, p. 534-552. *In* Systematics, historical ecology, and North American freshwater fishes. R. L. Mayden (ed.). Stanford Univ. Press, Stanford.
- Gordon, N. D., T. A. McMahon, and B. L. Finlayson. 1992. *Stream Hydrology*. John Wiley and Sons, New York.
- Grady, J. M., and W. H. LeGrande. 1992. Phylogenetic relationships, modes of speciation, and historical biogeography of the madtom catfishes, genus *Noturus* Rafinesque (Siluriformes: Ictaluridae), p. 747-777. *In* Systematics, historical ecology, and North American freshwater fishes. R. L. Mayden (ed.). Stanford Univ. Press, Stanford.
- Groshens, T. P., and D. J. Orth. 1993. Transferability of habitat suitability criteria for smallmouth bass, *Micropterus dolomieu*. *Rivers* 4(3): 194-212.
- Hall, R. I., P. R. Leavitt, R. Quinlan, A. S. Dixit, and J. P. Smol. 1999. Effects of agriculture, urbanization, and climate on water quality in the northern Great Plains. *Limnol. Oceanogr.* 44(3, Supp. 2):739-756.
- Hammer, C. 1995. Fatigue and exercise tests with fish. *Comp. Biochem. Physiol.* 112A(1):1-20.
- Harder, L. D. 1985. Morphology as a predictor of flower choice by bumble bees. *Ecology* 66(1):198-210.
- Harrell, R. D., and D. G. Cloutman. 1978. Distribution and life history of the sandbar shiner, *Notropis scepticus* (Pisces: Cyprinidae). *Copeia* 1978(3):443-447.
- Harrison, M. K., and B. J. Crespi. 1999. A phylogenetic test of ecomorphological adaptations in *Cancer* crabs. *Evolution.* 53(3):961-965.
- Hartwell, S. I., and R. G. Otto. 1978. Swimming performance of juvenile menhaden (*Brevoortia tyrannus*). *Trans. Am. Fish. Soc.* 107(6):793-798.
- Hawkins, D. K., and T. P. Quinn. 1996. Critical swimming velocity and associated morphology of juvenile coastal cutthroat trout (*Oncorhynchus clarki clarki*), steelhead trout (*Oncorhynchus mykiss*), and their hybrids. *Can. J. Fish. and Aquat. Sci.* 53:1487-1496.
- Jain, K. E., J. C. Hamilton, and A. P. Farrel. 1997. Use of a ramp velocity test to measure critical swimming speed in rainbow trout (*Oncorhynchus mykiss*). *Comp. Biochem. Physiol.* 117A(4):441-444.

- Jenkins, R. E., and N. M. Burkhead. 1975. Distribution and aspects of life history and morphology of the cyprinid fish *Notropis semperasper* endemic to the upper James River drainage, Virginia. *Chesapeake Sci.* 16(3):178-191
- , and -----. 1984. Description, biology and distribution of the spotfin chub, *Hybopsis monacha*, a threatened cyprinid fish of the Tennessee River drainage. *Bull. Alabama Mus. Nat. Hist.* 8:1-30.
- , and -----. 1994. *Freshwater fishes of Virginia.* Am. Fish. Soc., Bethesda, MD.
- Johnsson, J. I. 1993. Big and brave: size selection affects foraging under risk of predation in juvenile rainbow trout, *Oncorhynchus mykiss*. *Anim. Behav.* 45(6):1219-1225.
- Johnston, C. E. and L. M. Page. 1992. The evolution of complex reproductive strategies in North American minnows (cyprinidae), p. 600-621. *In* Systematics, historical ecology, and North American freshwater fishes. R. L. Mayden (ed.). Stanford Univ. Press, Stanford.
- Jones, D. R. 1982. Anaerobic exercise in teleost fish. *Can. J. Zool.* 60:1131-1134.
- Karim, K., M. E. Gubbels, and I. C. Goulter. 1995. Review of determination of instream flow requirements with special application to Australia. *Water Res. Bull.* 31(6):1063-1077.
- Kessler, R., K., and J. H. Thorp. 1993. Microhabitat segregation of the threatened spotted darter (*Etheostoma maculatum*) and closely related orangefin darter (*E. bellum*). *Can. J. Fish. Aquat. Sci.* 50:1084-1091.
- , K., A. F. Casper, and G. K. Weddle. 1995. Temporal variation in microhabitat use and spatial relations in the benthic fish community of a stream. *Am. Mid. Nat.* 134:361-370.
- Kolok, A. S. 1991. Photoperiod alters the critical swimming speed of juvenile largemouth bass, *Micropterus salmoides*, acclimated to cold water. *Copeia* 1991(4):1085-1090.
- Lachner, E. A., and R. E. Jenkins. 1971. Systematics, distribution and evolution of the chub genus *Nocomis* Girard of the eastern United States with a description of a new species. *Smithsonian Contr. Zool.* 85(97).
- Lamouroux, N., J-M. Olivier, H. Persat, M. Pouilly, Y. Souchon, B. Statzner. Predicting community characteristics from habitat conditions: fluvial fish and hydraulics. *Freshwat. Biol.* 42(2):275-299.

- Layzer, J. B., and L. M. Madison. 1995. Microhabitat use by freshwater mussels and recommendations for determining their instream flow needs. *Reg. Rivers: Res. Manag.* 10:329-345.
- Leisler, B., and H. Winkler. 1985. Ecomorphology, p. 155-186. *In Current Ornithology* R. F. Johnston. Vol. 2. Plenum Press, New York..
- Leonard, P. M., and D. J. Orth. 1988. Use of habitat guilds of fishes to determine instream flow requirements. *N. Am. J. Fish. Manag.* 8:399-409.
- Lobb, M. D., III, and D. J. Orth. 1988. Microhabitat use by the bigmouth chub *Nocomis platyrhynchus* in the New River, West Virginia. *Am. Midl. Nat.*120(1):32-40.
- , and -----. 1991. Habitat use by an assemblage of fish in a large warmwater stream. *Trans. Am. Fish. Soc.* 120:65-78.
- Matheney, M. P., IV, and C. F. Rabeni. 1995. Patterns of movement and habitat use by northern hog suckers in an Ozark stream. *Trans. Am. Fish. Soc.* 124:886-897.
- Matthews, W. J. 1985. Critical current speeds and microhabitat of the benthic fishes *Percina roanoka* and *Etheostoma flabellare*. *Environ. Biol. Fishes* 12(4):303-308.
- , 1998. Patterns in freshwater fish ecology. Kluwer Academic Publishers, Hingham, Massachusetts.
- , and L. G. Hill. 1980. Habitat partitioning in the fish community of a southwestern river. *The Southwestern Nat.* 25(1):51-66
- , J. R. Bek, and E. Surat. 1982. Comparative ecology of the darters *Etheostoma podostemone*, *E. flabellare* and *Percina roanoka* in the upper Roanoke River drainage, Virginia. *Copeia* 1982(4):805-814.
- Mayden, R. L. 1989. Phylogenetic studies of North American minnows with emphasis on the genus *Cyprinella* (Teleostei: Cypriniformes). *Univ. Kansas Mus. Nat. Hist. Misc. Publ.* 80. Univ. Kansas, Lawrence.
- McNeely, D. L. 1987. Niche relations within an Ozark stream cyprinid assemblage. *Environ. Biol. Fishes* 18(3):195-208.
- Mesa, M. G., and T. M. Olson. 1993. Prolonged swimming performance of northern squawfish. *Trans. Am. Fish. Soc.* 122:1104-1110.

- Milhous, R. T., M. A. Updike, and D. M. Schneider. 1989. Physical habitat simulation system (PHABSIM) reference manual, version II. Instream Flow Inf. Pap. No. 26, U.S. Fish Wildl. Serv. Biol. Rep. 89(6).
- Mittelbach, G. G. 1984. Predation and resource partitioning in two sunfishes (Centrarchidae). *Ecology*. 65:449-513.
- Moermond, T. C. 1979. Habitat constraints on the behavior, morphology, and community structure of *Anolis* lizards. *Ibid.* 60(1):152-164.
- , 1986. A mechanistic approach to the structure of animal communities: *Anolis* lizards and birds. *Amer. Zool.* 26:23-37.
- Moody, R. C. 1989. Habitat use, availability, and preference for johnny darter, white sucker, norther hog sucker, common shiner, and creek chub in streams in central Wisconsin. M.S. Thesis, Univ. Wisconsin, Stevens Point, Wisconsin.
- Moran, N. A. 1986. Morphological adaptation to host plants in Uroleucon (Homoptera: Aphididae). *Evolution* 40(5):1044-1050.
- Moss, R. E. 1983. Microhabitat selection in Neosho River riffles. Ph.D. dissertation, Univ. Kansas, Lawrence, Kansas.
- Motta, P. J., and K. M. Kotrschal. 1992. Correlative, experimental, and comparative evolutionary approaches in ecomorphology. *Netherlands J. Zool.* 42(2-3):400-415.
- , K. B. Clifton, P. Hernandez, and B. T. Eggold. 1995a. Ecomorphological correlates in ten species of subtropical seagrass fishes: diet and microhabitat utilization. *Environ. Biol. Fishes.* 44:37-60.
- , S. F. Norton, and J. J. Luczkovich. 1995b. Perspectives on the ecomorphology of bony fishes. *Environ. Biol. Fishes.* 44:11-20.
- Moyle, P. B., and D. M. Baltz. 1985. Microhabitat use by an assemblage of California stream fishes: developing criteria for instream flow determinations. *Trans. Am. Fish. Soc.* 114:695-704.
- Nakano, S., S. Kitano, K. Nakai, K. D. Fausch. 1998. Competitive interactions for foraging microhabitat among introduced brook charr, *Salvelinus fontinalis*, and native bull charr, *S. confluentus*, and westslope cutthroat trout, *Oncorhynchus clarki lewisi*, in a Montana stream. *Environ. Biol. Fish.* 52(1-3): 345-355.

- Nelson, J. A. 1989. Critical swimming speeds of yellow perch *Perca flavescens*: comparison of populations from a naturally acidic lake and a circumneutral lake in acid and neutral water. *J. Exp. Biology* 145:239-254.
- Nelson, P. A., W. G. Franzin, and N. C. Kenkel. 1999. Organization of sympatric catostomids (Osteichthyes: Catostomidae) in a riverine system: habitat use and historical ecology. *Am. Fish. Soc. Annual Meeting*, Bethesda, MD.
- Newcomb, T. J., S. A. Perry, and W. B. Perry. 1995. Comparison of habitat suitability criteria for smallmouth bass (*Micropterus dolomieu*) from three West Virginia rivers. *Rivers* 5(3):170-183.
- Nilsson, P. A., and C. Broenmark. 2000. Prey vulnerability to a gape-size limited predator: behavioural and morphological impacts on northern pike piscivory. *Oikos* 88(3):539-546.
- Norton, S. F. 1995. A functional approach to ecomorphological patterns of feeding in cottid fishes. *Environ. Biol. Fishes* 44:61-78.
- Novinger, D. C., and T. G. Coon. 2000. Behavior and physiology of the redbside dace, *Clinostomus elongatus*, a threatened species in Michigan. *Ibid.* 57:315-326.
- Outtern, L. M. 1958. Studies of the life history of the cyprinid fishes *Notropis galacturus* and *rubricroceus*. *J. Elisha Mitchell Soc.* 1958:122-134.
- P. G. & E. (Pacific Gas and Electric Company). 1994. Evaluation of factors causing variability in habitat suitability criteria for sierra Nevada trout. Report # 009.4-94.5.
- Page, L. M. 1975. The life history of the stripetail darter, *Etheostoma kennicotti*, in Big Creek, Illinois. *Illinois Nat. Hist. Survey Biol. Notes* 93:1-15.
- , 1981. The genera and subgenera of darters (Percidae, Etheostomatini). *Occ. Pap. Mus. Nat. Hist. Univ. Kansas* 90:1-69.
- , and B. M. Burr. 1991. A field guide to freshwater fishes. Houghton Mifflin Co., Boston.
- , and D. L. Swofford. 1984. Morphological correlates of ecological specialization in darters. *Environ. Biol. Fish.* 11(2):139-159.
- Parsons, G. R. 1990. Metabolism and swimming efficiency of the bonnethead shark *Sphyrna tiburo*. *Marine Biol.* 104:363-367.

- , and J. L. Sylvester, Jr. 1992. Swimming efficiency of the white crappie, *Pomoxis annularis*. *Copeia* 1992 (4):1033-1038.
- Peake, S., R. S. McKinley, and D. A. Scruton. 1997. Swimming performance of various freshwater Newfoundland salmonids relative to habitat selection and fishway design. *J. Fish Biol.* 51(4):710-723.
- Petts, G. E. 1989. Perspectives for ecological management of regulated rivers, p. 3-24 *In* Alternatives in regulated river management. J. A. Gore and G. E. Petts (eds.). CRC Press, Boca Raton, FL.
- Petty, J. T., and G. D. Grossman. 1996. Patch selection by mottled sculpin (Pisces: Cottidae) a southern Appalachian stream. *Fresh. Biol.* 35(2): 261-276.
- Pizzuto, J. E., W. C. Hession, and M. McBride. 2000. Comparing gravel-bed rivers in paired urban and rural catchments of southeastern Pennsylvania. *Geology* 28(1): 79-82.
- Poff, N. L. 1997. Landscape filters and species traits: Towards mechanistic understanding and prediction in stream ecology. *J. N. Am. Benthol. Soc.* 16(2):391-409.
- Polivka, K. M. 1999. The microhabitat distribution of the Arkansas River shiner, *Notropis girardi*: a habitat-mosaic approach. *Environ. Biol. Fishes* 55:265-278.
- Porterfield, J. C., L. M. Page and T. J. Near. 1999. Phylogenetic relationships among fantail darters (Percidae: *Etheostoma*: *Catonotus*): total evidence analysis of morphological and molecular data. *Copeia* 1999(3):551-564.
- Raney, E.C., and E. A. Lachner. 1946. *Thoburnia hamiltoni*, a new sucker from the upper Roanoke River system in Virginia. *Ibid.* 1946(4):218-226.
- Rerrpel, L. L., J. S. Richardson, and M. C. Healey. 1999. Flow refugia for benthic macroinvertebrates during flooding of a large river. *J. N. Am. Benthol. Soc.* 18(1):34-48.
- Ricklefs, R. E., and J. Travis. 1980. A morphological approach to the study of avian community organization. *The Auk.* 97:321-338.
- Rinne, J. N. 1992. Physical habitat utilization of fish in a Sonoran desert stream, Arizona, southwestern United States. *Ecol. Freshwat. Fishes* 1:35-41.
- Robison, H. W., and T. M. Buchanan. 1988. *Fishes of Arkansas*. Univ. Arkansas Press, Fayetteville, Arkansas.

- Rose, K. A., E. S. Rutherford, D. S. McDermot, J. L. Forney, E. L. Mills. 1999. Individual-based model of yellow perch and walleye populations in Oneida Lake. *Ecol. Monogr.* 69(2):127-154.
- Sagnes, P., P. Gaudin, and B. Statzner. 1997. Shifts in morphometrics and their relation to hydrodynamic potential and habitat use during grayling ontogenesis. *J. Fish Biol.* 50:846-858.
- Sambily, V. C., Jr. 1990. Interrelationships between swimming speed, caudal fin aspect ratio and body length of fishes. *Fishbyte* 8(3):16-20.
- Saunders, M. B., and R. M. R. Barclay. 1992. Ecomorphology of insectivorous bats: a test of predictions using two morphologically similar species. *Ecology.* 73(4):1335-1345.
- Schaefer, J. F., W. I. Lutterschmidt, and L. G. Hill. 1999. Physiological performance and stream microhabitat use by the centrarchids *Lepomis megalotis* and *Lepomis macrochirus*. *Environ. Biol. Fishes* 54:303-312.
- Schoener, T. W. 1986. Mechanistic approaches to community ecology: a new reductionism. *Amer. Zool.* 26:81-106.
- Shoup, D. E., and L. G. Hill. 1997. Ecomorphological diet predictions: an assessment using inland silverside (*Menidia beryllina*) and longear sunfish (*Lepomis megalotis*). *Hydrobiologia* 350:87-98.
- Sibbing, F. A., L. A. J. Nagelkerke, and J. W. M. Osse. 1994. Ecomorphology as a tool in fisheries: Identification and ecotyping of Lake Tana barbs (*Barbus intermedius* complex), Ethiopia. *Neth. J. Agric. Sci.* 42(1):77-85.
- Simonson, T. D., and R. J. Neves. 1992. Habitat suitability and reproductive traits of the orangefin madtom *Noturus gilberti* (Pisces: Ictaluridae). *Am. Midl. Nat.* 127:115-124.
- Smiley, P.C., Jr., and G. R. Parsons. 1997. Effects of photoperiod and temperature on swimming performance of white crappie. *Trans. Am. Fish. Soc.* 126(3):495-499.
- Smith, G. R. 1992. Phylogeny and biogeography of the catostomidae, freshwater fishes of North America and Asia, p. 778-826. *In* Systematics, historical ecology, and North American freshwater fishes R. L. Mayden (ed.). Stanford Univ. Press, Stanford.
- Stalnaker, C., B. L. Lamb, J. Neriksen, K. Bovee, J. Bartholow. 1995. The instream flow incremental methodology: a primer for IFIM. National Biological Service, U.S. Department of Interior, Biological Report 29.

- Stauffer, J. R., Jr., J. M. Boltz, K. A. Kellog, and E. S. van Snik. 1996. Microhabitat partitioning in a diverse assemblage of darters in the Allegheny River system. *Environ. Biol. Fishes.* 46:37-44.
- Stoeckel, J. N. 1993. Controlled cultivation techniques for the recovery of threatened fish in Virginia. Dissertation, Virginia Polytechnic Institute and State University, Blacksburg, VA.
- Taylor, C. A., M. L. Warren, Jr., J. F. Fitzpatrick, Jr., H. H. Hobbs III, R. F. Jezerinac, W. L. Pflieger and H. W. Robison. 1996. Conservation status of crayfishes of the United States and Canada. *Fisheries.* 21(4):25-37.
- Taylor, E. B., and C. J. Foote. 1991. Critical swimming velocities of juvenile sockeye salmon and kokanee, the anadromous and non-anadromous forms of *Oncorhynchus nerka* (Walbaum). *J. Fish Biol.* 38:407-419.
- Temple, A. 1997. The effects of coal mining on sedimentation and fish assemblages in the Powell River, Virginia. Dissertation, Virginia Polytechnic Institute and State University, Blacksburg, VA.
- Terwilliger, K., J. R. Tate, and S. L. Woodward. 1995. A Guide to endangered and threatened species in Virginia. McDonald and Woodward Publishing Co., Blacksburg, VA.
- Thomas, J. A., and K. D. Bovee. 1993. Application and testing of a procedure to evaluate transferability of habitat suitability criteria. *Regulated Rivers.* 8: 285-294.
- TNC (The Nature Conservancy). 1997. 1997 species report card: The state of U.S. plants and animals. The Nature Conservancy, Arlington, VA.
- Toepfer, C. S., W. L. Fisher, J. A. Haubelt. 1999. Swimming performance of the threatened leopard darter in relation to road culverts. *Trans. Am. Fish. Soc.* 128:155-161.
- Tonn, W. M., J. J. Magnuson, M. Rask, and J. Toivonen. 1990. Intercontinental comparison of small-lake fish assemblages: the balance between local and regional processes. *Am. Natur.* 136(3):345-375.
- Townsend, C. R., S. Doledec, and M. R. Scarsbrook. 1997. Species traits in relation to temporal and spatial heterogeneity in streams: A test of habitat templet theory. *Freshwater Biol.* 37 (2):367-387.
- Trautman, M. B. 1981. The Fishes of Ohio. Ohio State Univ., Columbus.

- Triantafyllou, M. S., Triantafyllou, G. S., and D. K. P. Yue. 2000. Hydrodynamics of fishlike swimming. *Annu. Rev. Fluid Mech.* 32:33-53.
- Vadas, R. L., Jr. 1994. Habitat tools for assessing instream-flow needs for fishes in the upper Roanoke River, Virginia. Ph.D. Dissertation. Virginia Polytechnic Institute and State University, Blacksburg, VA.
- , and D. J. Orth. 1997. Species associations and habitat use of stream fishes: the effects of unaggregated-data analysis. *J. Freshwater Ecol.* 12(1):27-37.
- , and -----. 1998. Use of physical variables to discriminate visually determined mesohabitat types in North American streams. *Rivers* 6(3):143-159.
- , and -----. 2000. Habitat use of fish communities in a Virginia stream system. *Environ. Biol. Fishes* 59:253-269.
- Van Winkle, W., C. C. Coutant, H. I. Jager, J. S. Mattice, D. J. Orth, R. G. Otto, S. F. Railsback, and M. J. Sale. 1997. Uncertainty and instream flow standards: Perspectives based on hydropower research and assessment. *Fisheries*. 22(7):21-22.
- Videler, J. J. 1993. *Fish swimming*. Chapman and Hall, London, New York.
- , and C. S. Wardle. 1991. Fish swimming stride by stride: speed limits and endurance. *Reviews Fish Biol. Fish.* 1:23-40.
- Vogel, S. 1994. *Life in moving fluids: the physical biology of flow*. Princeton Univ., Princeton, NJ.
- Vörösmarty, C. J., P. Green, J. Salisbury, and R. B. Lammers. 2000. Global Water Resources: Vulnerability from Climate Change and Population Growth. *Science*. 289(5477): 284-288.
- Wainwright, P. C. 1991. Ecomorphology: experimental functional anatomy for ecological problems. *Am. Zool.* 31:680-693.
- , and G. V. Lauder. 1992. The evolution of feeding biology in sunfishes (Centrarchidae), p. 472-491. *In* Systematics, historical ecology, and North American freshwater fishes. R. L. Mayden (ed.). Stanford Univ. Press, Stanford.
- Walser, C. A., and H. L. Bart, Jr. 1999. Influence of agriculture on in-stream habitat and fish community structure in Piedmont watersheds of the Chattahoochee River system. *Ecol. Freshwat. Fish* 8:237-246.

- Warren, M. L., Jr., and M. G. Pardew. 1998. Road crossings as barriers to small-stream fish movement. *Trans. Am. Fish. Soc.* 127:637-644.
- , B. M. Burr, S. J. Walsh, H. L. Bart Jr., R. C. Cashmer, D. A. Etnier, B. J. Freeman, B. R. Kuhajda, R. L. Mayden, H. W. Robison, S. T. Ross, and W. C. Starnes. 2000. Diversity, distribution, and conservation status of the native freshwater fishes of the southern United States. *Fisheries* 25(10):7-31.
- Watson, D. J., and E. K. Balon. 1984. Ecomorphological analysis of fish taxocenes in rainforest streams of northern Borneo. *J. Fish Biol.* 25:371-384.
- Webb, P. W. 1984. Form and function in fish swimming. *Sci. Am.* 251:72-75.
- Welsh, S. A., and S. A. Perry. 1998a. Influence of spatial scale on estimates of substrate use by benthic darters. *N. Am. J. Fish. Manag.* 18(4):954-959.
- , and ----- . 1998b. Habitat partitioning in a community of darters in the Elk River, West Virginia. *Environ. Biol. Fishes* 51:411-419.
- Werner, E. E., and D. J. Hall. 1988. Ontogenetic habitat shifts in bluegill: the foraging rate-predation risk trade-off. *Ecology.* 69(5):1352-1366.
- Wetmore, S. H., R. J. Mackay, and R. W. Newbury. 1990. Characterization of the hydraulic habitat of *Brachycentrus occidentalis*, a filter-feeding caddisfly. *J. N. Am. Benthol. Soc.* 9(2):157-169.
- Wikramanayake, E. D. 1990. Ecomorphology and biogeography of a tropical stream fish assemblage: evolution of assemblage structure. *Ecology* 71(5):1756-1764.
- Wiley, E. O., and R. L. Mayden. 1985. Species and speciation in phylogenetic systematics with examples from the North American fish fauna. *Annals Missouri Bot. Garden* 72:596-635.
- Williams, D. D., N. E. Williams, and Y. Cao. 2000. Road salt contamination of groundwater in a major metropolitan area and development of a biological index to monitor its impact. *Water Res.* 34(1):127-138.
- Williams, I. V., and J. R. Brett. 1987. Critical swimming speed of Fraser and Thompson River Pink Salmon (*Oncorhynchus gorbuscha*). *Can. J. Fish. Aquatic Sci.* 44:348-356.
- Williams, J. G., T. P. Speed, and W. F. Forrest. 1999. Comment: Transferability of habitat suitability criteria. *N. Am. J. Fish. Manag.* 19:623-625.

- Wong, T. S. W., and Y. Li. 1999. Theoretical assessment of changes in design flood peak of an overland plane for two opposing urbanization sequences. *Hydrol. Process.* 13(11):1629-1647.
- Wood, B. M., and M. B. Bain. 1995. Morphology and microhabitat use in stream fish. *Can. J. Fish. Aquat.* 52:1487-1498.
- Wood, R. M. 1996. Phylogenetic systematics of the darter subgenus *Nothonotus* (Teleostei: Percidae). *Copeia.* 1996(2):300-318.
- , and R. L. Mayden. 1997. Phylogenetic relationships among selected darter subgenera (Teleostei:Percidae) as inferred from analysis of allozymes. *Ibid.*. 1997(2):265-274.
- Woodman, D. A. 1992. Systematic relationships within the cyprinid genus *Rhinichthys*, p. 374-392. *In* Systematics, historical ecology, and North American freshwater fishes. R. L. Mayden (ed.). Stanford Univ. Press, Stanford.

Appendix A. Morphology measurements

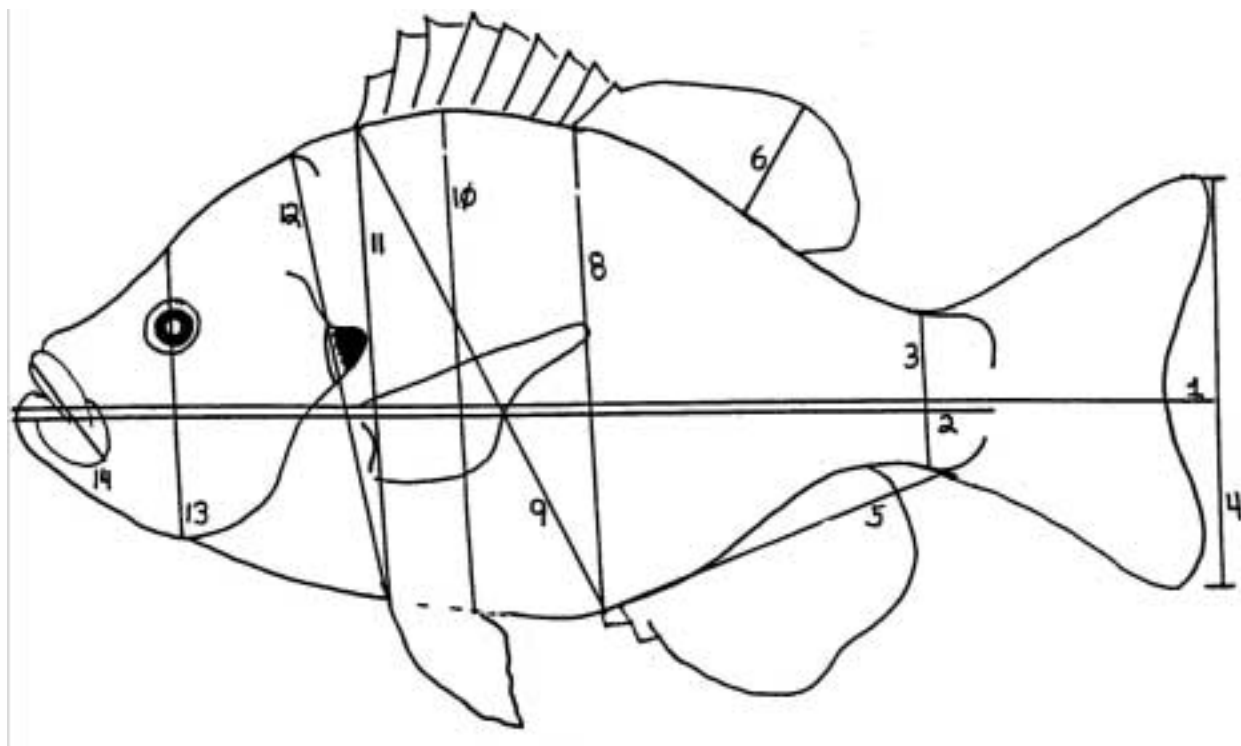

Figure A.1. Diagram with the first fifteen morphology measurements used in this study (the remainder are illustrated in Figure A.2): 1) total length (TL), 2) standard length (SL), 3) anterior caudal fin depth (VMCFDMCF), 4) posterior caudal fin depth (CFD), 5) distance from anal fin to caudal fin (AFVMCF), 6) maximum dorsal fin span (MDFS), 7) maximum body width (not shown) (MBW), 8) distance from posterior of dorsal fin to anal fin (PDFAF), 9) distance from dorsal fin to anal fin (ADFAF), 10) maximum body depth (MBD), 11) distance from dorsal fin to pelvic fin (ADFPEL), 12) distance from posterior of neurocranium to pelvic fin (PNERPEL), 13) head depth (HD), and 14) upper jaw length (JMAX). References for measurements are as follows: 1, 2, 4, 6, 10 (Bandyopadhyay et al., 1997); 7, 13 (Watson and Balon, 1984); and 3, 5, 8, 9, 11, 12, 14 (Wood and Bain, 1995).

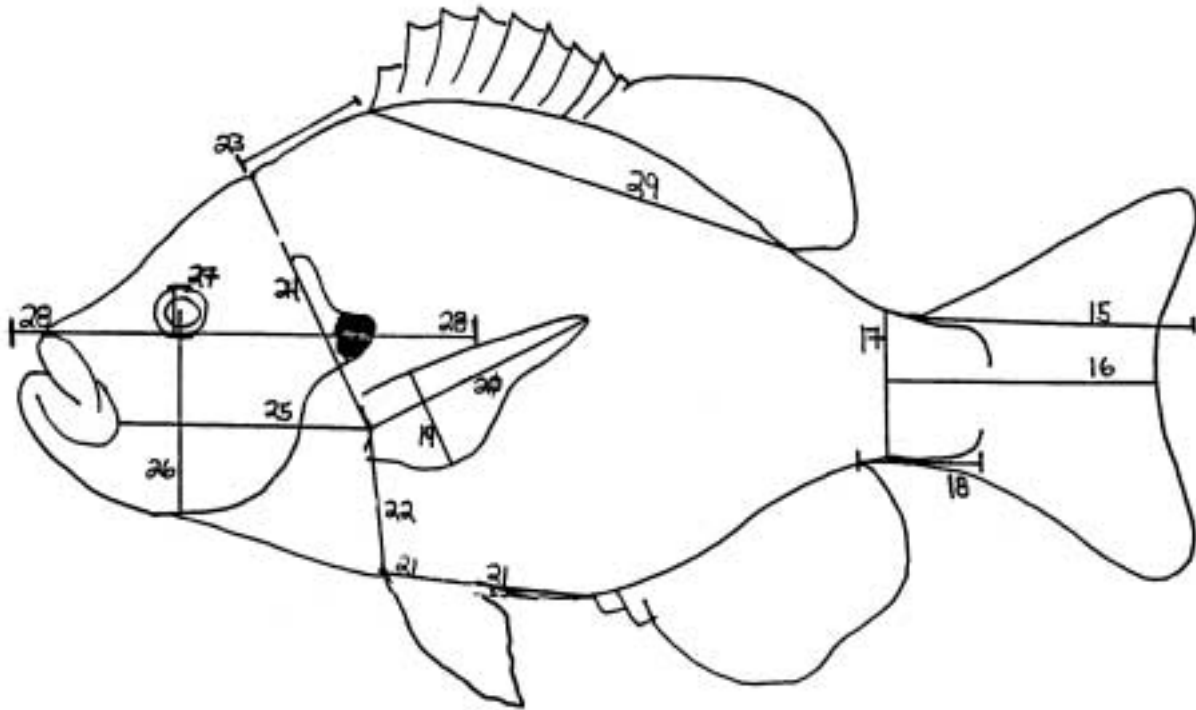

Figure A.2. Diagram illustrating remaining morphology measurements taken for this study (other measurements are illustrated in Figure A.1 of Appendix A): 15) caudal fin length (CFL), 16) axial caudal fin length (ACFL), 17) caudal peduncle depth (CPD), 18) caudal peduncle length (CPL), 19) pectoral fin width (PFW), 20) pectoral fin length (PFL), 21) distance from pelvic fin to anal fin (PELAF), 22) distance from pectoral fin to pelvic fin (PECPEL), 23) pre-dorsal fin length (PNERDF), 24) distance from posterior of neurocranium to pectoral fin (PNERPEC), 25) distance from jaw to pectoral fin (MAXPEC), 26) eye position (EP), 27) eye diameter (EYESIZ), 28) distance from most anterior point of body to the point of greatest body depth (ALEEVY), 29) total length of dorsal fins (TLDF), and 30) caudal peduncle width (not shown) (CPW). References for measurements are as follows: 16, 29 (Bandyopadhyay et al., 1997); 15, 17, 18, 19, 20, 26, 30 (Watson and Balon, 1984); 21, 22, 23, 24, 25 (Wood and Bain, 1995); 28 (Alevy, 1969); and 27 (Gatz, 1979b).

Table A.1. List of variables (ratios) calculated from original morphology measurements. For instructions on how to take original measurements see Figures A.1 and A.2 in Appendix A.

Variable	Calculation
MDFSMBD	Maximum dorsal fin span (MDFS) / maximum body depth (MBD)
TRUNK	Streamlining: Alev's 'y' measurement (ALEEVY) / standard length (SL)
PECAREA	Pectoral fin area: width (PFW) * length (PFL)
PECASP	Pectoral fin aspect: length (PFL) / (PFW)
EYELOC	Eye position (EP) / head depth (HD)
EYESIZHD	Eye size (EYESIZ) / head depth (HD)
CFDMBD	Caudal fin depth (CFD) / maximum body depth (MBD)
MBDMBW	Maximum body depth (MBD) / maximum body width (MBW)
CFAREA2	Caudal fin area, [width (CFW) * length (CFL)] / standard length (SL)
CFASP	Caudal fin aspect, length (CFL) / width (CFD)
CFASP2	Caudal fin aspect, also, caudal fin depth (CFD) / caudal fin length (CFL)]
CFASP22	Caudal fin aspect (CFASP) / standard length (SL)
CPINDEX	Caudal peduncle compression index, depth (CPD) / width (CPW)

Appendix B. Box plots

Box plots of morphology measurements for species of the Ronaoke River. Morphology measurements and their acronyms are total length (TL), standard length (SL), axial caudal fin length (ACFL), caudal fin depth (CFD), maximum body depth (MBD), total length of dorsal fin(s) (TLDF), maximum dorsal fin span (MDFS), maximum body width (MBW), caudal peduncle depth (CPD), caudal peduncle width (CPW), head depth (HD), pectoral fin width (PFW), pectoral fin length (PFL), eye position (EP), distance from dorsal fin to anal fin (ADFAF), distance from posterior of dorsal fin to anal fin (PDFAF), upper jaw length (JMAX), pre-dorsal fin length (PNERDF), distance from anal fin to caudal fin (AFVMCF), distance from pectoral fin to pelvic fin (PECPEL), distance from posterior of neurocranium to pectoral fin (PNERPEC), distance from dorsal fin to pelvic fin (ADFPEL), anterior caudal fin depth (VMCFDMCF), distance from neurocranium to pelvic fin (PNERPEL), distance from jaw to pectoral fin (MAXPEC), distance from pelvic fin to anal fin (PELAF), distance from most anterior point of body to the point of greatest body depth (ALEEVY), eye diameter (EYESIZE), caudal peduncle length (CPL), and caudal fin length (CFL).

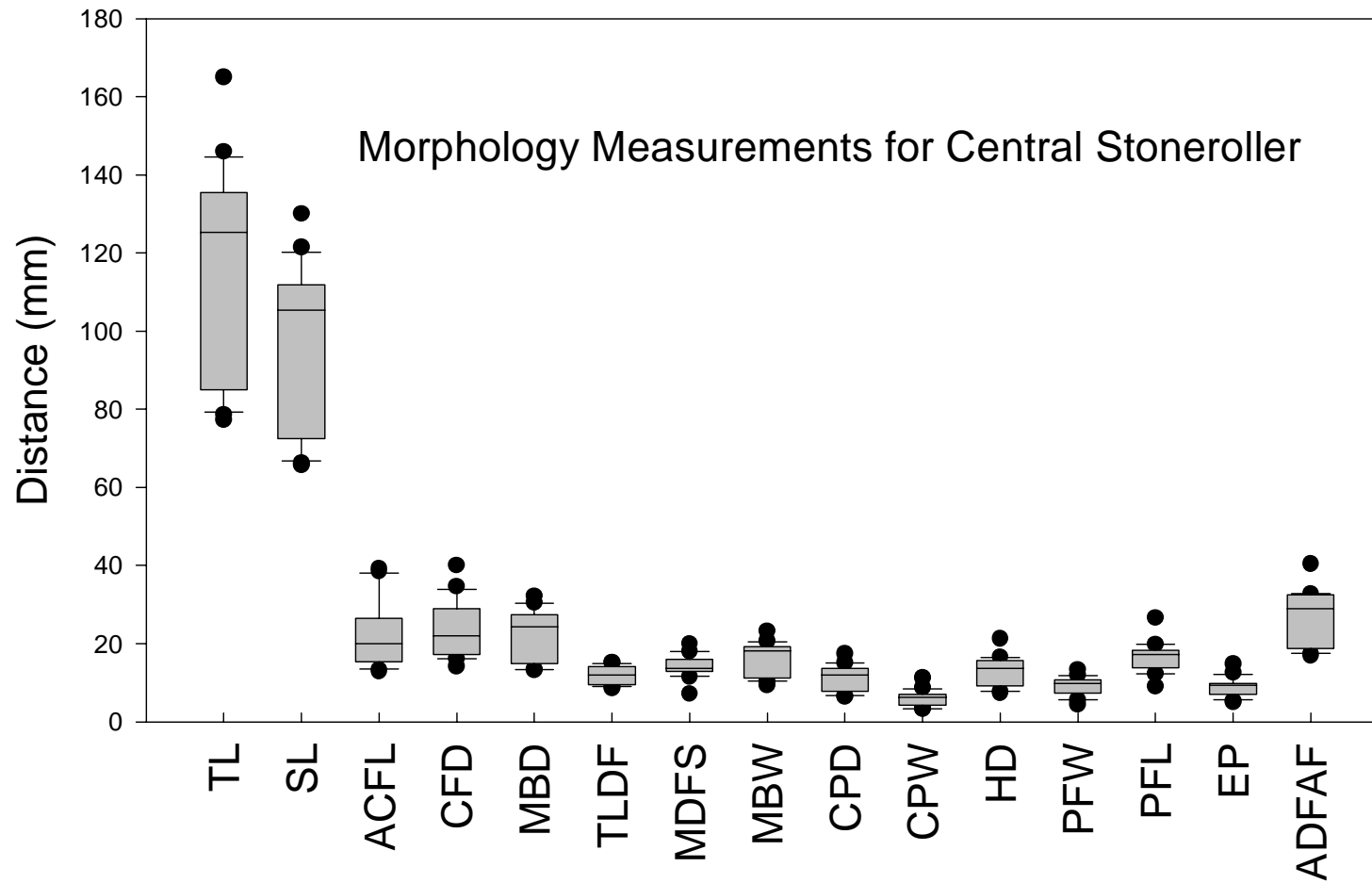

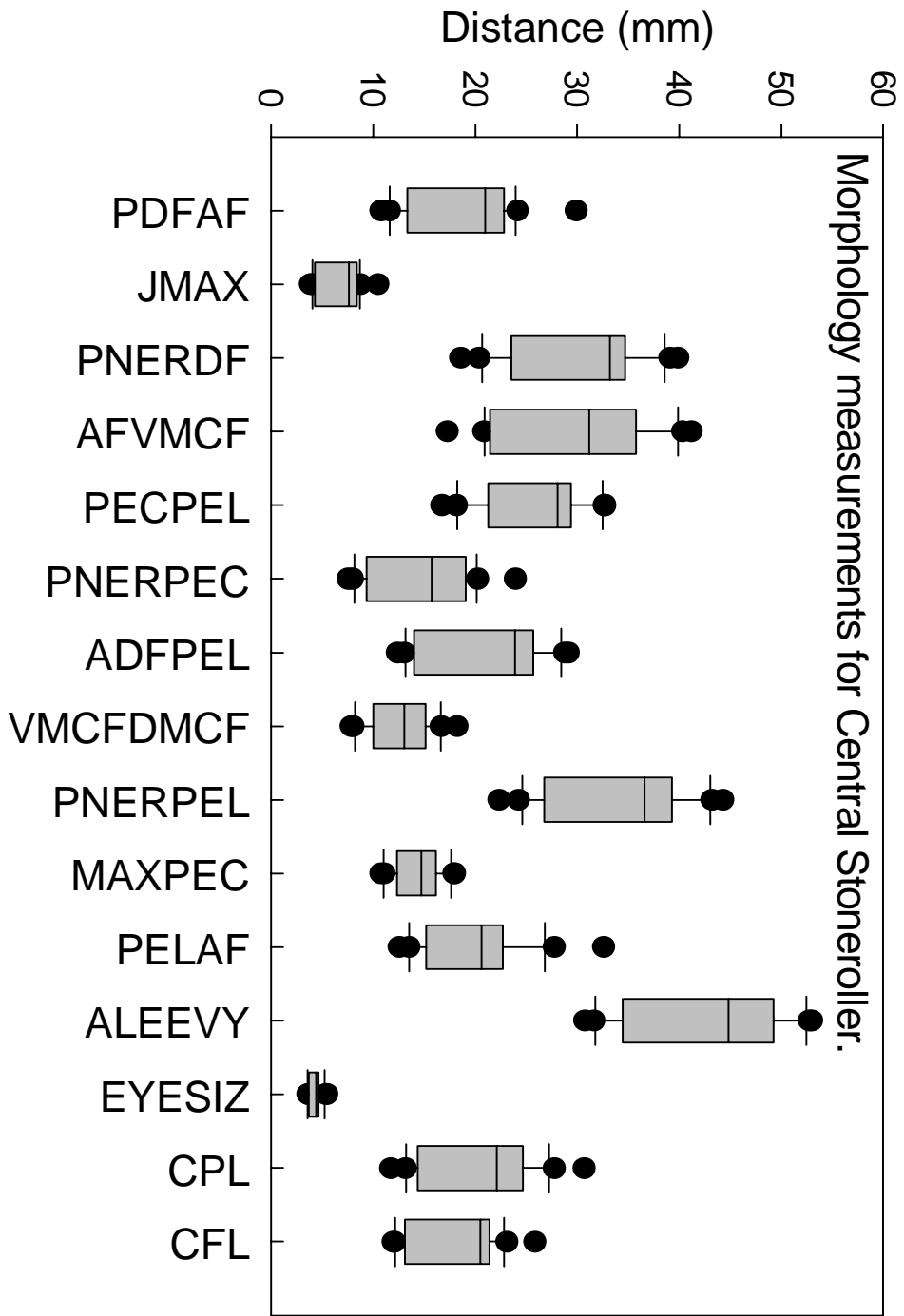

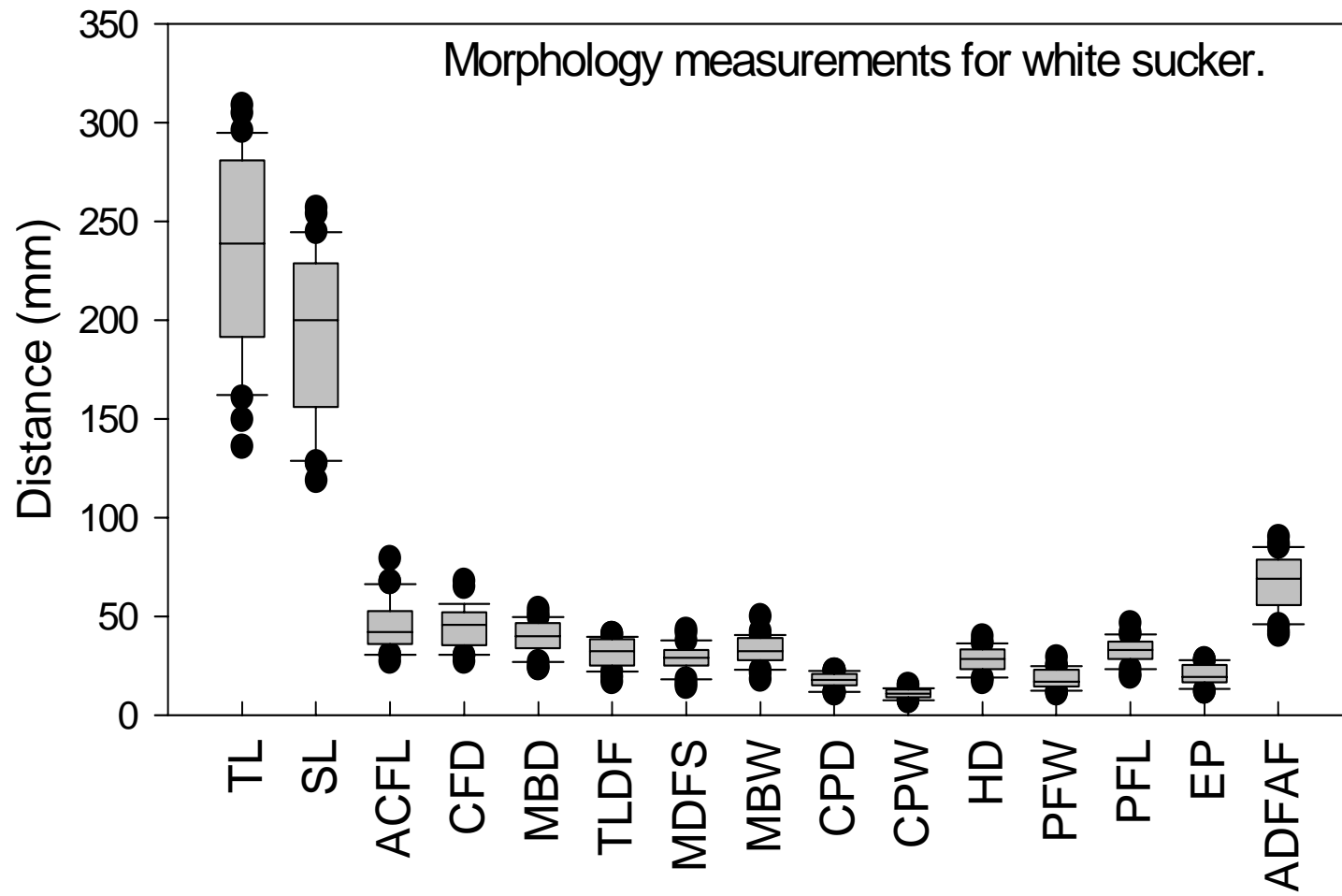

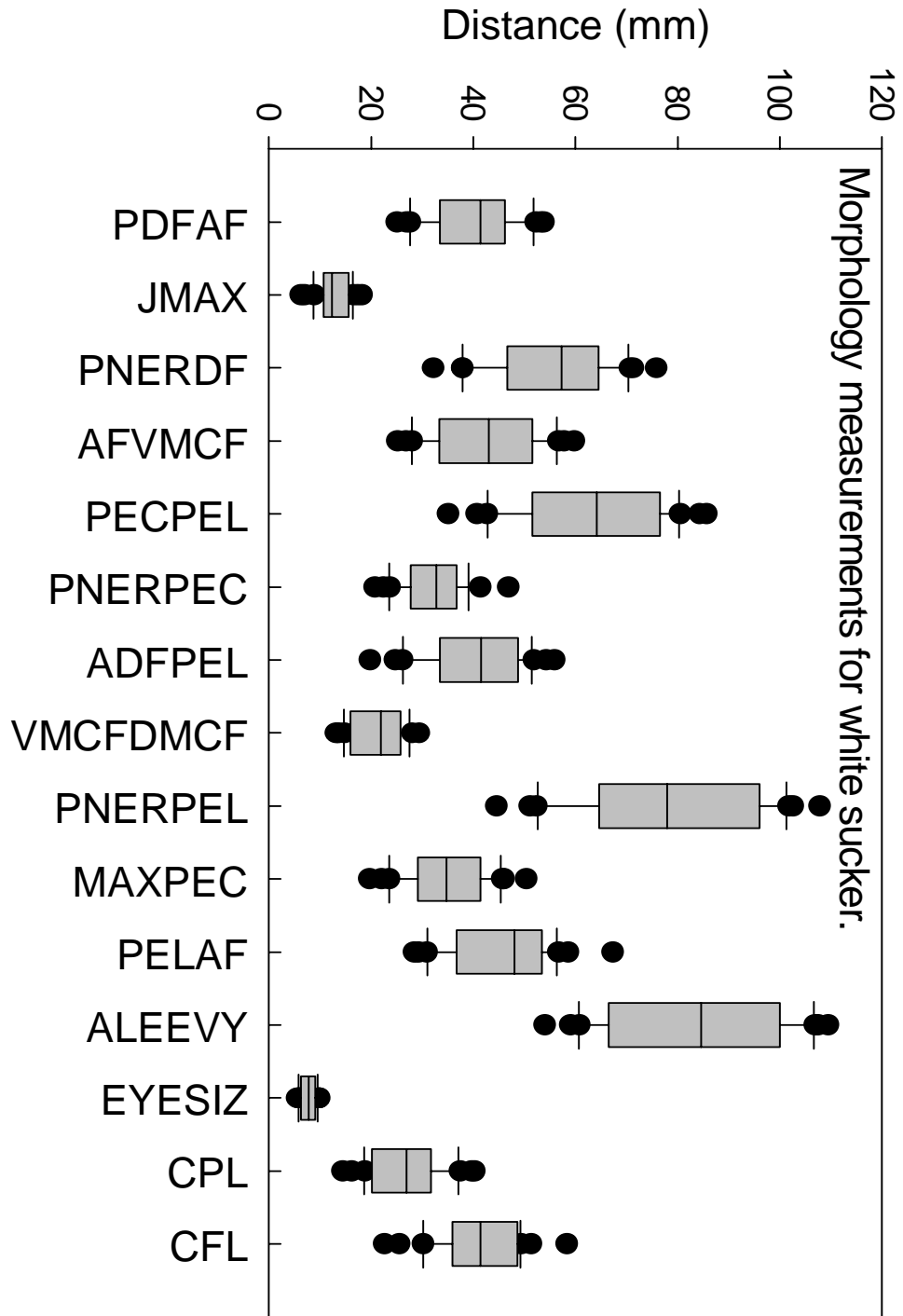

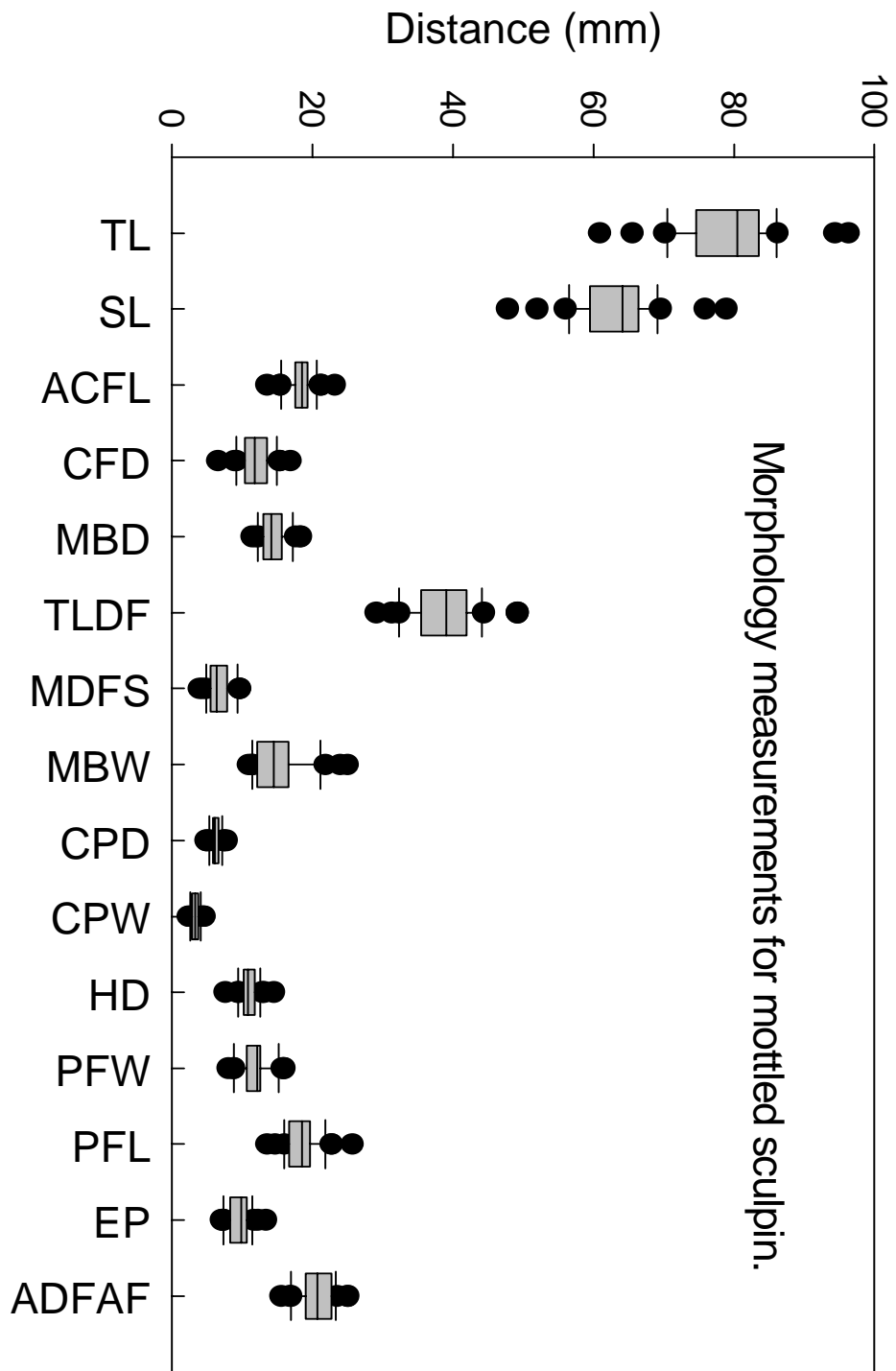

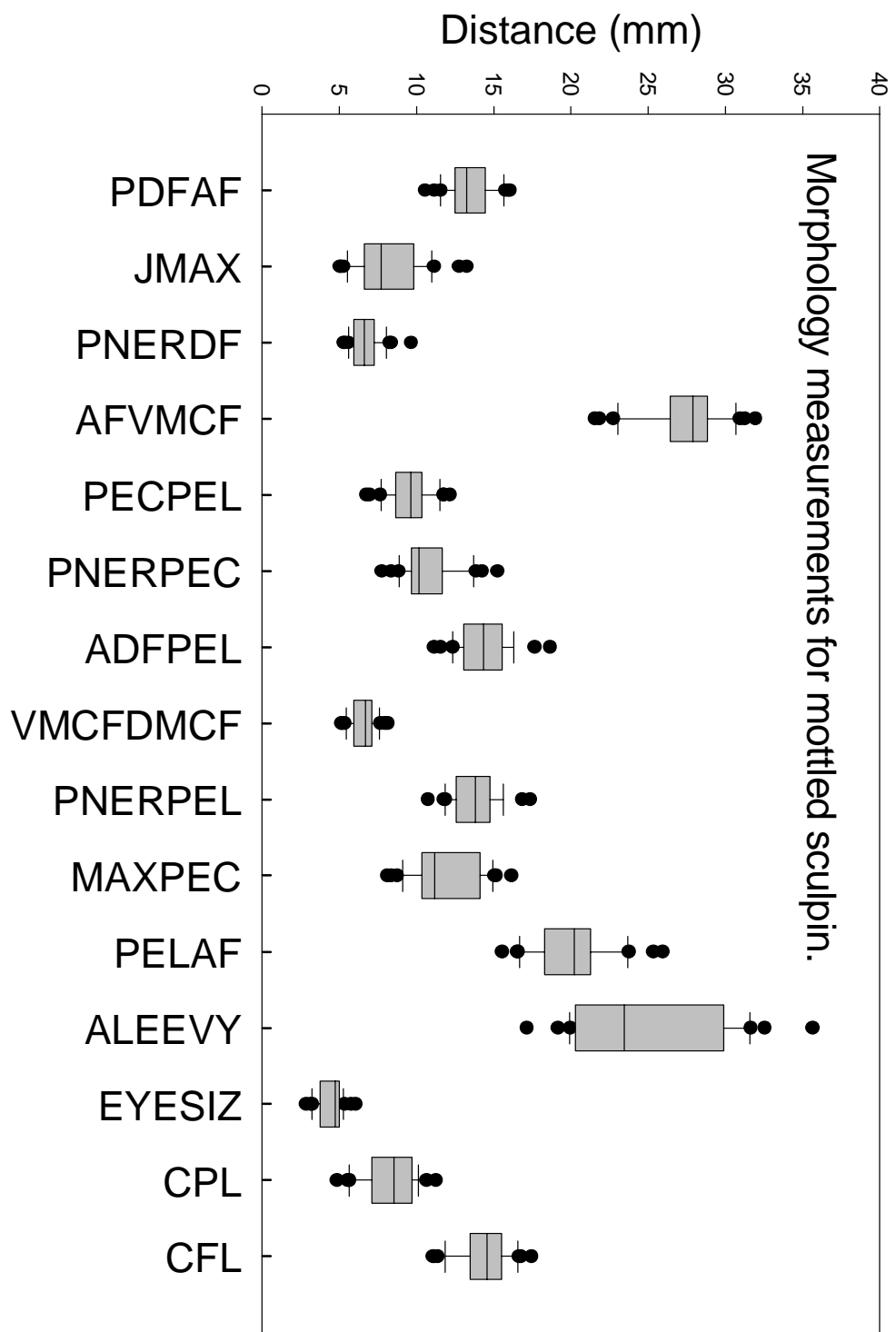

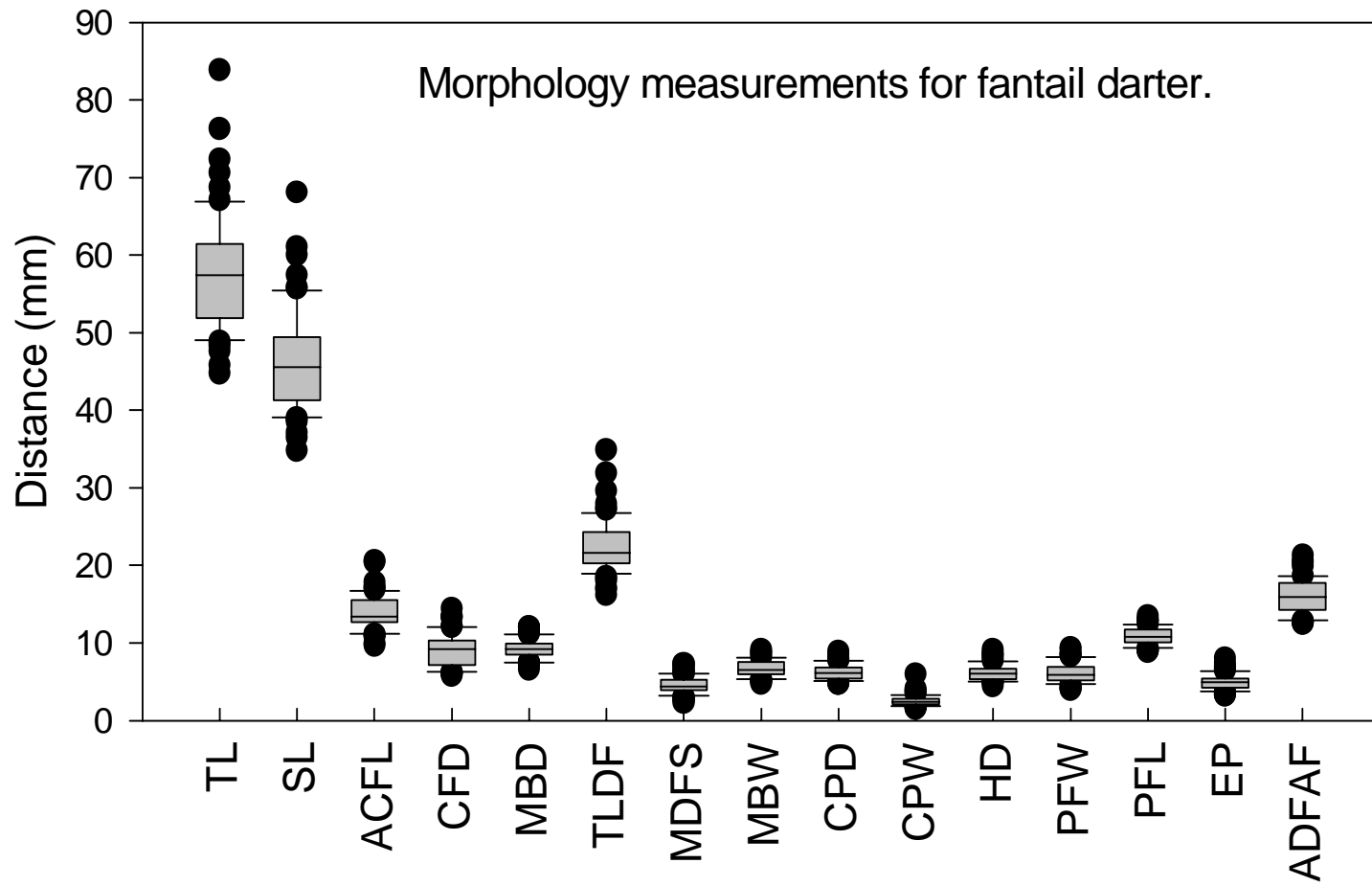

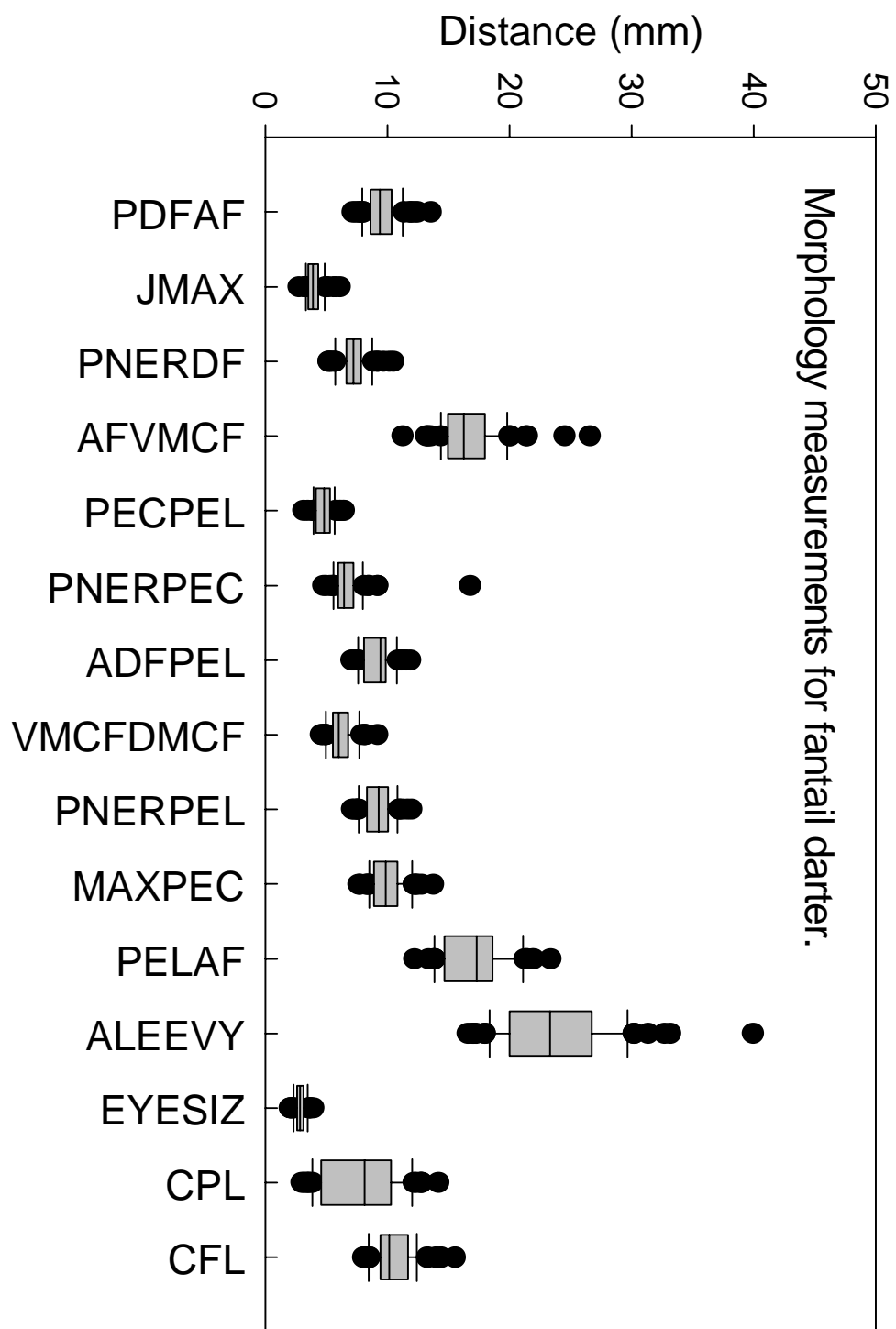

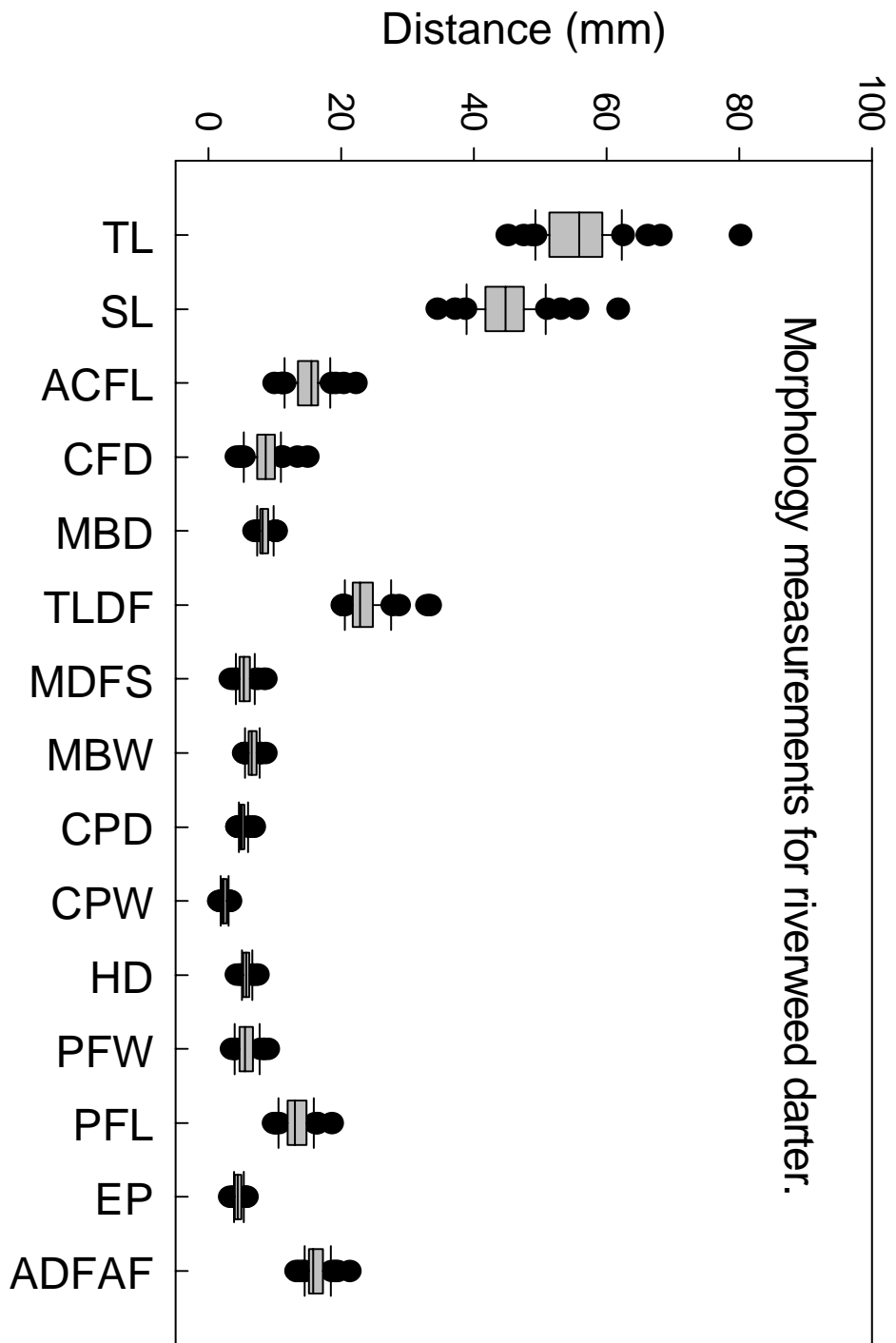

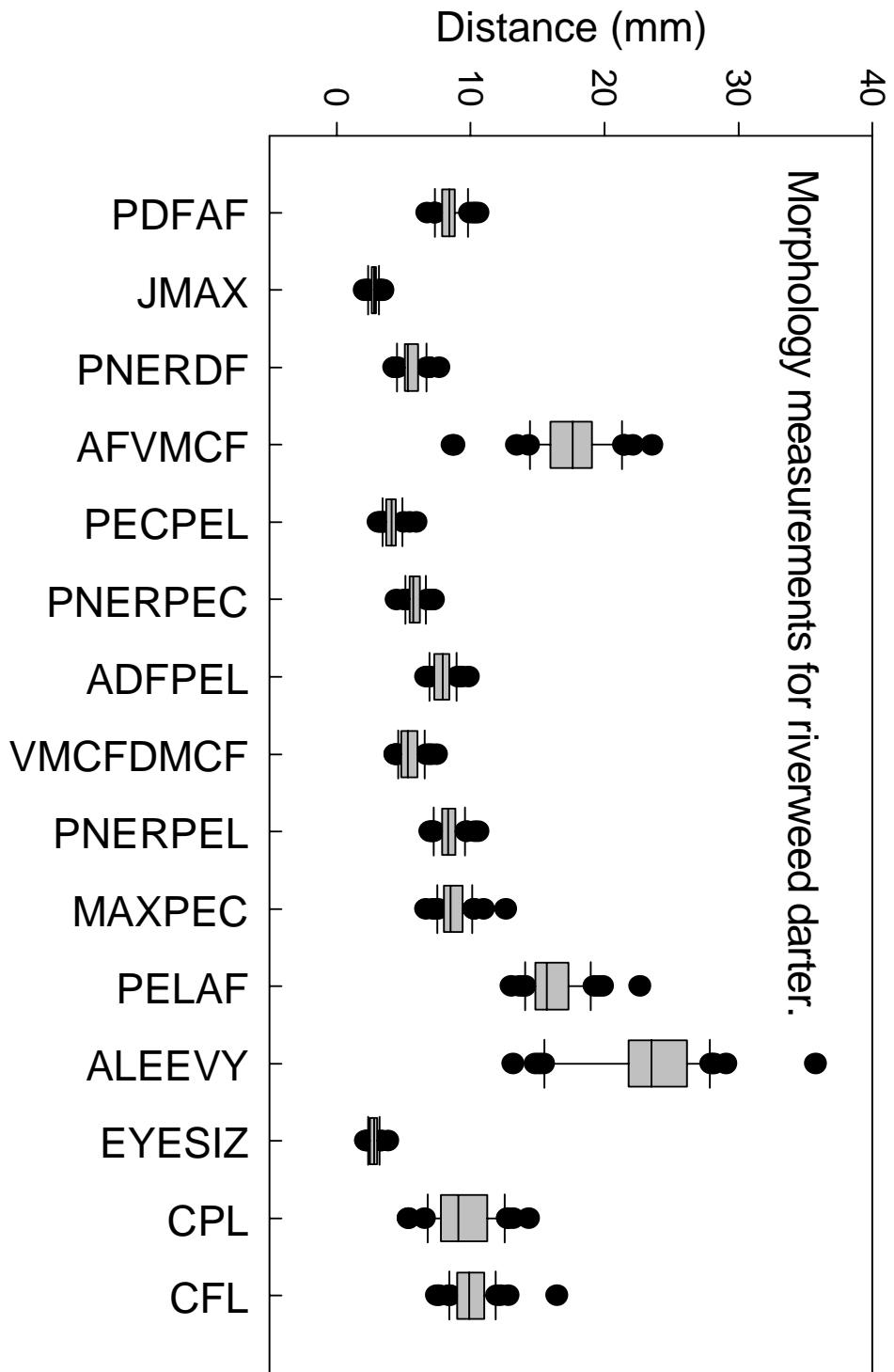

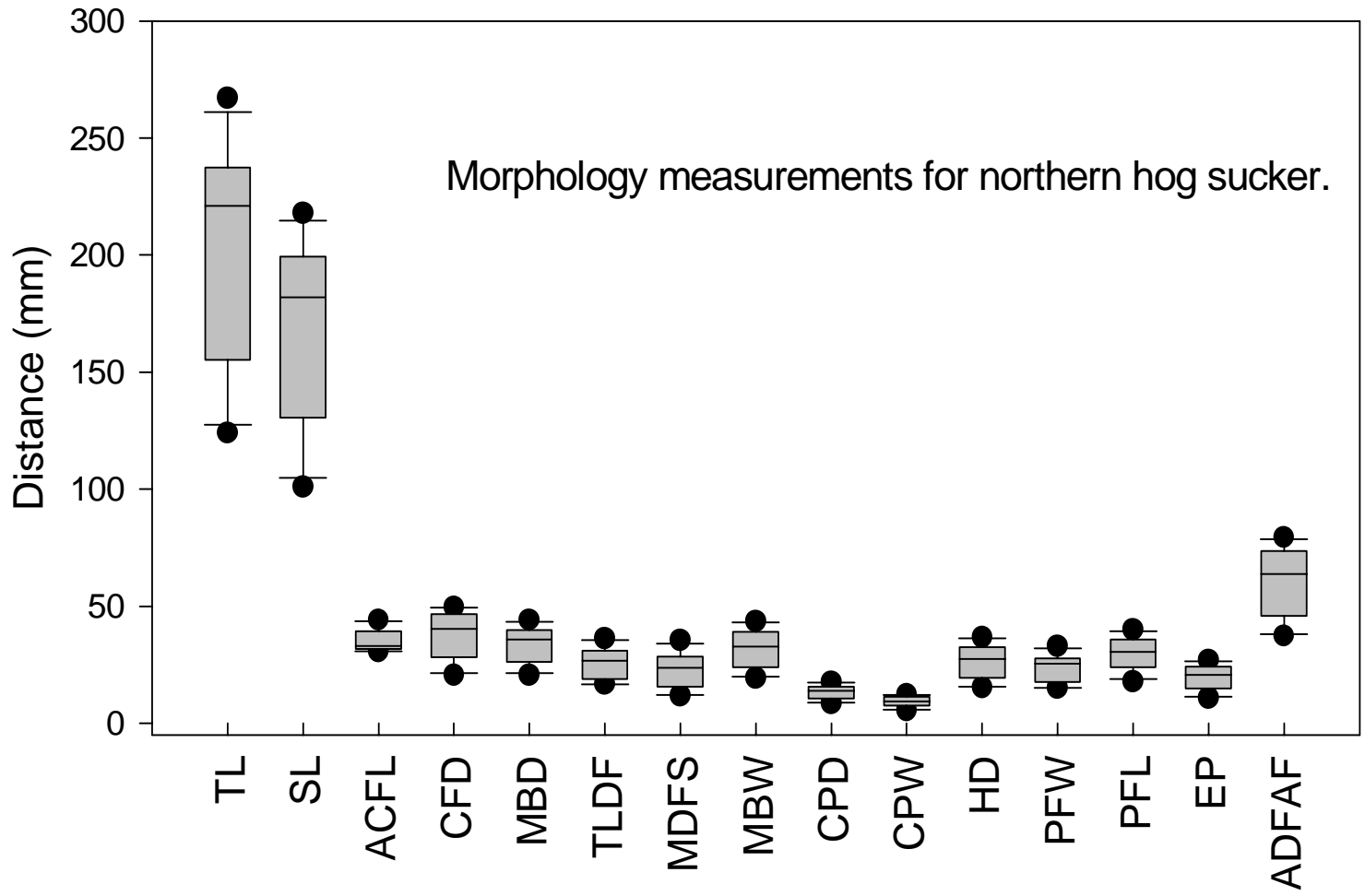

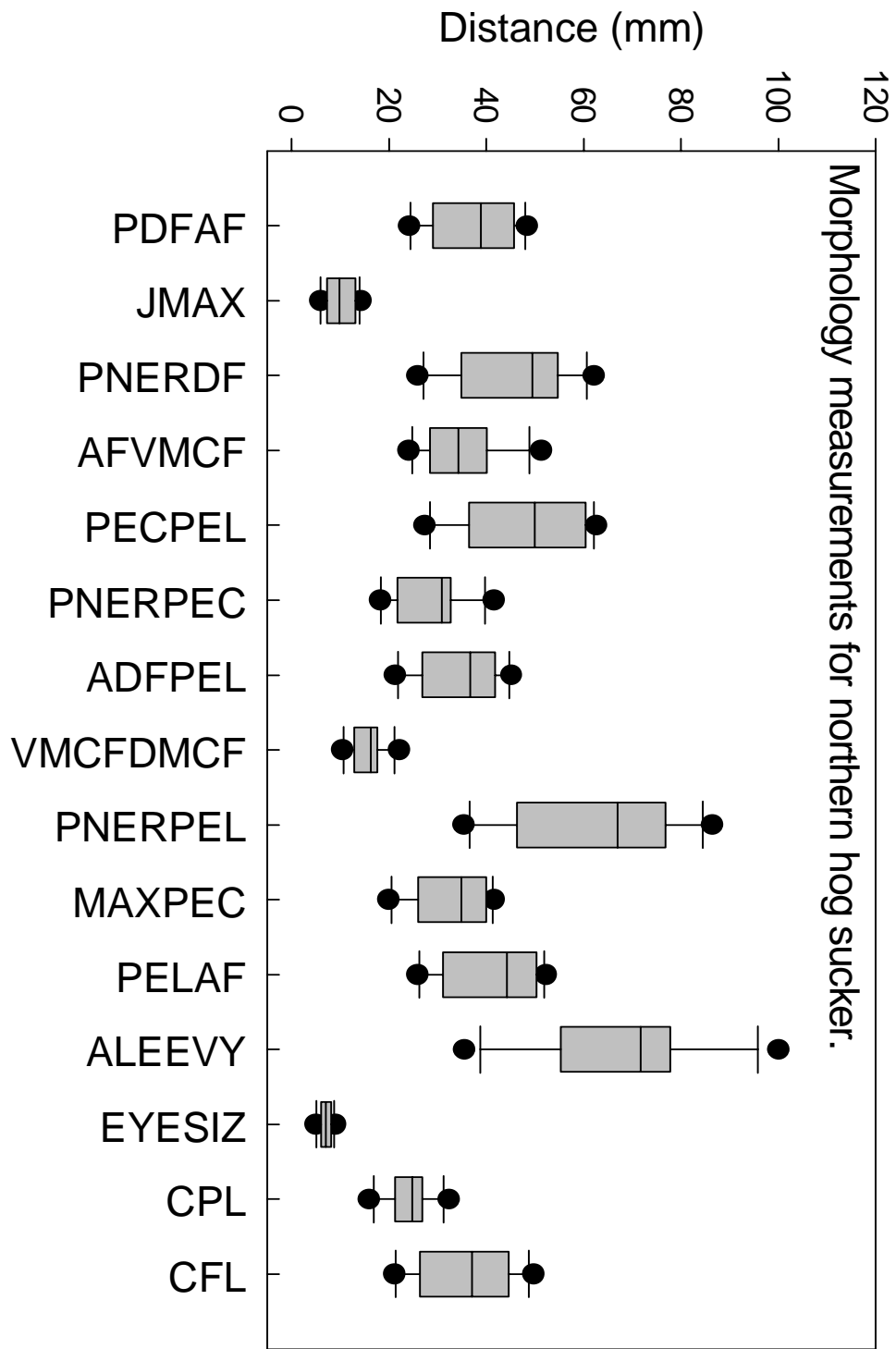

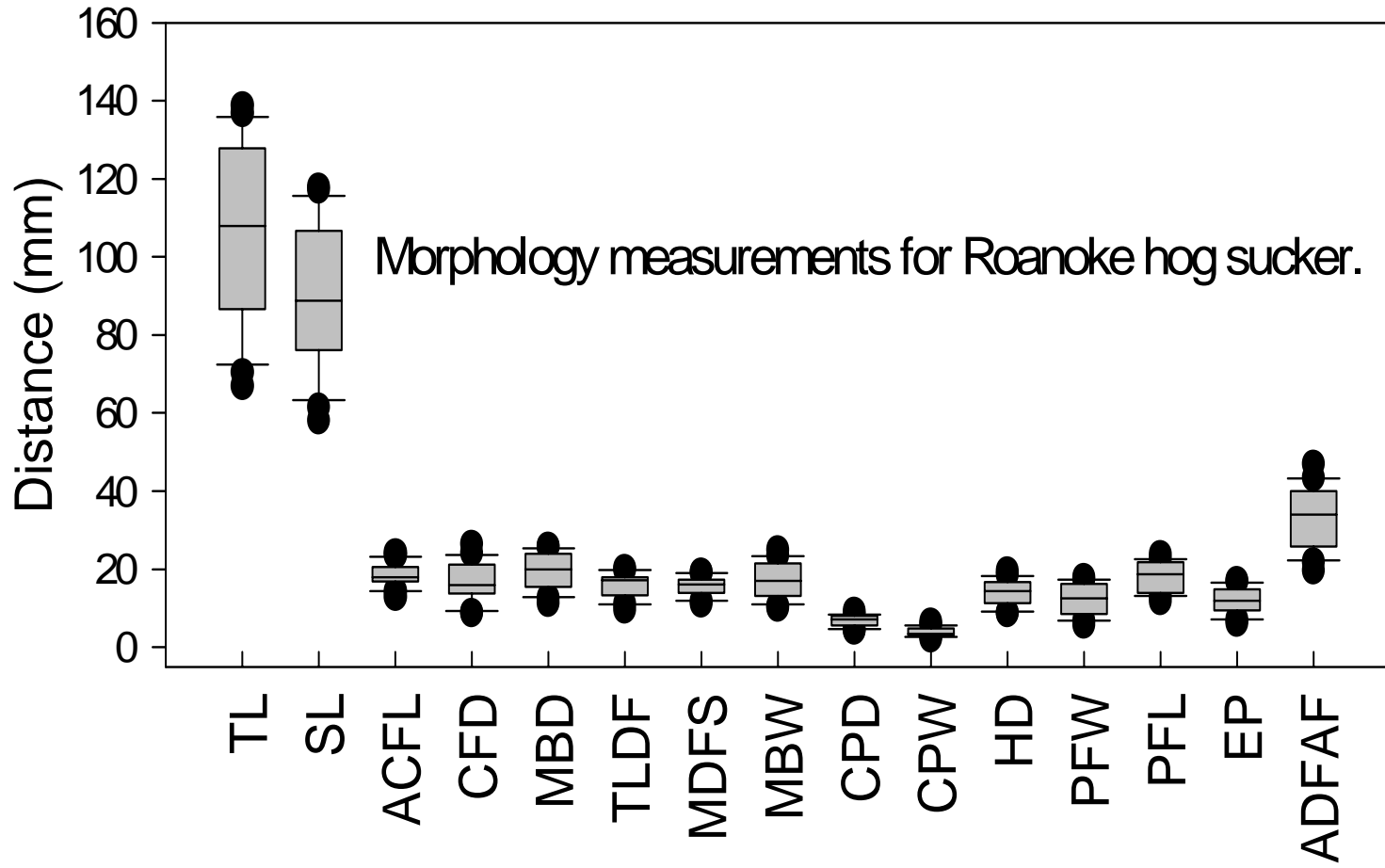

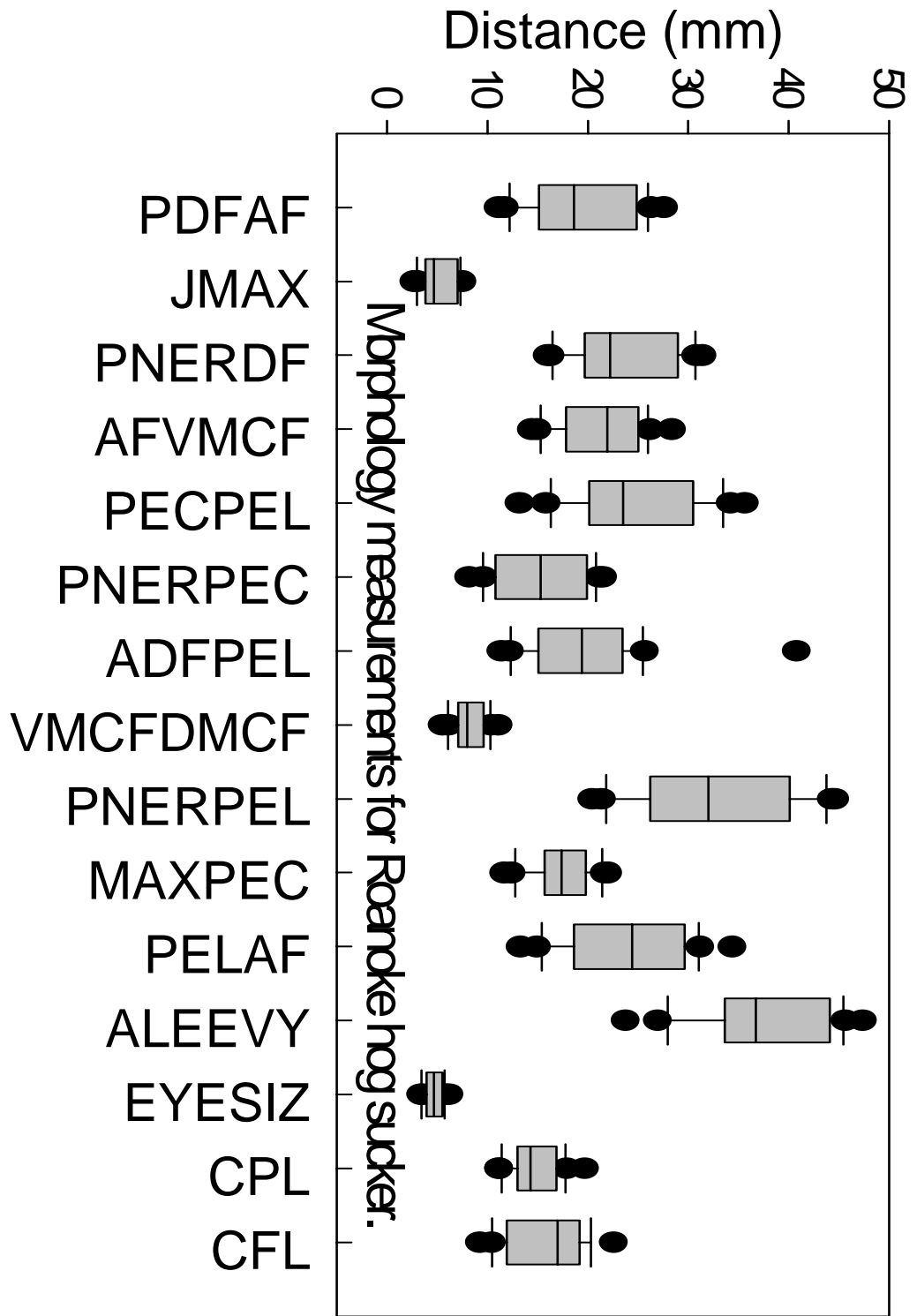

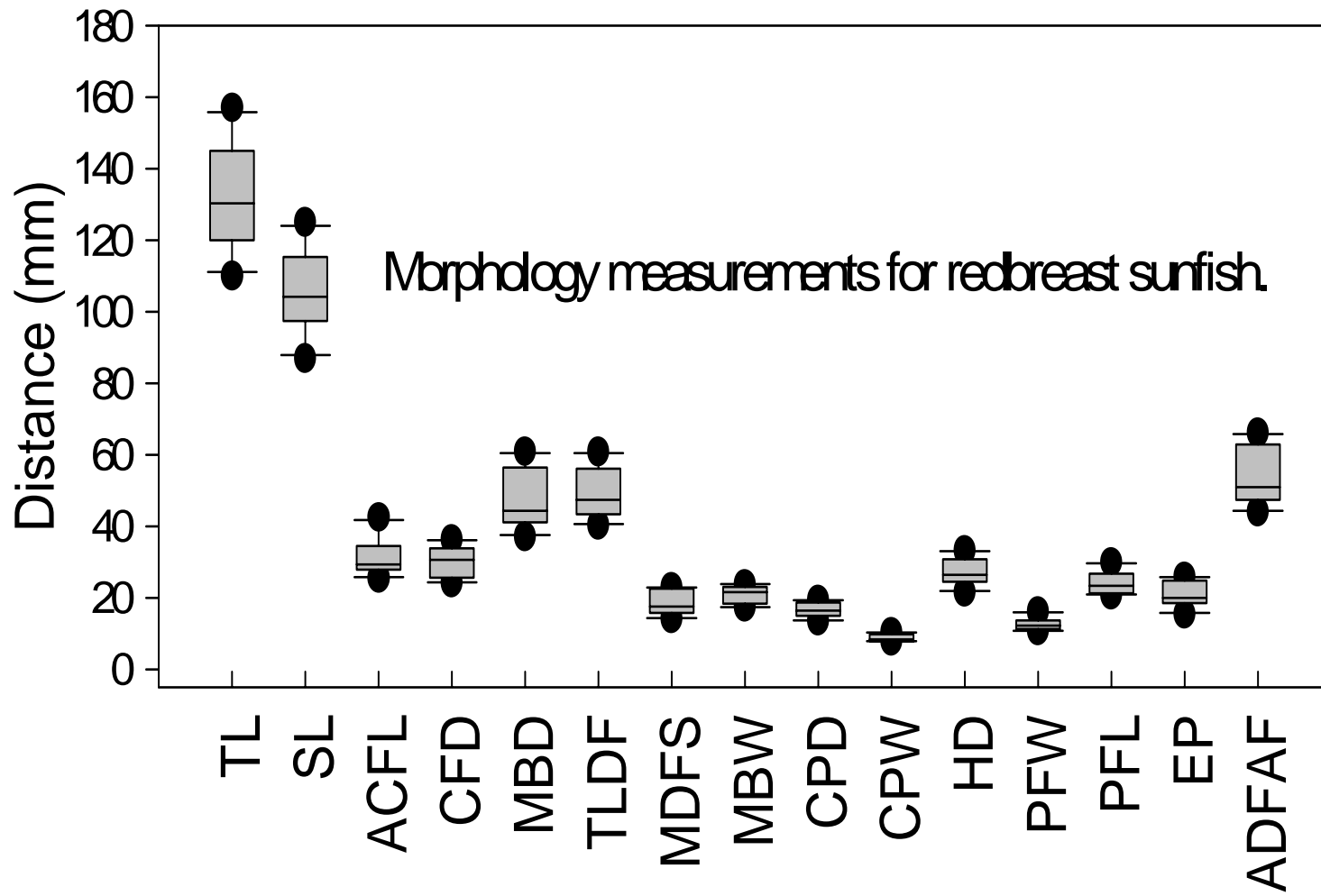

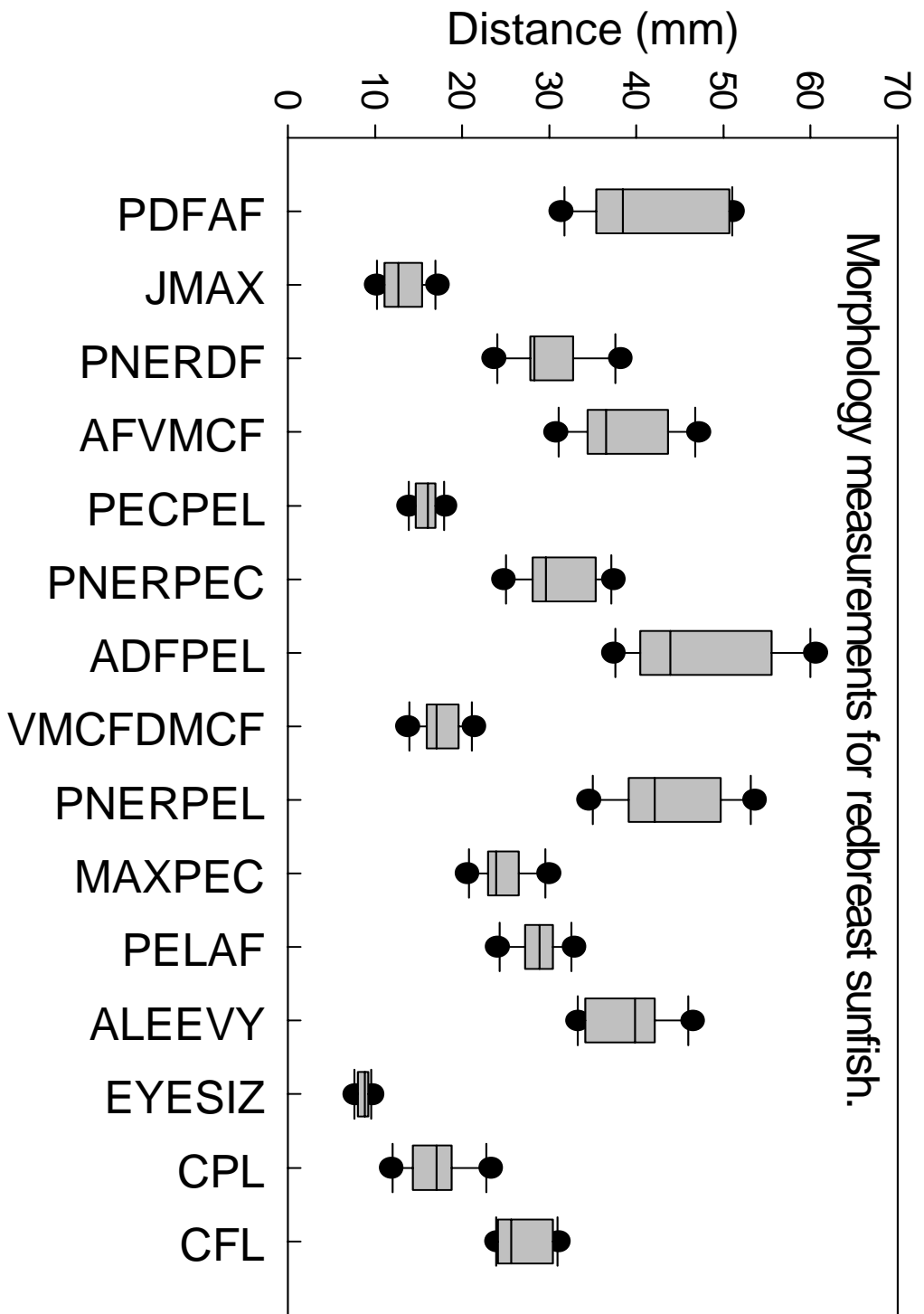

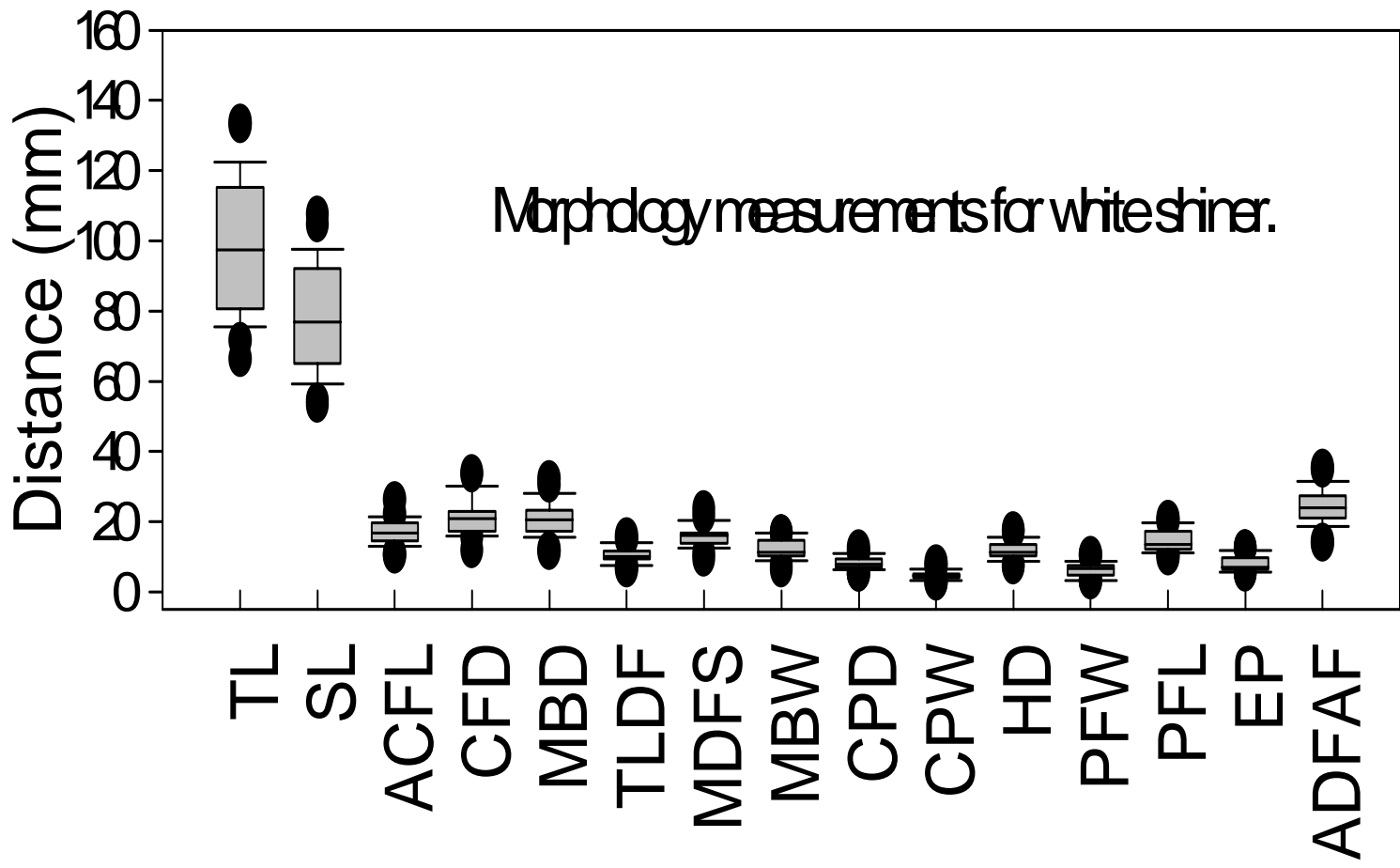

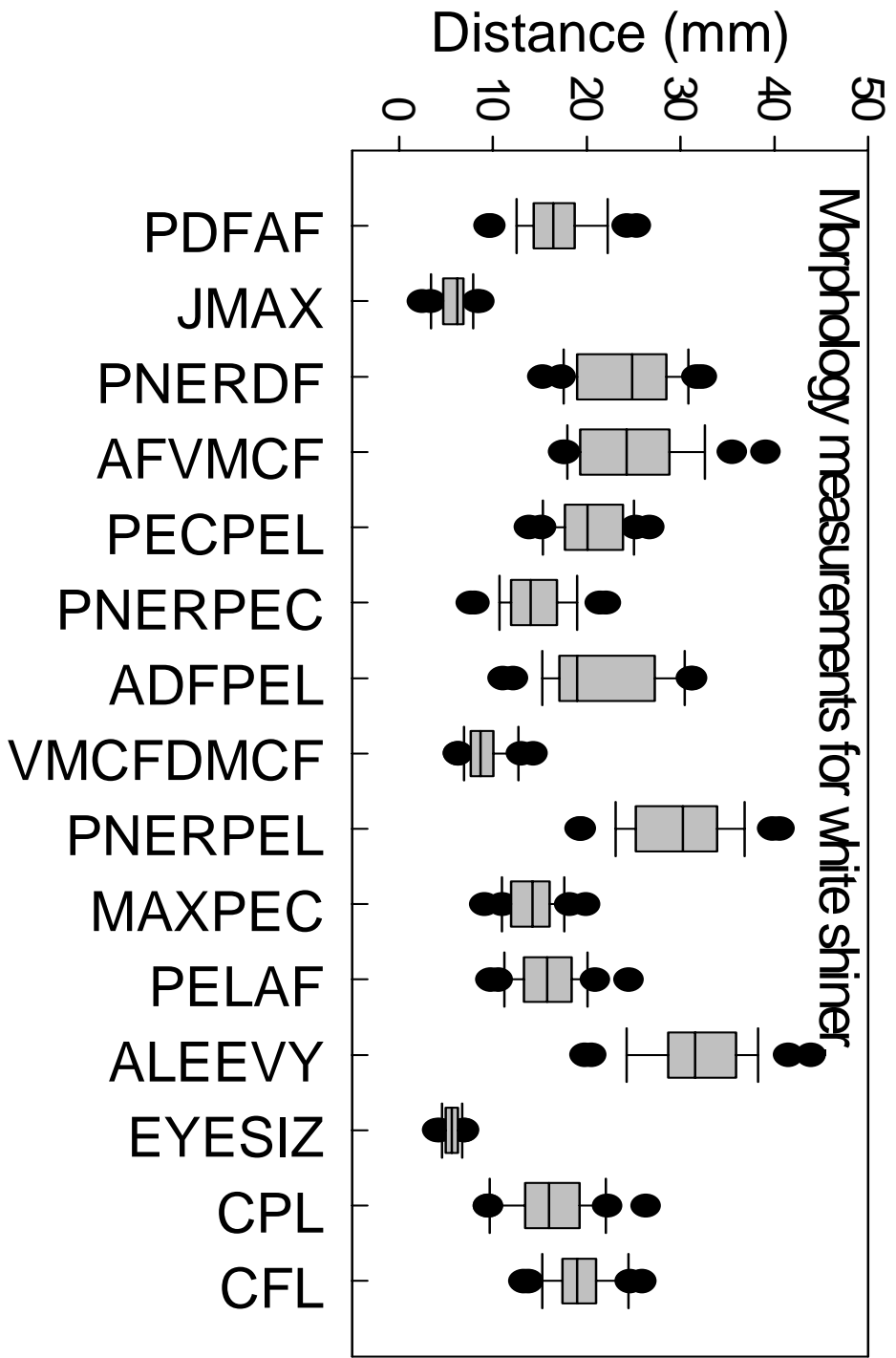

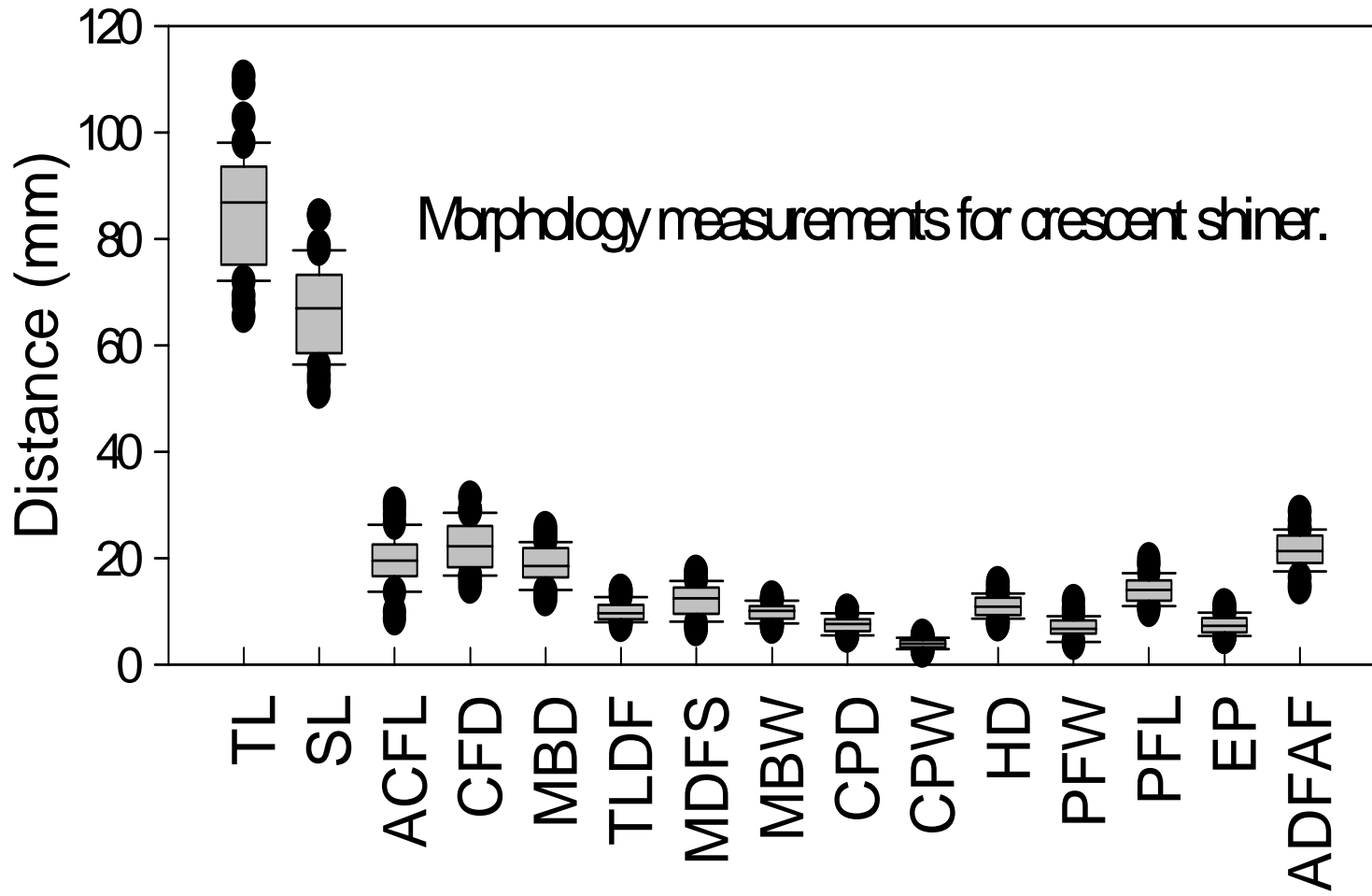

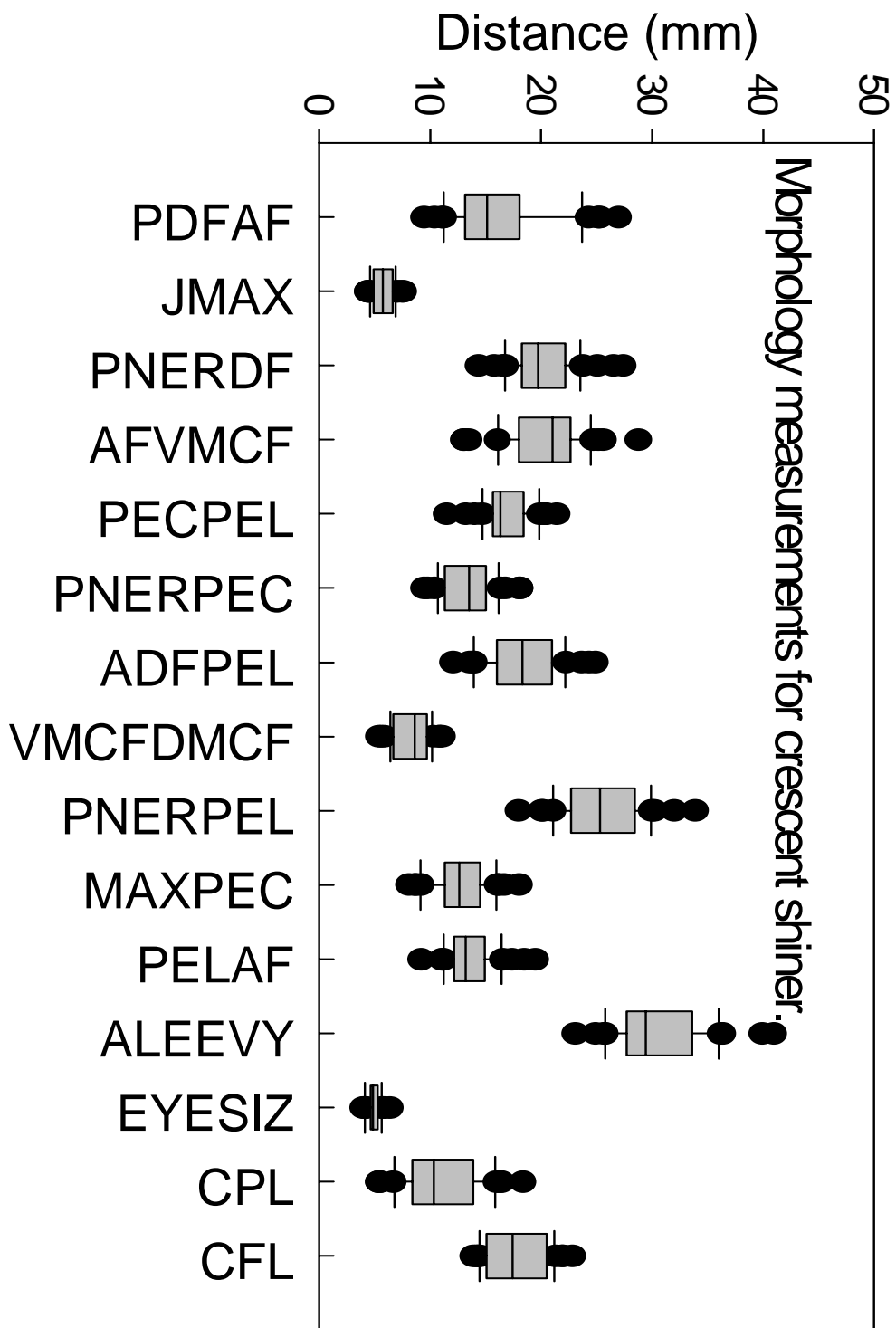

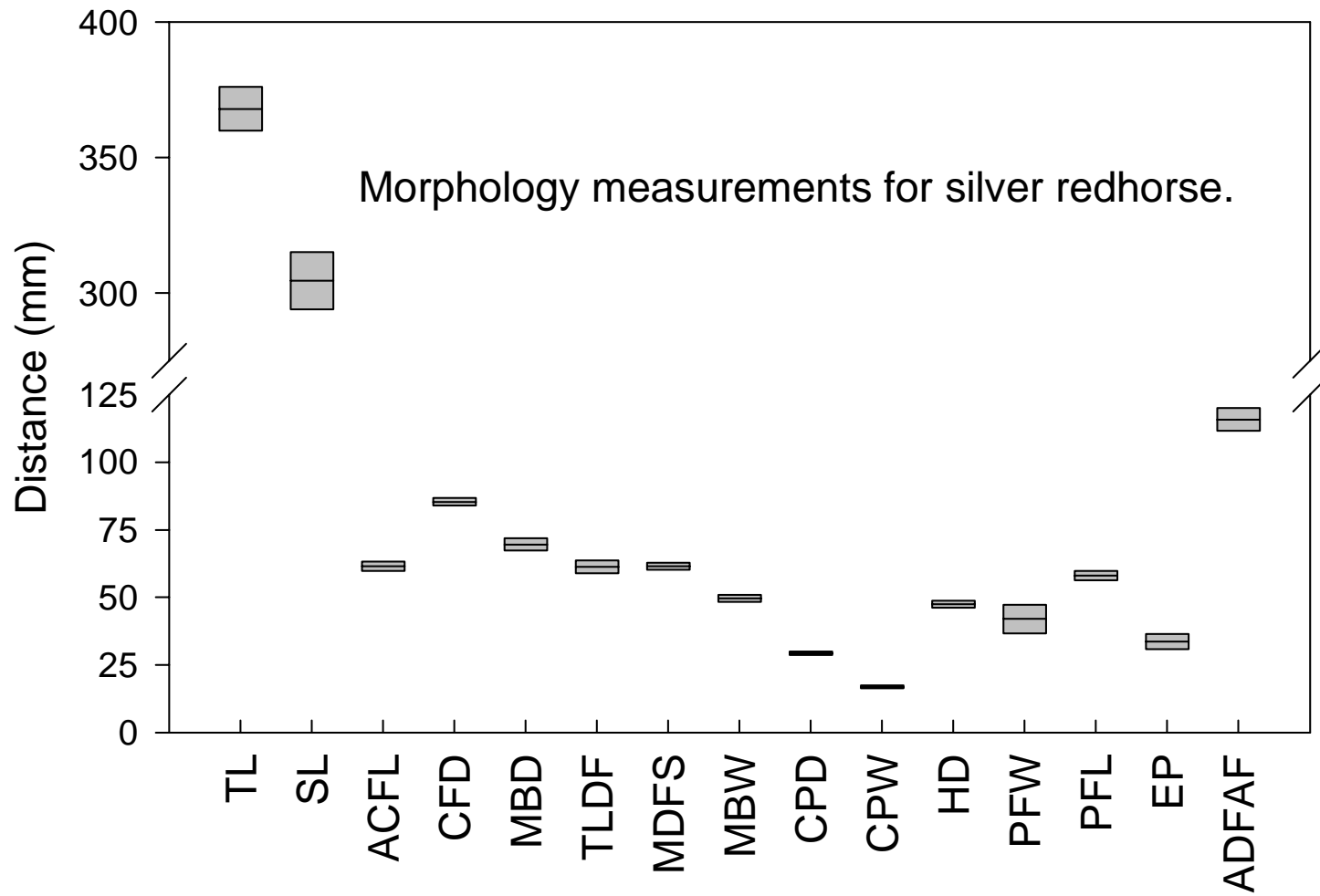

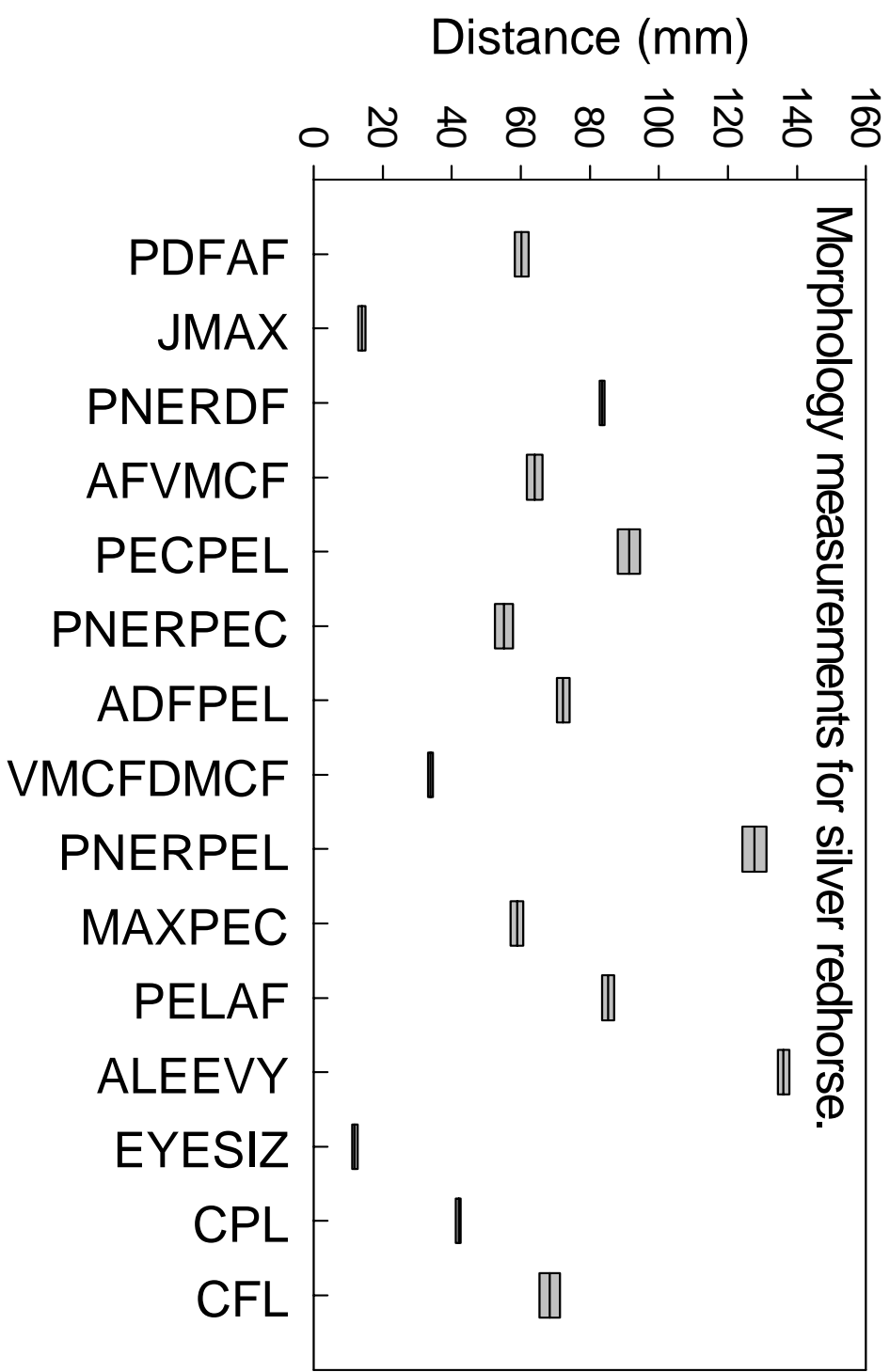

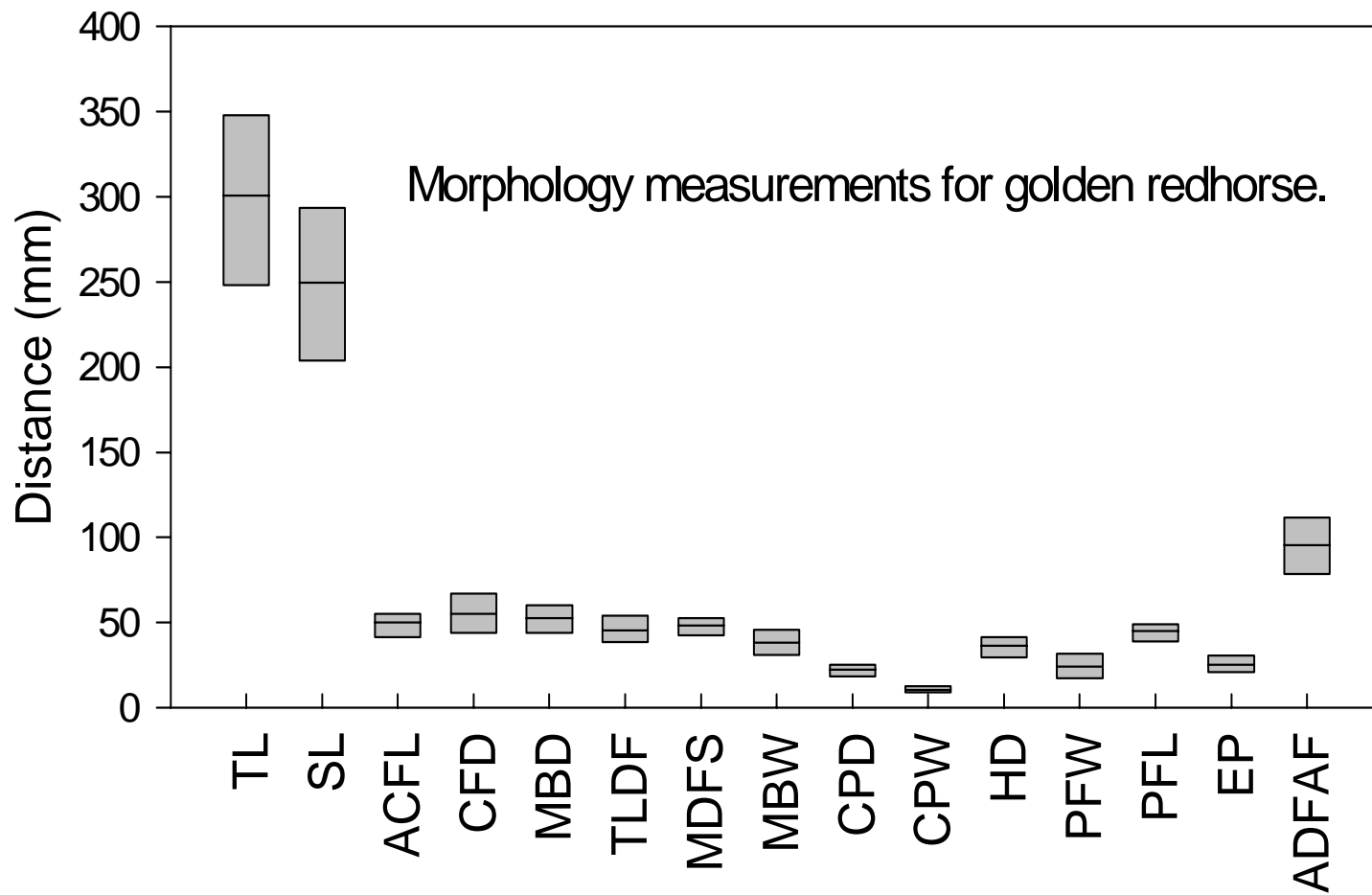

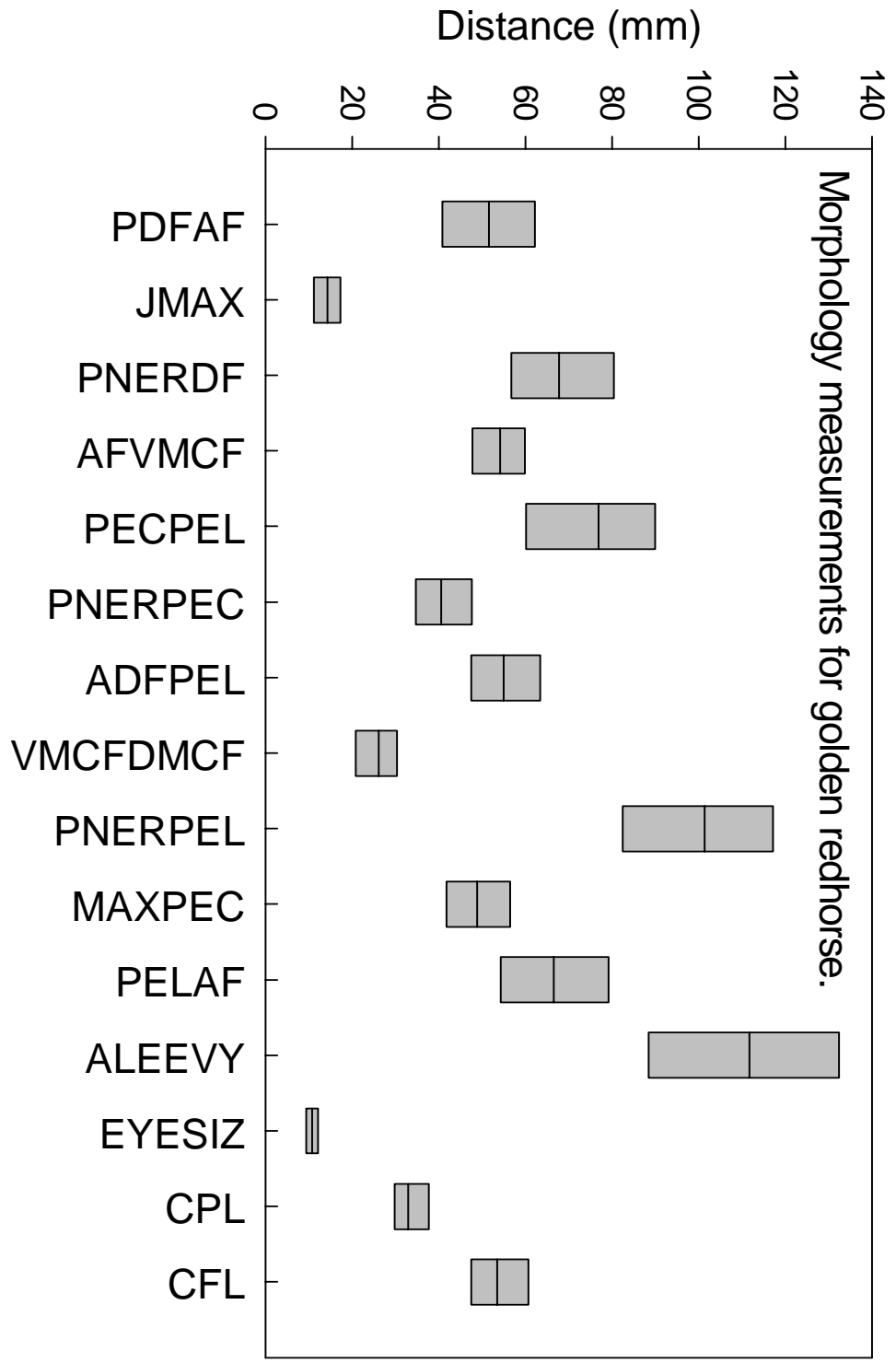

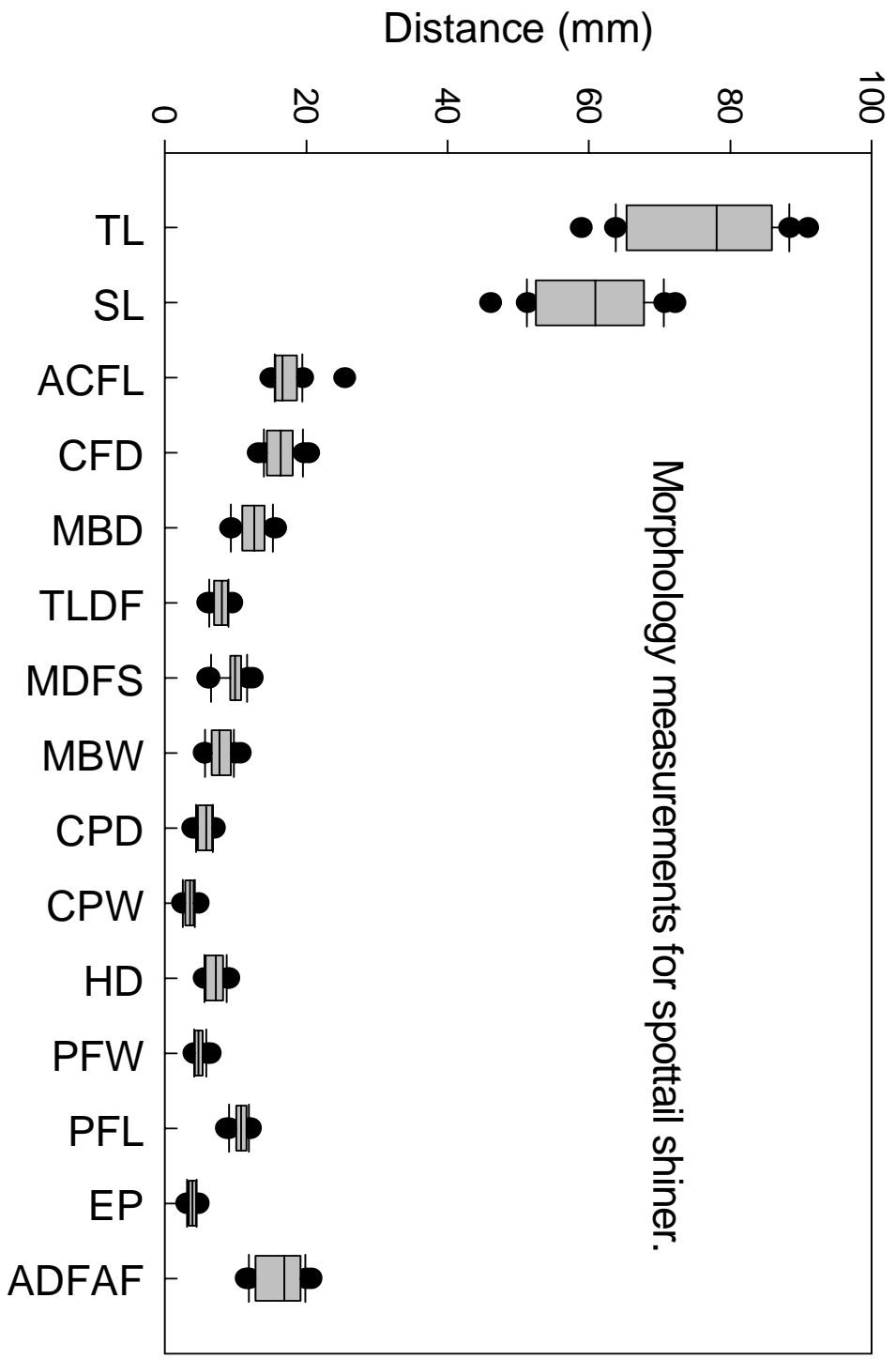

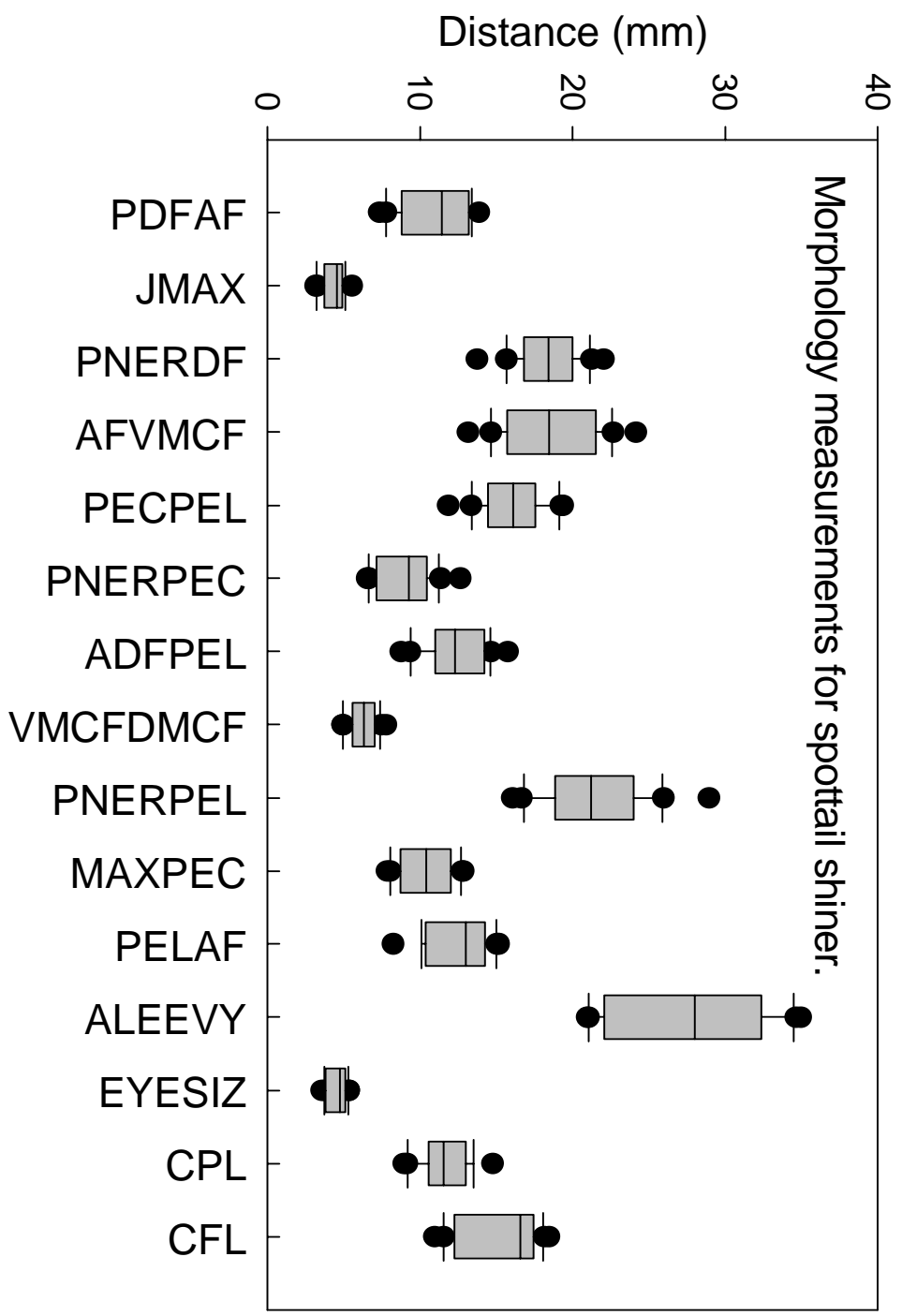

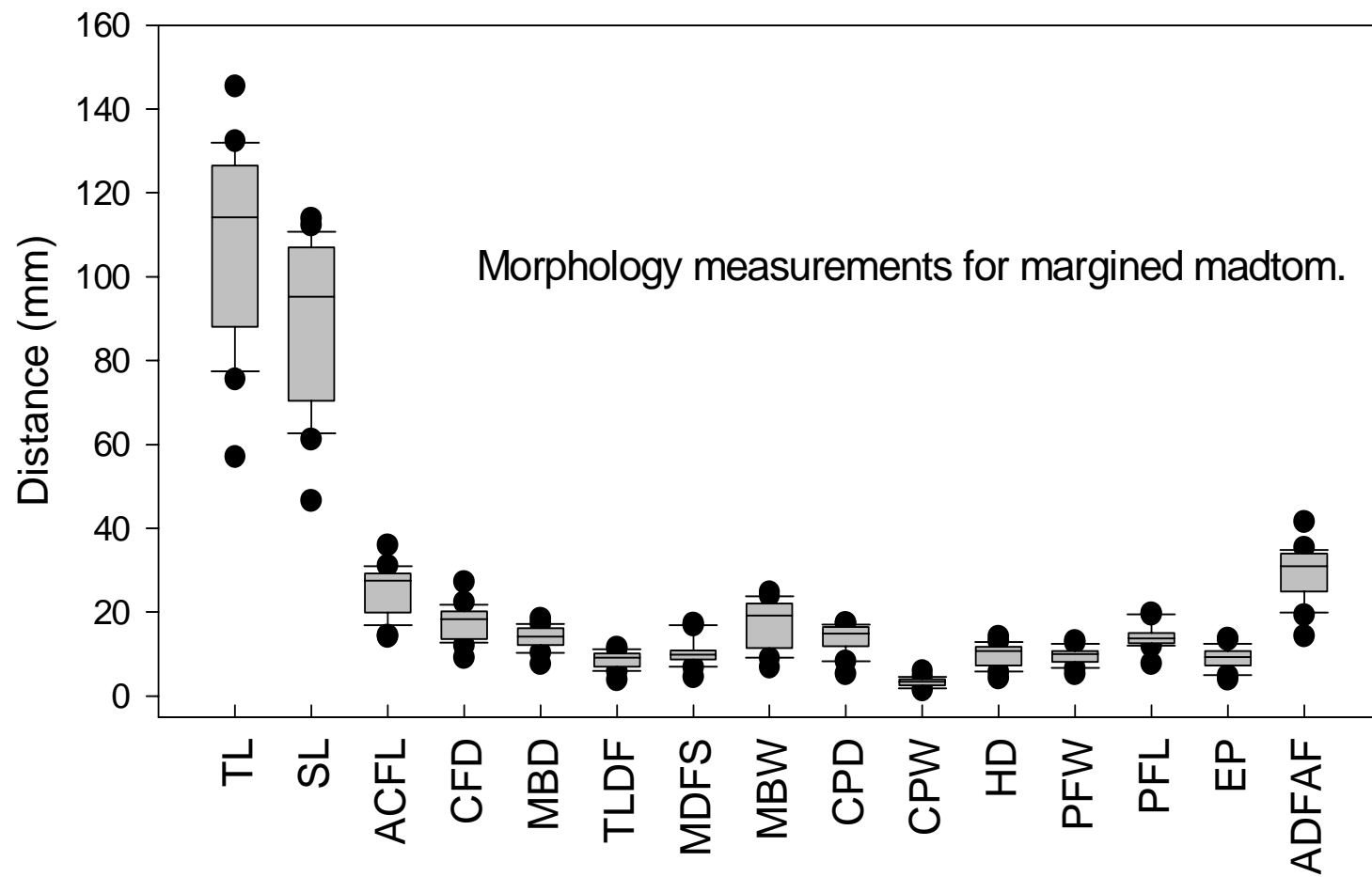

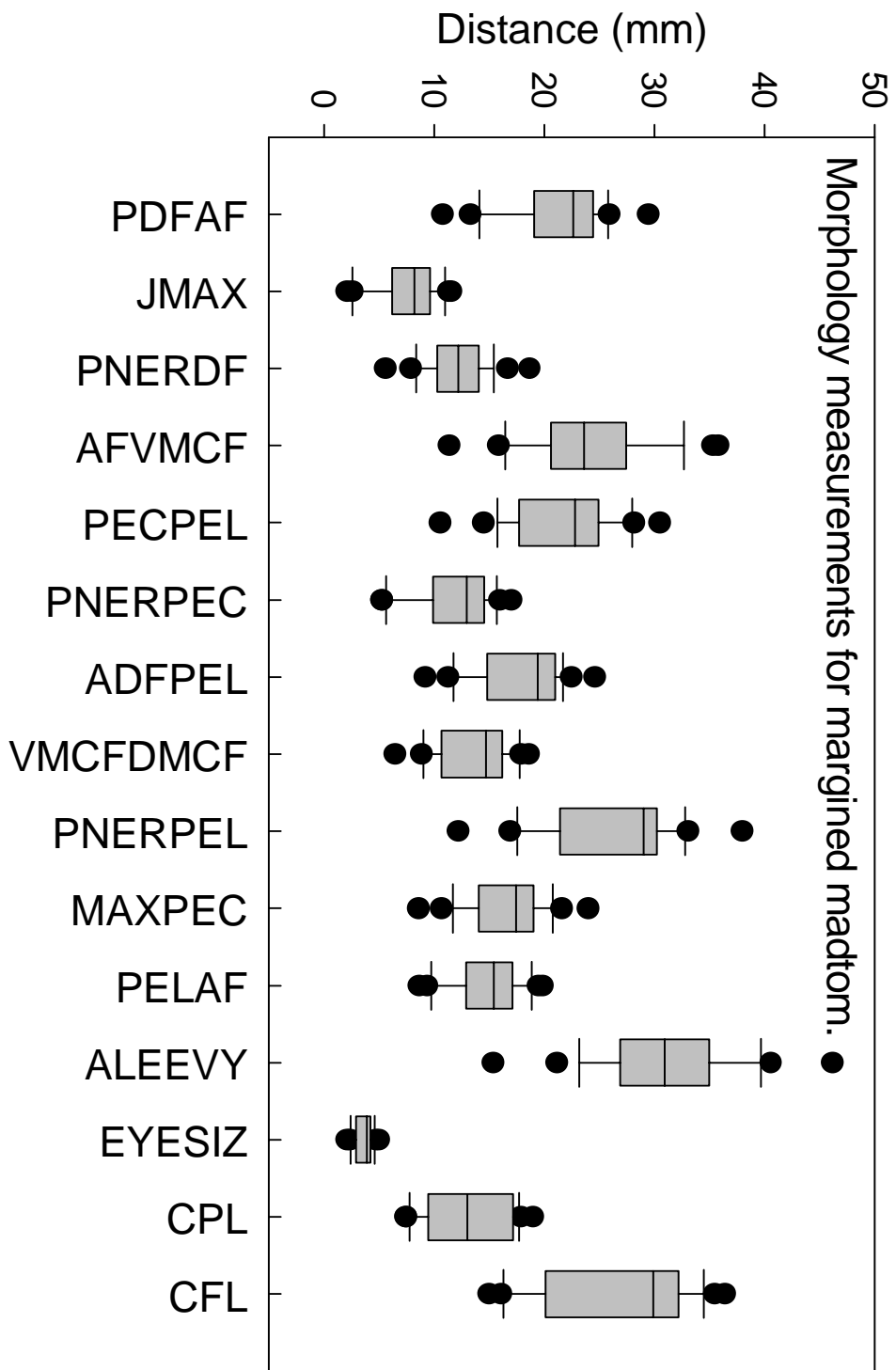

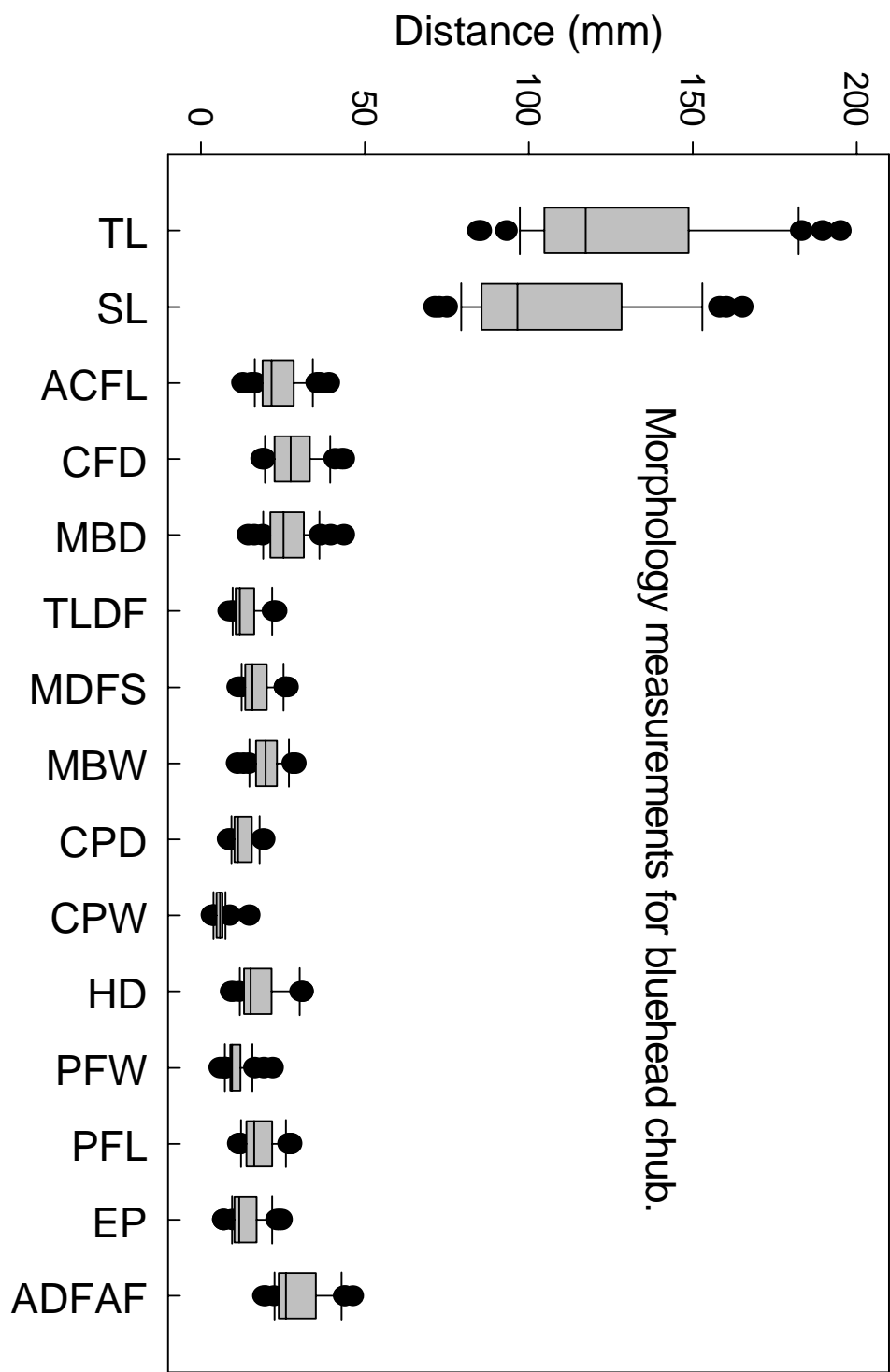

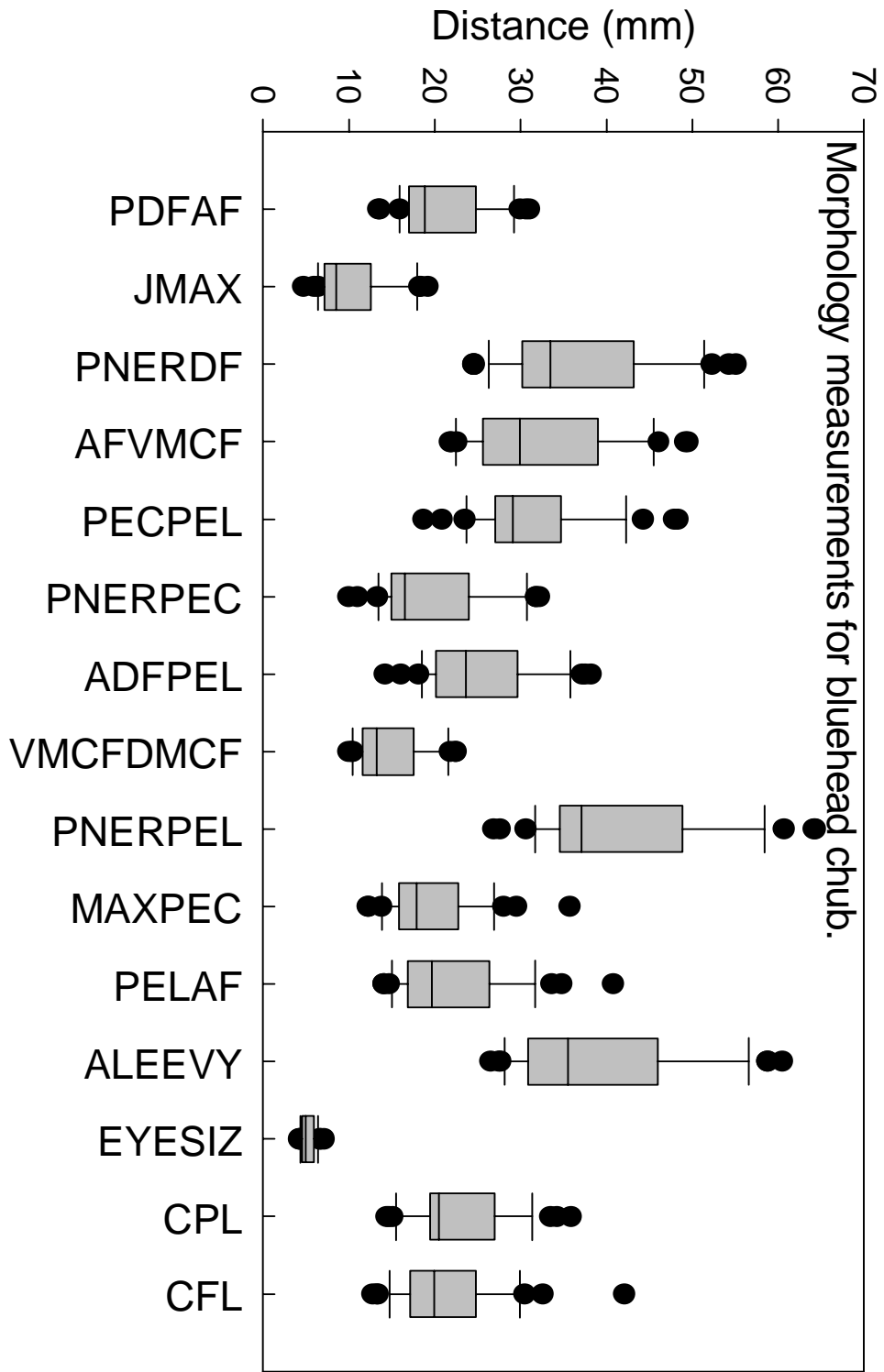

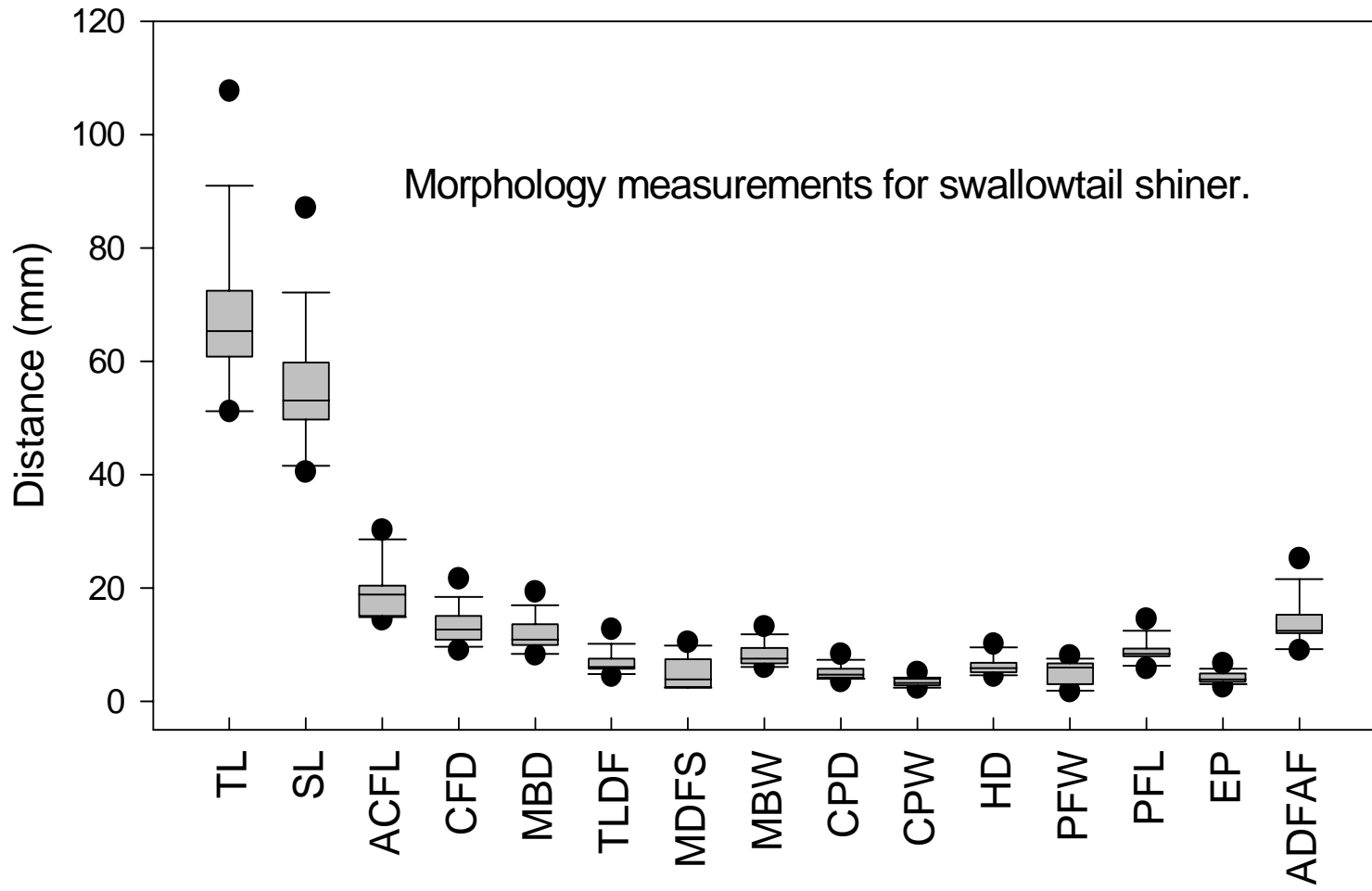

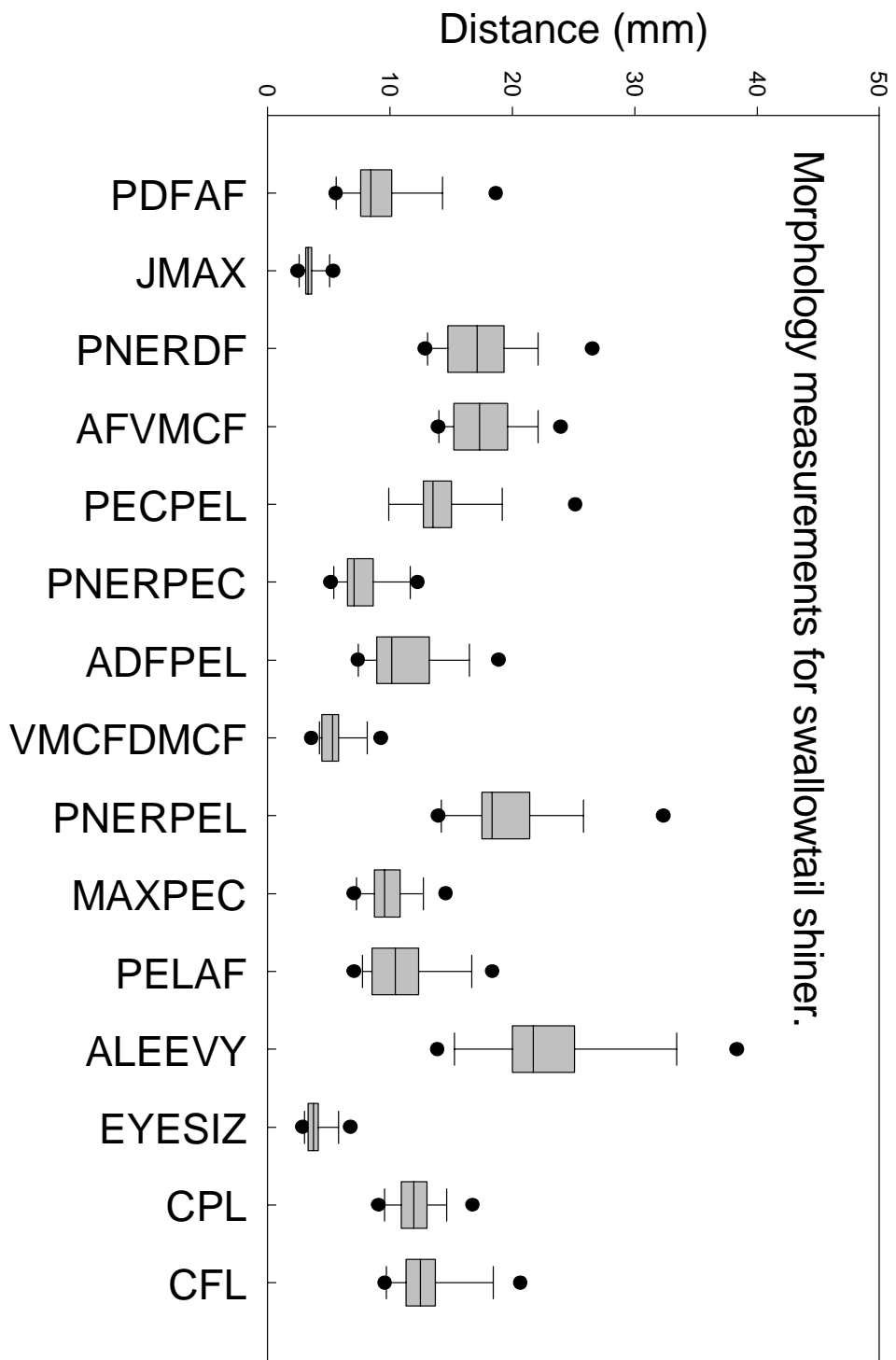

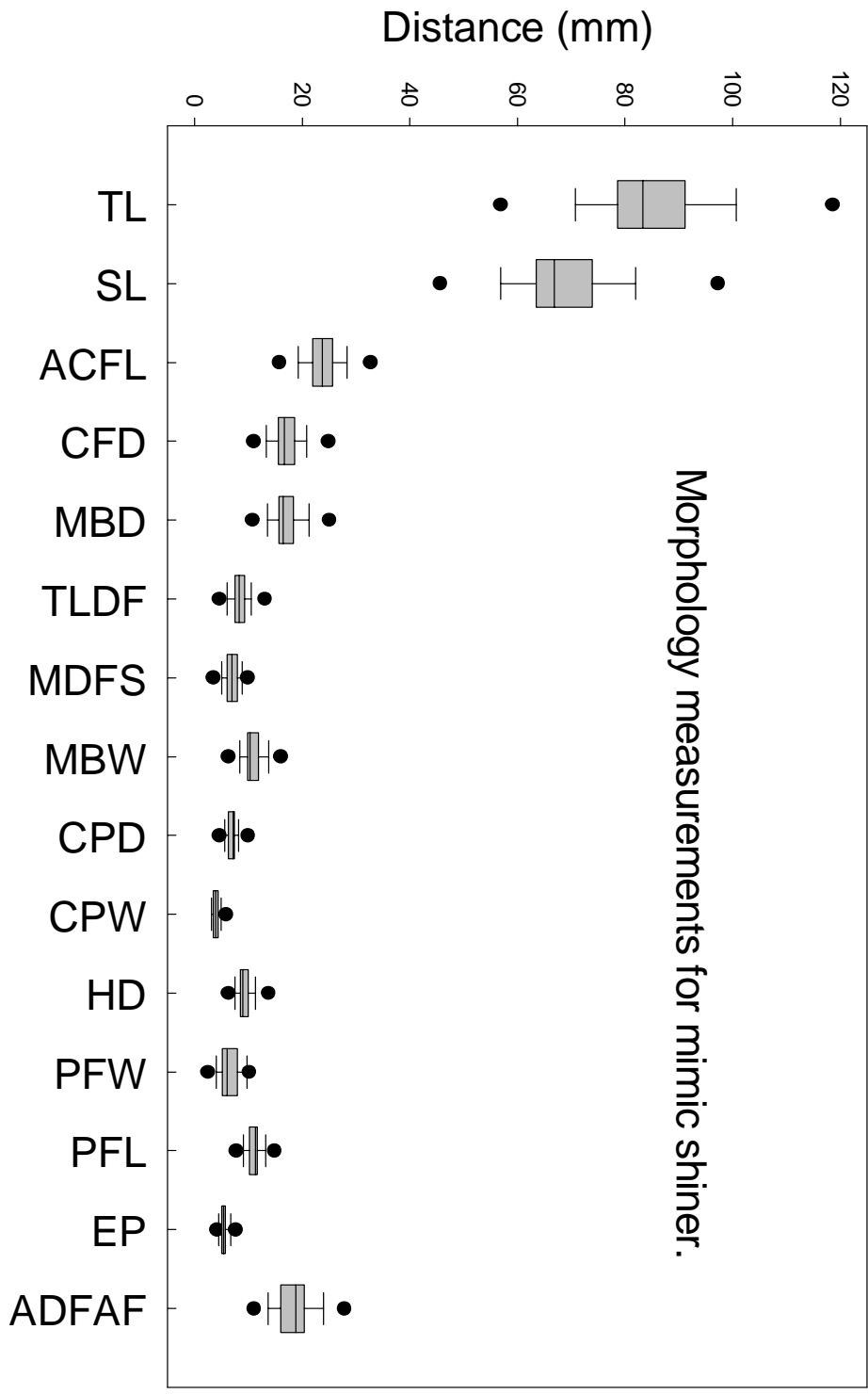

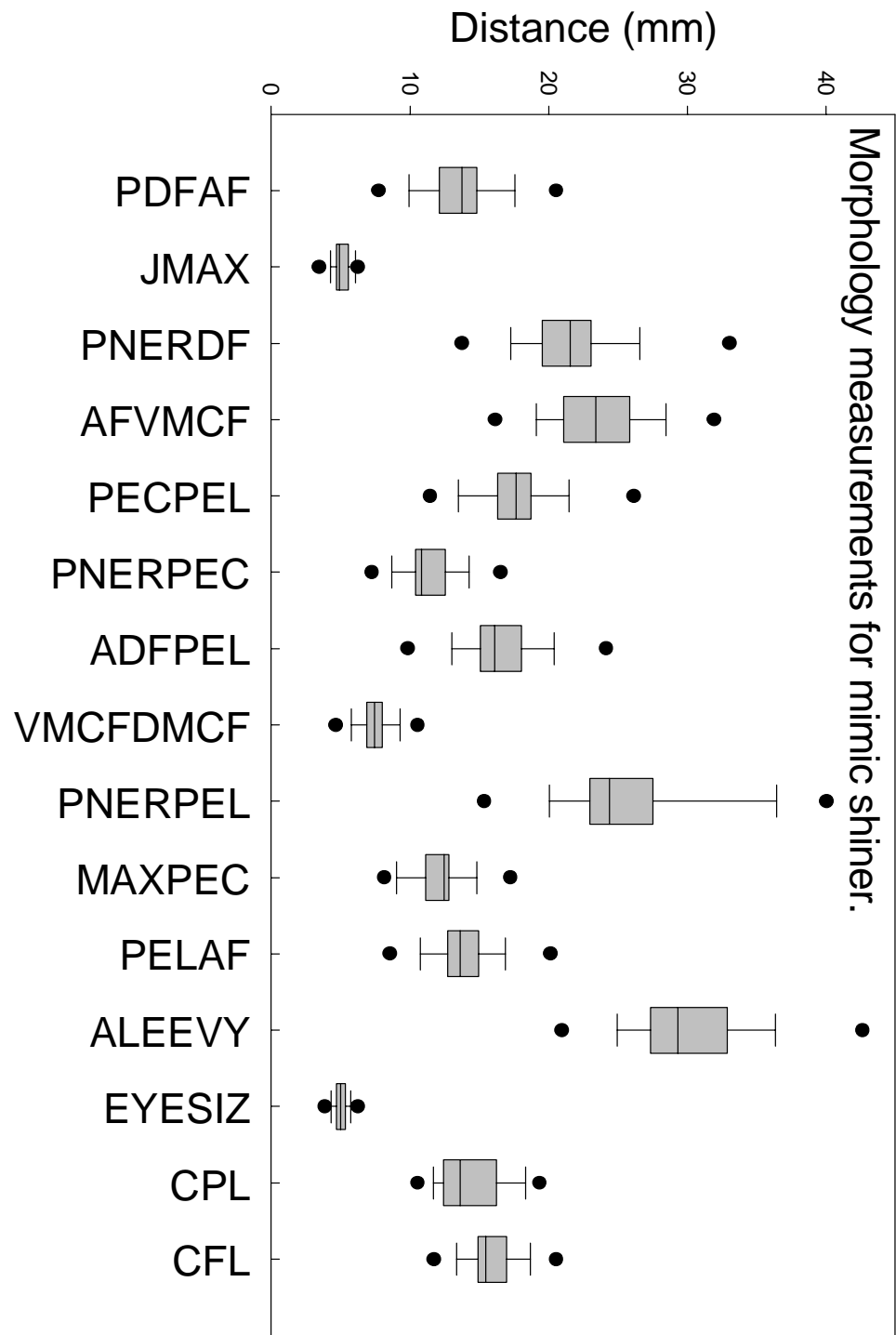

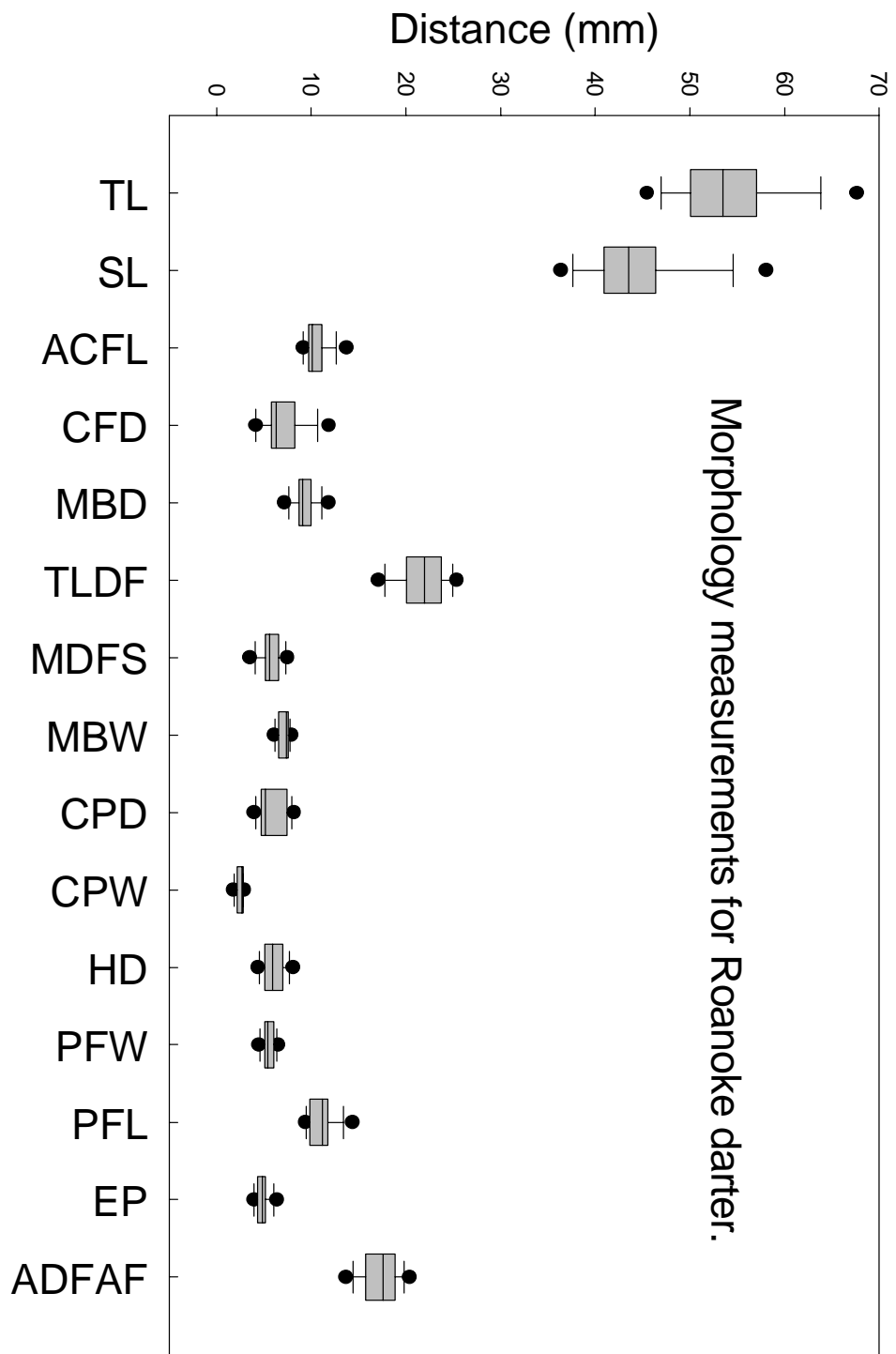

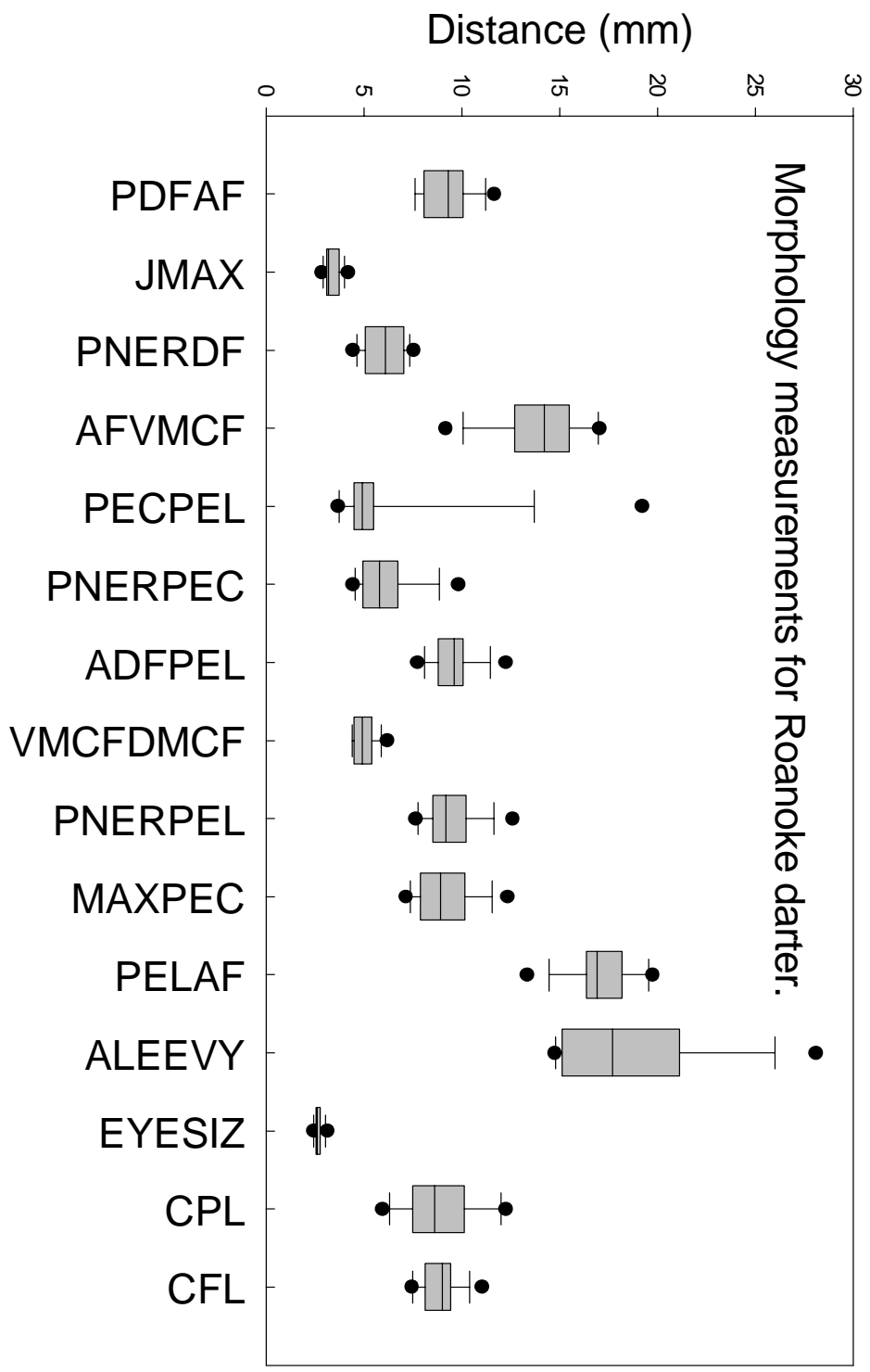

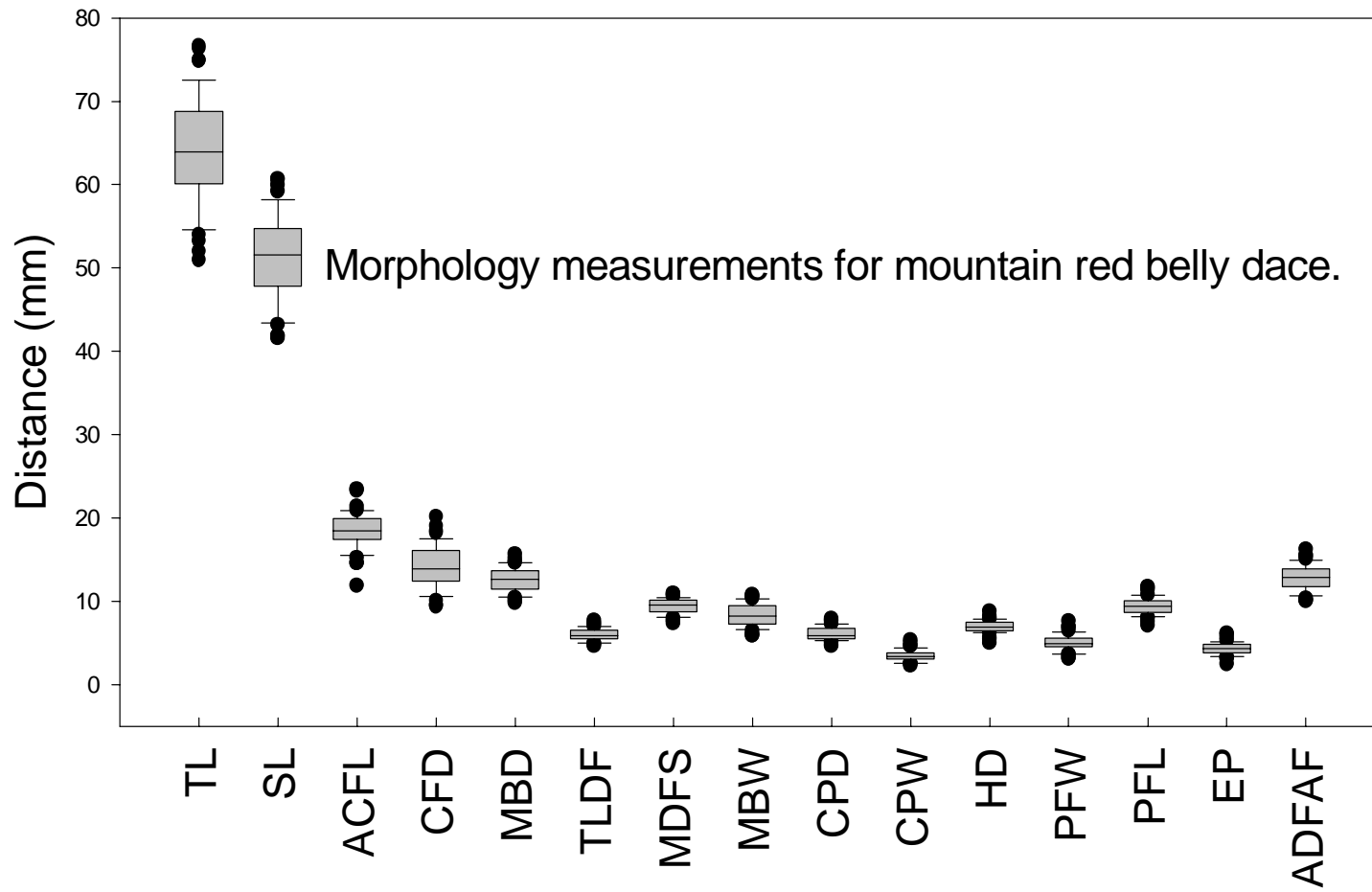

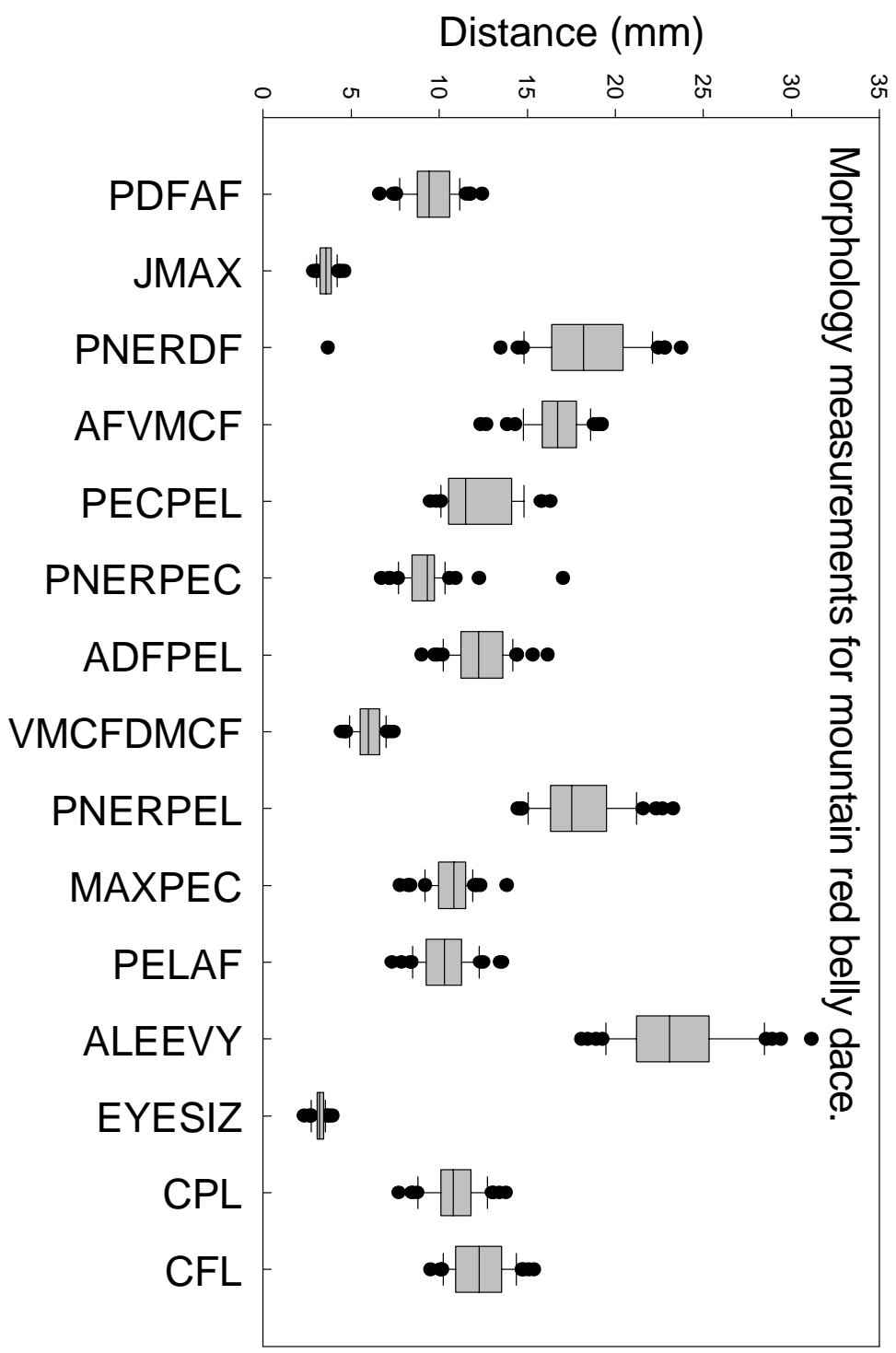

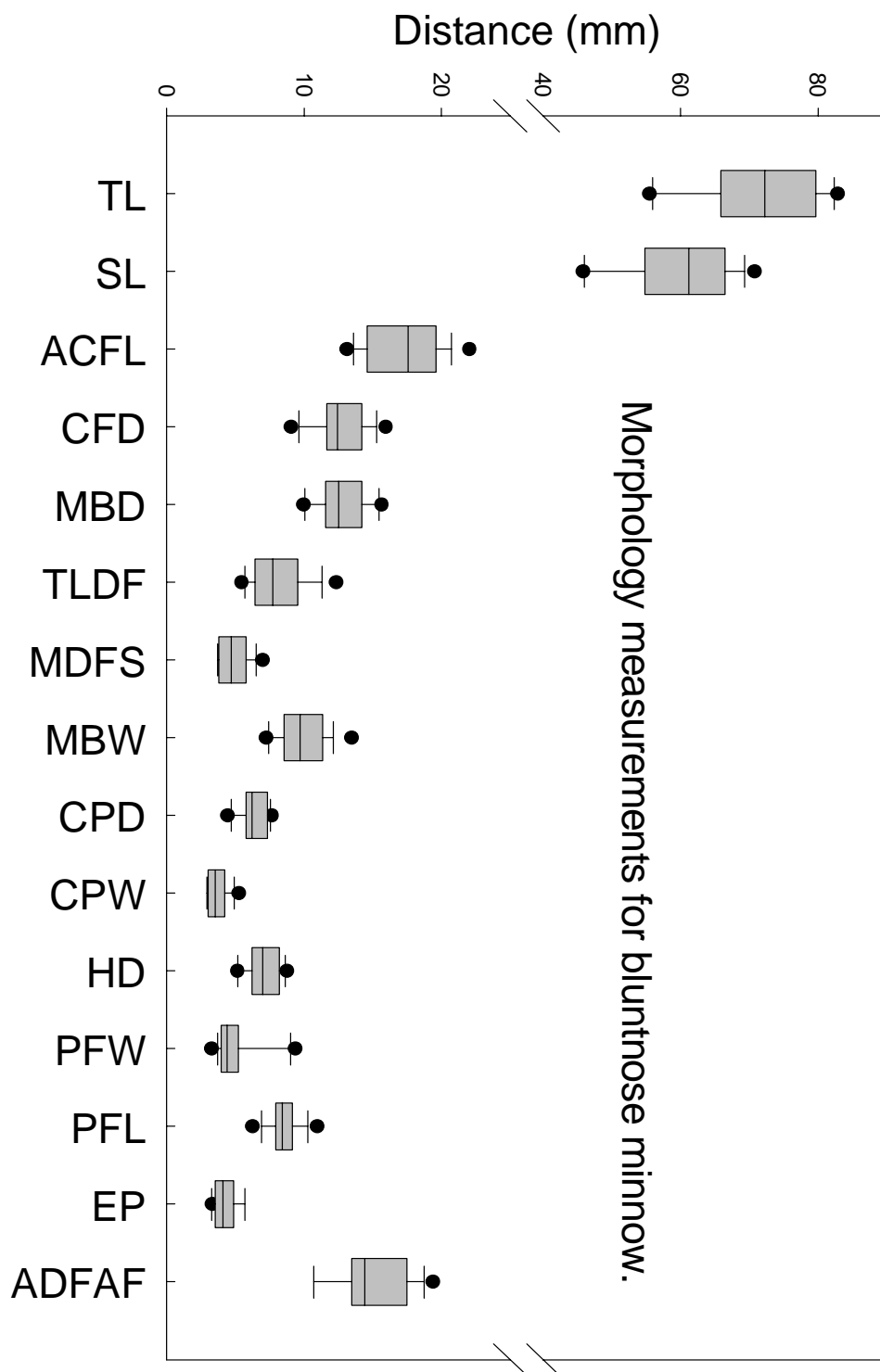

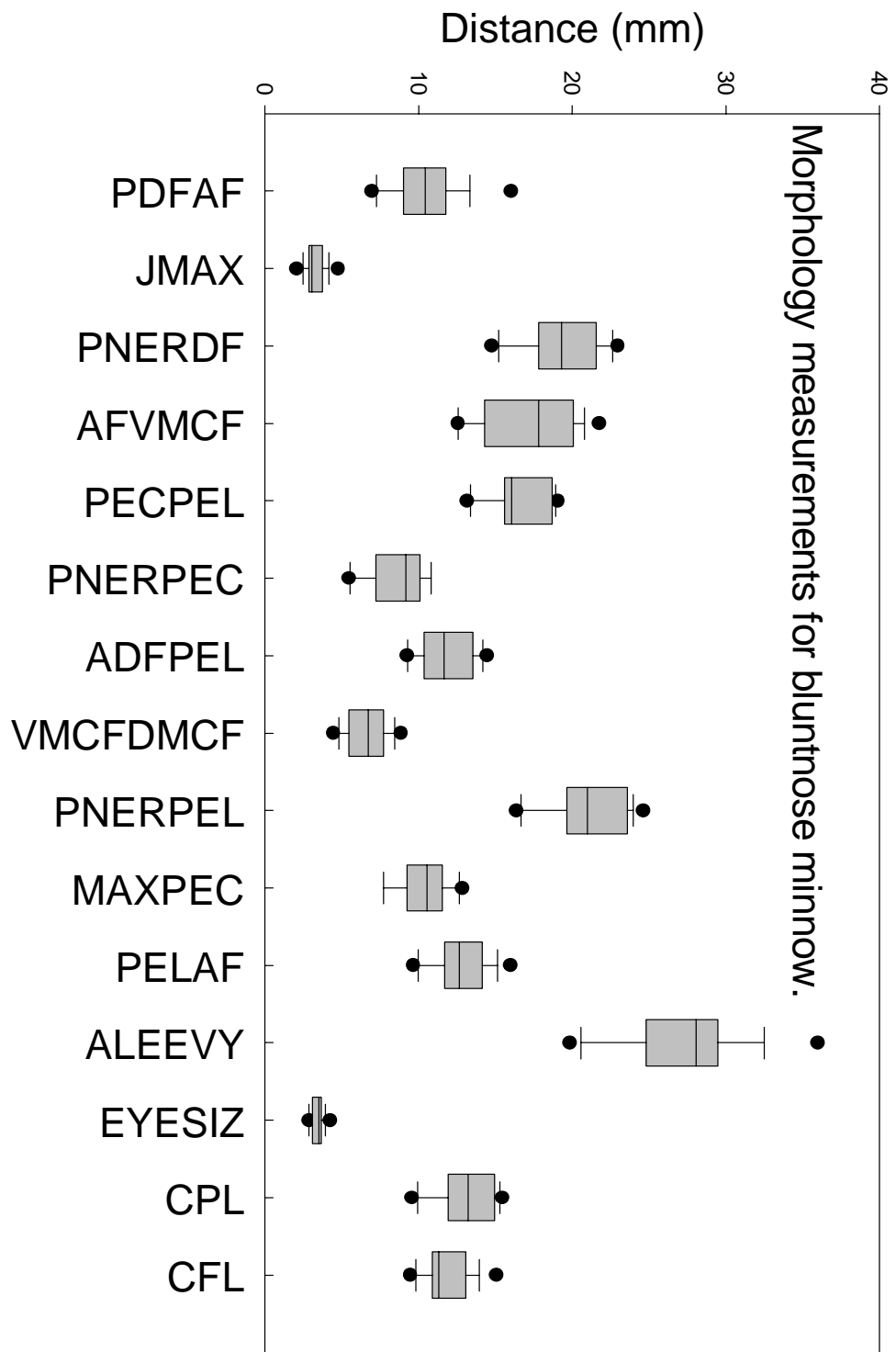

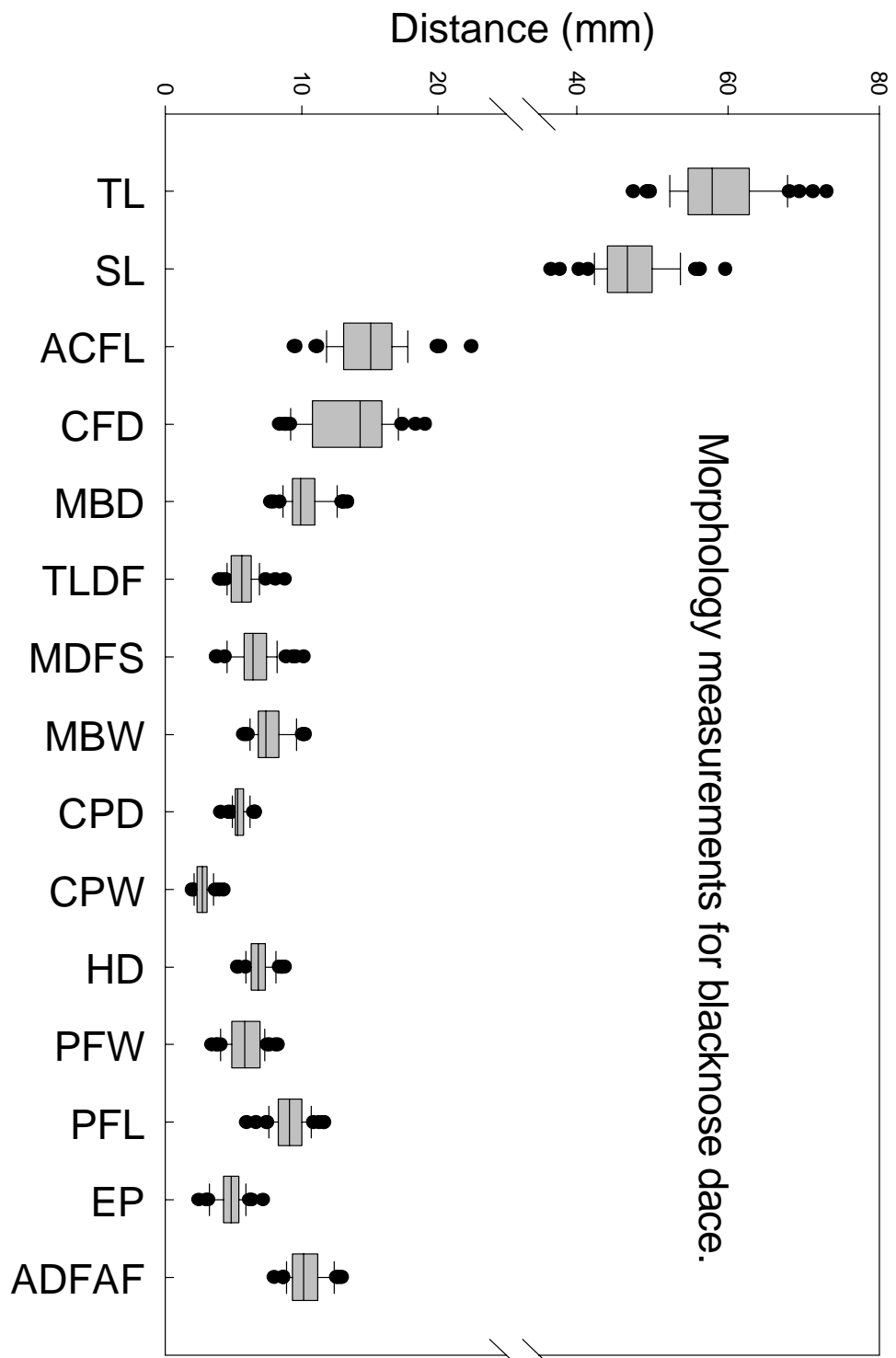

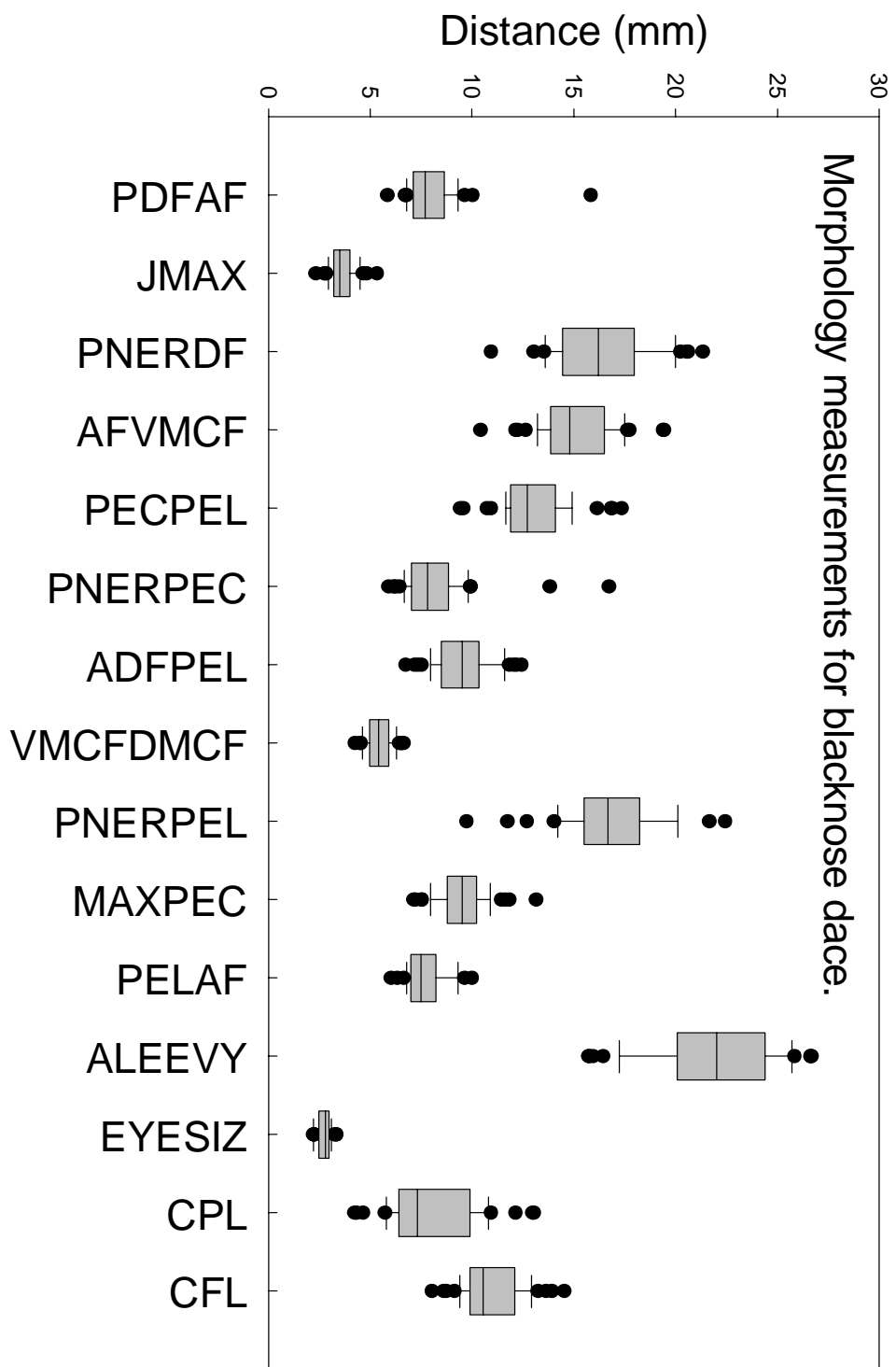

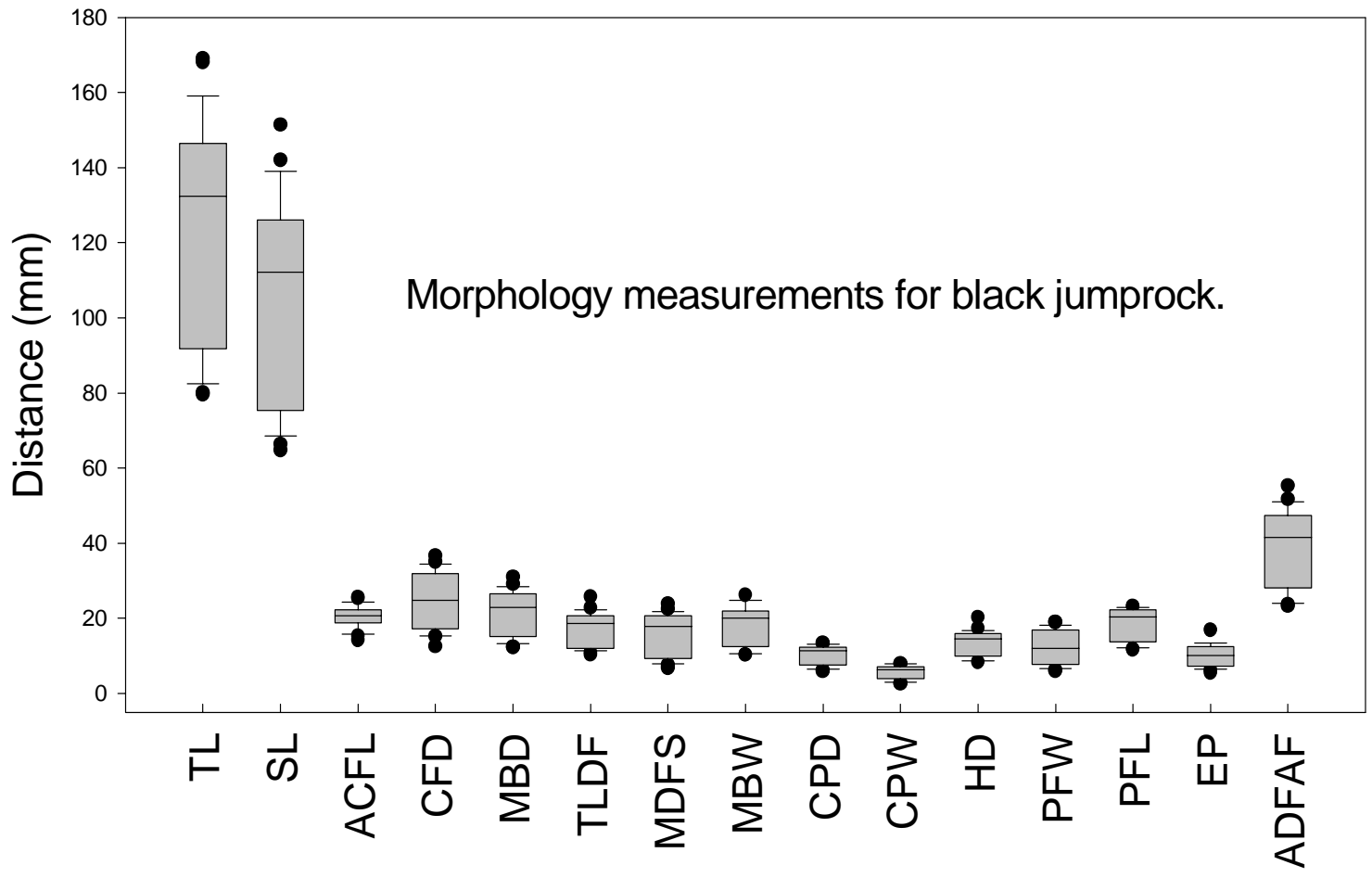

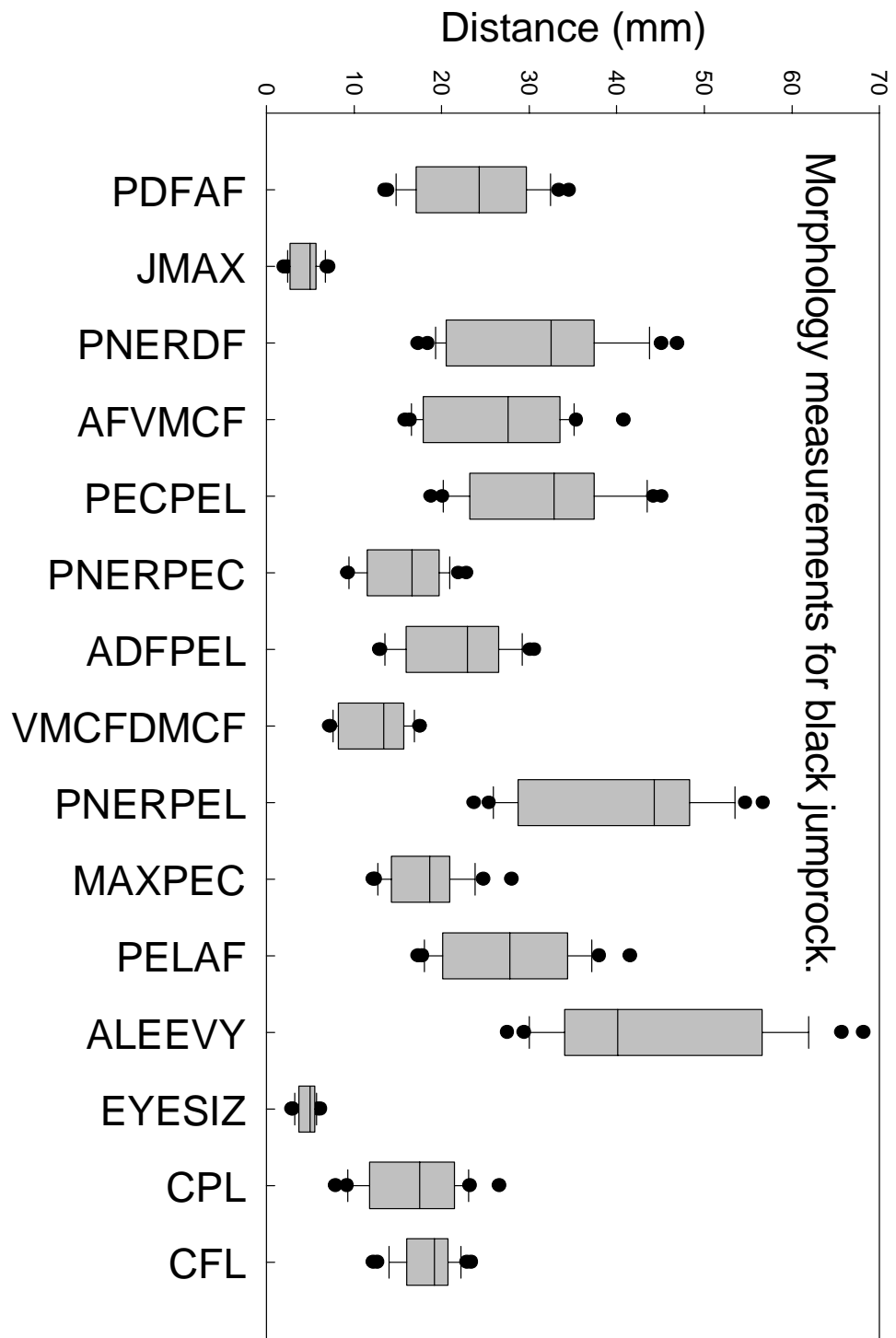

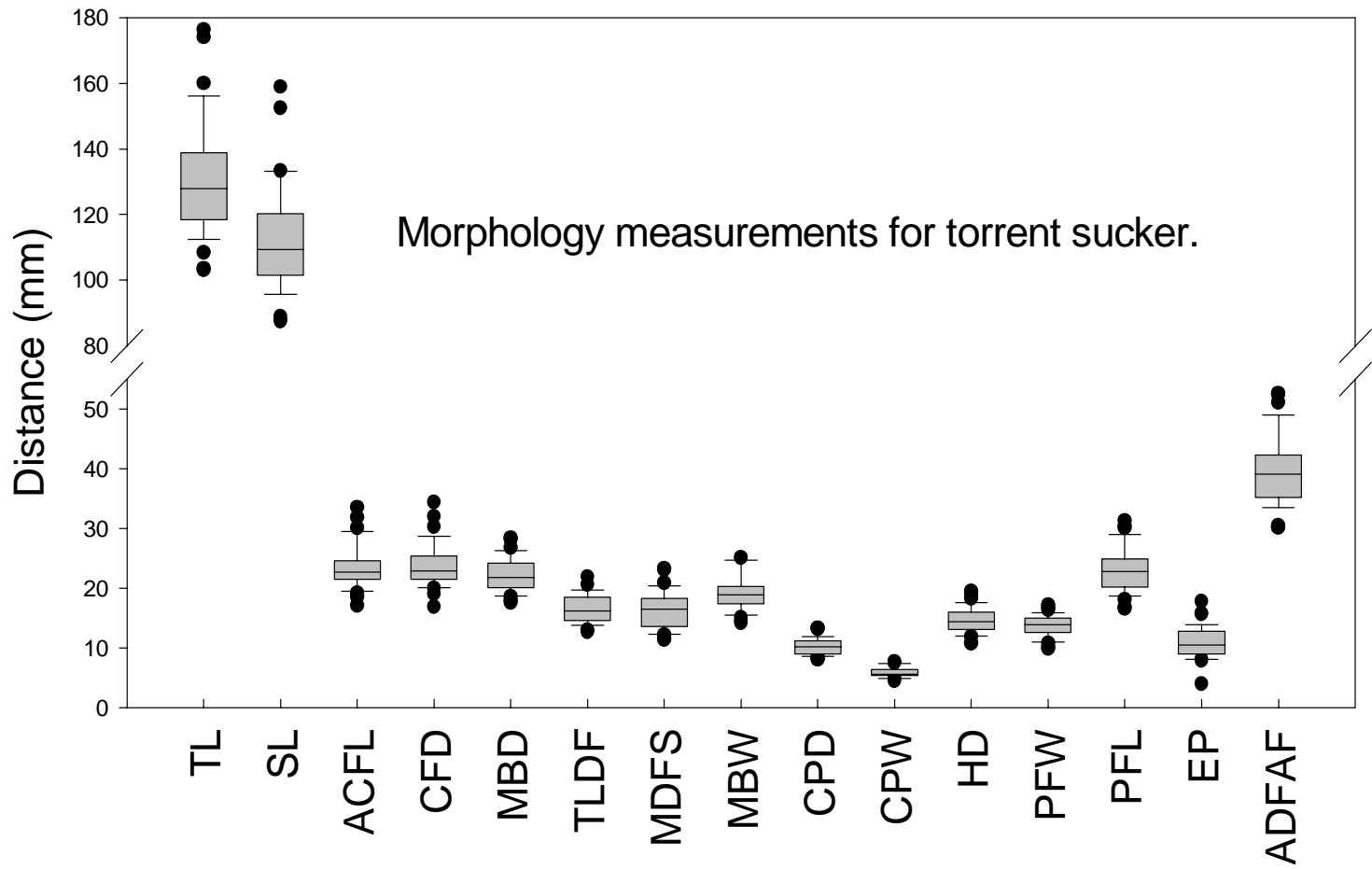

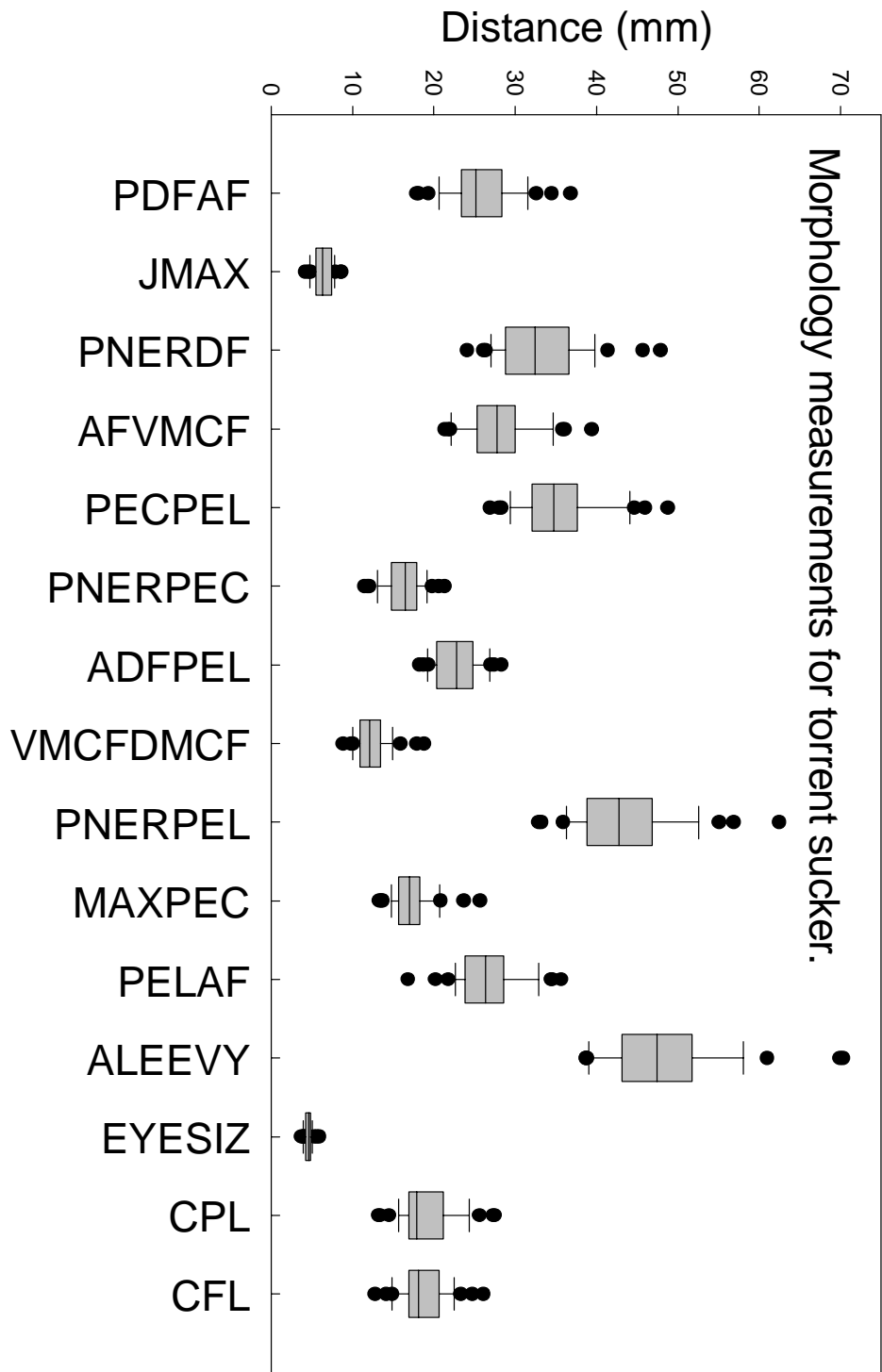

Appendix C. Correlation between morphology measurements

Correlation coefficient matrix for morphology variables taken from fishes of the Roanoke River, Virginia. (n=526). Morphology measurements and their acronyms are total length (TL), standard length (SL), axial caudal fin length (ACFL), caudal fin depth (CFD), maximum body depth (MBD), total length of dorsal fin(s) (TLDF), maximum dorsal fin span (MDFS), maximum body width (MBW), caudal peduncle depth (CPD), caudal peduncle width (CPW), head depth (HD), pectoral fin width (PFW), pectoral fin length (PFL), eye position (EP), distance from dorsal fin to anal fin (ADFAF), distance from posterior of dorsal fin to anal fin (PDFAF), upper jaw length (JMAX), pre-dorsal fin length (PNERDF), distance from anal fin to caudal fin (AFVMCF), distance from pectoral fin to pelvic fin (PECPEL), distance from posterior of neurocranium to pectoral fin (PNERPEC), distance from dorsal fin to pelvic fin (ADFPEL), anterior caudal fin depth (VMCFDMCF), distance from neurocranium to pelvic fin (PNERPEL), distance from jaw to pectoral fin (MAXPEC), distance from pelvic fin to anal fin (PELAF), distance from most anterior point of body to the point of greatest body depth (ALEEVY), eye diameter (EYESIZE), caudal peduncle length (CPL), caudal fin length (CFL), ratio of fin height to body depth (MDFSMBD), streamlining (TRUNK), pectoral fin area (PECAREA), pectoral fin aspect ratio (PECASP), eye vertical position (EYELOC), relative eye size (EYESIZHD), ratio of caudal fin depth to body depth (CFDMBD), body compression (MBDMBW), caudal fin area (CFAREA), caudal fin aspect ratio (CFASP), a second caudal fin aspect ratio (CFASP2), a third caudal fin aspect ratio (CFASP22), and caudal peduncle compression index (CPINDEX). For illustrations of original measurements and instructions on how to derive other measurements see Appendix A.

Table C.1. Matrix of correlation coefficients for morphology measurements taken from fishes of the Roanoke River.

	SL	ACFL	CFD	MBD	TLDF	MDFS
SL	1.00000	-0.52408	-0.33844	-0.35768	-0.23630	-0.08712
ACFL	-0.52408	1.00000	0.18375	0.04015	0.17661	-0.18885
CFD	-0.33844	0.18375	1.00000	0.49954	-0.47221	0.44302
MBD	-0.35768	0.04015	0.49954	1.00000	-0.11017	0.44096
TLDF	-0.23630	0.17661	-0.47221	-0.11017	1.00000	-0.41420
MDFS	-0.08712	-0.18885	0.44302	0.44096	-0.41420	1.00000
MDFSMBD	0.18272	-0.24651	0.13193	-0.16440	-0.36264	0.79543
MBW	0.10766	-0.20007	-0.12776	0.20301	0.12569	-0.05633
CPD	-0.31649	0.30284	-0.00761	0.13988	0.24387	-0.11916
CPW	-0.23202	0.18981	0.26397	0.42087	-0.08665	0.16526
HD	-0.24349	-0.09451	0.32703	0.69324	0.15961	0.28718
TRUNK	-0.23983	0.33950	0.03926	-0.14116	0.25547	-0.16478
PFW	-0.07424	0.05461	-0.13585	-0.09042	0.57050	-0.27366
PFL	-0.35305	0.26217	-0.23578	-0.05075	0.82566	-0.18338
PECAREA	0.23521	-0.38523	-0.11421	-0.01376	0.21807	0.03772
	MDFSMBD	MBW	CPD	CPW	HD	TRUNK
SL	0.18272	0.10766	-0.31649	-0.23202	-0.24349	-0.23983
ACFL	-0.24651	-0.20007	0.30284	0.18981	-0.09451	0.33950
CFD	0.13193	-0.12776	-0.00761	0.26397	0.32703	0.03926
MBD	-0.16440	0.20301	0.13988	0.42087	0.69324	-0.14116
TLDF	-0.36264	0.12569	0.24387	-0.08665	0.15961	0.25547
MDFS	0.79543	-0.05633	-0.11916	0.16526	0.28718	-0.16478
MDFSMBD	1.00000	-0.16603	-0.20279	-0.10982	-0.10892	-0.11354
MBW	-0.16603	1.00000	-0.00058	0.01497	0.37344	-0.44265
CPD	-0.20279	-0.00058	1.00000	0.12631	0.03570	0.03967
CPW	-0.10982	0.01497	0.12631	1.00000	0.18666	0.03002
HD	-0.10892	0.37344	0.03570	0.18666	1.00000	-0.15708
TRUNK	-0.11354	-0.44265	0.03967	0.03002	-0.15708	1.00000
PFW	-0.22744	0.38313	0.04916	-0.11027	0.25185	0.09406
PFL	-0.16354	0.02244	0.11877	-0.08185	0.22195	0.31708
PECAREA	0.09062	0.40206	-0.29731	-0.13994	0.36298	-0.15984
	PFW	PFL	PECAREA	PECASP	EYELOC	PECPEL
SL	-0.07424	-0.35305	0.23521	-0.47460	0.11298	0.33291
ACFL	0.05461	0.26217	-0.38523	0.53587	-0.21220	-0.40508
CFD	-0.13585	-0.23578	-0.11421	-0.09991	-0.38397	0.37326
MBD	-0.09042	-0.05075	-0.01376	-0.07690	-0.17337	0.13421
TLDF	0.57050	0.82566	0.21807	0.36231	0.40760	-0.86214
MDFS	-0.27366	-0.18338	0.03772	-0.14864	-0.13027	0.38599
MDFSMBD	-0.22744	-0.16354	0.09062	-0.14931	0.01450	0.33392
MBW	0.38313	0.02244	0.40206	-0.41854	0.29944	0.12346
CPD	0.04916	0.11877	-0.29731	0.23634	0.22058	-0.45252
CPW	-0.11027	-0.08185	-0.13994	0.07004	-0.29672	0.06513
HD	0.25185	0.22195	0.36298	-0.21527	0.09113	-0.00462
TRUNK	0.09406	0.31708	-0.15984	0.36483	-0.13697	-0.32605
PFW	1.00000	0.59233	0.55226	-0.20441	0.32530	-0.39257
PFL	0.59233	1.00000	0.24779	0.43953	0.33871	-0.71943
PECAREA	0.55226	0.24779	1.00000	-0.59206	0.27618	0.10291

Table C.1 *continued*. Matrix of correlation coefficients for morphology measurements taken from fishes of the Roanoke River.

	EYESIZ	CPL	CFL	EYESIZHD	CFDMBD	MBDMBW
SL	-0.61113	0.02837	-0.66215	-0.41701	-0.06621	-0.43593
ACFL	0.45225	0.13745	0.43961	0.49722	0.17798	0.21145
CFD	0.27334	-0.10792	0.31681	0.03451	0.70643	0.53294
MBD	0.42817	0.08561	0.19905	-0.02746	-0.22550	0.68760
TLDF	0.26342	-0.14186	0.00210	0.14196	-0.42812	-0.16896
MDFS	0.01836	0.15025	0.03920	-0.18585	0.12435	0.41125
MDFSMBD	-0.29348	0.08056	-0.10341	-0.22683	0.28229	-0.02701
MBW	-0.14581	-0.20081	-0.05368	-0.39013	-0.27732	-0.53856
CPD	0.09379	0.09652	0.43432	0.06608	-0.07941	0.10112
CPW	0.19065	0.25733	0.02822	0.06580	-0.05117	0.31542
HD	0.25753	-0.23379	0.10066	-0.39683	-0.15039	0.30838
TRUNK	0.16301	-0.15577	0.04446	0.24351	0.12431	0.19487
PFW	0.04812	-0.41297	-0.04922	-0.14142	-0.06713	-0.35282
PFL	0.32226	-0.20527	0.09811	0.14108	-0.22925	-0.04805
PECAREA	-0.35659	-0.42874	-0.24239	-0.56420	-0.08454	-0.33193
	CFAREA	CFASP	CFASP2	CFASP22	ADFAF	PDFAF
SL	0.05880	-0.15689	0.22409	-0.40414	0.09882	-0.02375
ACFL	-0.32021	0.13232	-0.17934	0.56611	-0.33576	-0.24612
CFD	0.42076	-0.71117	0.71318	0.45370	-0.34214	0.06662
MBD	0.26011	-0.33226	0.27913	0.08692	0.08106	0.46112
TLDF	-0.38985	0.48805	-0.50177	0.04190	0.49848	0.10579
MDFS	0.36902	-0.38519	0.38726	-0.00900	-0.01840	0.14556
MDFSMBD	0.25617	-0.19740	0.23606	-0.10919	-0.01037	-0.07267
MBW	0.13399	0.06725	-0.05524	-0.32749	0.16147	0.25811
CPD	-0.15677	0.35727	-0.29501	0.18356	0.07223	0.21663
CPW	0.03492	-0.24641	0.19120	0.19693	-0.10113	0.06249
HD	0.34072	-0.23147	0.18723	-0.07055	0.25079	0.46511
TRUNK	-0.24219	0.00998	-0.03328	0.37818	0.01325	-0.15624
PFW	-0.15674	0.11329	-0.11045	0.05977	0.29231	0.13696
PFL	-0.35707	0.33351	-0.35235	0.18872	0.39748	0.09842
PECAREA	0.56286	-0.07658	0.07876	-0.55994	0.50416	0.30989
	JMAX	PNERDF	AFVMCF	PECPEL	PNERPEC	ADFPEL
SL	-0.37738	0.05681	-0.45700	0.33291	-0.27080	-0.31059
ACFL	0.14408	-0.10841	0.48082	-0.40508	-0.03991	-0.04071
CFD	0.03737	0.56580	-0.11217	0.37326	0.42279	0.44298
MBD	0.33785	0.38941	0.10517	0.13421	0.72191	0.90078
TLDF	0.41324	-0.82479	0.65125	-0.86214	-0.17179	-0.12489
MDFS	-0.12500	0.47747	-0.23455	0.38599	0.36575	0.43870
MDFSMBD	-0.34446	0.24350	-0.33414	0.33392	-0.06898	-0.08432
MBW	0.46269	-0.11755	0.02463	0.12346	0.25037	0.25161
CPD	0.33993	-0.28538	0.33899	-0.45252	0.09528	0.18180
CPW	0.00853	0.31007	0.09530	0.06513	0.30654	0.32357
HD	0.52136	0.07001	0.13748	-0.00462	0.65815	0.66421
TRUNK	-0.12492	-0.14998	0.20162	-0.32605	-0.21499	-0.22878
PFW	0.34044	-0.49367	0.35069	-0.39257	-0.03488	-0.04665
PFL	0.29431	-0.67848	0.61265	-0.71943	-0.12921	-0.07036
PECAREA	0.10509	-0.21735	-0.17884	0.10291	0.08785	0.08056

Table C.1 *continued*. Matrix of correlation coefficients for morphology measurements taken from fishes of the Roanoke River.

	VMCFDMCF	PNRPEL	MAXPEC	PELAF	CPINDEX
SL	-0.12656	0.19794	-0.41980	-0.10576	-0.01401
ACFL	0.05383	-0.33346	0.33073	0.01615	0.04418
CFD	0.11815	0.50513	0.00322	-0.51271	-0.23584
MBD	0.15611	0.40185	0.13999	-0.20896	-0.29065
TLDF	0.11613	-0.84740	0.31812	0.86899	0.17405
MDFS	-0.00216	0.51363	-0.01315	-0.35719	-0.23218
MDFSMBD	-0.06098	0.30646	-0.10414	-0.24713	-0.03574
MBW	0.00298	0.07372	-0.11298	-0.01239	0.00663
CPD	0.75381	-0.37234	0.36510	0.15681	0.62011
CPW	0.03450	0.19041	0.03292	-0.11099	-0.62029
HD	0.13940	0.18870	0.27468	0.02127	-0.18033
TRUNK	-0.02047	-0.30333	0.31436	0.31743	-0.03797
PFW	0.02519	-0.45773	0.12805	0.43707	0.09459
PFL	0.03430	-0.70056	0.30102	0.69804	0.08885
PECAREA	-0.10933	0.06361	-0.16455	0.21975	-0.10053

	SL	ACFL	CFD	MBD	TLDF	MDFS
PECASP	-0.47460	0.53587	-0.09991	-0.07690	0.36231	-0.14864
EYELOC	0.11298	-0.21220	-0.38397	-0.17337	0.40760	-0.13027
PECPEL	0.33291	-0.40508	0.37326	0.13421	-0.86214	0.38599
EYESIZ	-0.61113	0.45225	0.27334	0.42817	0.26342	0.01836
CPL	0.02837	0.13745	-0.10792	0.08561	-0.14186	0.15025
CFL	-0.66215	0.43961	0.31681	0.19905	0.00210	0.03920
EYESIZHD	-0.41701	0.49722	0.03451	-0.02746	0.14196	-0.18585
CFDMBD	-0.06621	0.17798	0.70643	-0.22550	-0.42812	0.12435
MBDMBW	-0.43593	0.21145	0.53294	0.68760	-0.16896	0.41125
CFAREA	0.05880	-0.32021	0.42076	0.26011	-0.38985	0.36902
CFASP	-0.15689	0.13232	-0.71117	-0.33226	0.48805	-0.38519
CFASP2	0.22409	-0.17934	0.71318	0.27913	-0.50177	0.38726
CFASP22	-0.40414	0.56611	0.45370	0.08692	0.04190	-0.00900
ADFAF	0.09882	-0.33576	-0.34214	0.08106	0.49848	-0.01840
PDFAF	-0.02375	-0.24612	0.06662	0.46112	0.10579	0.14556

	MDFSMBD	MBW	CPD	CPW	HD	TRUNK
PECASP	-0.14931	-0.41854	0.23634	0.07004	-0.21527	0.36483
EYELOC	0.01450	0.29944	0.22058	-0.29672	0.09113	-0.13697
PECPEL	0.33392	0.12346	-0.45252	0.06513	-0.00462	-0.32605
EYESIZ	-0.29348	-0.14581	0.09379	0.19065	0.25753	0.16301
CPL	0.08056	-0.20081	0.09652	0.25733	-0.23379	-0.15577
CFL	-0.10341	-0.05368	0.43432	0.02822	0.10066	0.04446
EYESIZHD	-0.22683	-0.39013	0.06608	0.06580	-0.39683	0.24351
CFDMBD	0.28229	-0.27732	-0.07941	-0.05117	-0.15039	0.12431
MBDMBW	-0.02701	-0.53856	0.10112	0.31542	0.30838	0.19487
CFAREA	0.25617	0.13399	-0.15677	0.03492	0.34072	-0.24219
CFASP	-0.19740	0.06725	0.35727	-0.24641	-0.23147	0.00998
CFASP2	0.23606	-0.05524	-0.29501	0.19120	0.18723	-0.03328
CFASP22	-0.10919	-0.32749	0.18356	0.19693	-0.07055	0.37818
ADFAF	-0.01037	0.16147	0.07223	-0.10113	0.25079	0.01325
PDFAF	-0.07267	0.25811	0.21663	0.06249	0.46511	-0.15624

Table C.1 *continued*. Matrix of correlation coefficients for morphology measurements taken from fishes of the Roanoke River.

	PFW	PFL	PECAREA	PECASP	EYELOC	PECPEL
PECASP	-0.20441	0.43953	-0.59206	1.00000	-0.06080	-0.55713
EYELOC	0.32530	0.33871	0.27618	-0.06080	1.00000	-0.27004
PECPEL	-0.39257	-0.71943	0.10291	-0.55713	-0.27004	1.00000
EYESIZ	0.04812	0.32226	-0.35659	0.51622	-0.21581	-0.38792
CPL	-0.41297	-0.20527	-0.42874	0.30197	-0.19914	-0.03709
CFL	-0.04922	0.09811	-0.24239	0.27065	-0.07094	-0.19297
EYESIZHD	-0.14142	0.14108	-0.56420	0.62541	-0.27008	-0.35892
CFDMBD	-0.06713	-0.22925	-0.08454	-0.08890	-0.25651	0.30419
MBDMBW	-0.35282	-0.04805	-0.33193	0.27410	-0.38557	-0.00391
CFAREA	-0.15674	-0.35707	0.56286	-0.59989	-0.10278	0.50604
CFASP	0.11329	0.33351	-0.07658	0.32122	0.33388	-0.53085
CFASP2	-0.11045	-0.35235	0.07876	-0.35029	-0.28859	0.53557
CFASP22	0.05977	0.18872	-0.55994	0.60416	-0.24549	-0.24700
ADFAF	0.29231	0.39748	0.50416	-0.17411	0.39790	-0.29156
PDFAF	0.13696	0.09842	0.30989	-0.30958	0.23319	-0.00992
	EYESIZ	CPL	CFL	EYESIZHD	CFDMBD	MBDMBW
PECASP	0.51622	0.30197	0.27065	0.62541	-0.08890	0.27410
EYELOC	-0.21581	-0.19914	-0.07094	-0.27008	-0.25651	-0.38557
PECPEL	-0.38792	-0.03709	-0.19297	-0.35892	0.30419	-0.00391
EYESIZ	1.00000	0.02707	0.44295	0.76898	-0.05641	0.54670
CPL	0.02707	1.00000	-0.15050	0.20851	-0.21825	0.19616
CFL	0.44295	-0.15050	1.00000	0.34965	0.21564	0.27435
EYESIZHD	0.76898	0.20851	0.34965	1.00000	0.03008	0.33097
CFDMBD	-0.05641	-0.21825	0.21564	0.03008	1.00000	0.02728
MBDMBW	0.54670	0.19616	0.27435	0.33097	0.02728	1.00000
CFAREA	-0.29521	-0.24985	0.14505	-0.47768	0.29011	0.10825
CFASP	0.05240	0.00111	0.38282	0.20851	-0.52125	-0.29668
CFASP2	-0.13225	-0.01394	-0.40793	-0.25608	0.56369	0.24308
CFASP22	0.48078	0.13559	0.13409	0.47706	0.40498	0.33122
ADFAF	-0.14869	-0.26208	-0.11938	-0.30521	-0.40082	-0.09210
PDFAF	-0.01262	-0.24869	0.10172	-0.31836	-0.22412	0.18012
	CFAREA	CFASP	CFASP2	CFASP22	ADFAF	PDFAF
PECASP	-0.59989	0.32122	-0.35029	0.60416	-0.17411	-0.30958
EYELOC	-0.10278	0.33388	-0.28859	-0.24549	0.39790	0.23319
PECPEL	0.50604	-0.53085	0.53557	-0.24700	-0.29156	-0.00992
EYESIZ	-0.29521	0.05240	-0.13225	0.48078	-0.14869	-0.01262
CPL	-0.24985	0.00111	-0.01394	0.13559	-0.26208	-0.24869
CFL	0.14505	0.38282	-0.40793	0.13409	-0.11938	0.10172
EYESIZHD	-0.47768	0.20851	-0.25608	0.47706	-0.30521	-0.31836
CFDMBD	0.29011	-0.52125	0.56369	0.40498	-0.40082	-0.22412
MBDMBW	0.10825	-0.29668	0.24308	0.33122	-0.09210	0.18012
CFAREA	1.00000	-0.31751	0.32391	-0.49822	0.17782	0.29418
CFASP	-0.31751	1.00000	-0.93979	-0.30518	0.25476	0.00716
CFASP2	0.32391	-0.93979	1.00000	0.27796	-0.23311	0.01457
CFASP22	-0.49822	-0.30518	0.27796	1.00000	-0.48093	-0.34376
ADFAF	0.17782	0.25476	-0.23311	-0.48093	1.00000	0.64707
PDFAF	0.29418	0.00716	0.01457	-0.34376	0.64707	1.00000

Table C.1 *continued*. Matrix of correlation coefficients for morphology measurements taken from fishes of the Roanoke River.

	JMAX	PNERDF	AFVMCF	PECPEL	PNERPEC	ADFPEL
PECASP	0.02278	-0.24564	0.51971	-0.55713	-0.20125	-0.19355
EYELOC	0.21997	-0.52038	0.16506	-0.27004	-0.16205	-0.09656
PECPEL	-0.34862	0.76315	-0.72128	1.00000	0.19162	0.15711
EYESIZ	0.34642	-0.06357	0.51889	-0.38792	0.23702	0.35655
CPL	-0.17771	0.19719	0.16172	-0.03709	-0.01857	-0.03419
CFL	0.33024	-0.12085	0.19408	-0.19297	0.18007	0.26441
EYESIZHD	0.00154	-0.08879	0.39942	-0.35892	-0.20232	-0.08316
CFDMBD	-0.19689	0.30062	-0.21119	0.30419	-0.08850	-0.18209
MBDMBW	0.02792	0.38335	0.10923	-0.00391	0.44138	0.56863
CFAREA	-0.02086	0.31303	-0.50711	0.50604	0.34713	0.34594
CFASP	0.20711	-0.64485	0.26337	-0.53085	-0.28976	-0.23516
CFASP2	-0.22171	0.61854	-0.29909	0.53557	0.22816	0.20227
CFASP22	0.01023	0.13963	0.40080	-0.24700	-0.00705	-0.05894
ADFAF	0.01849	-0.52020	-0.08325	-0.29156	0.00576	0.20275
PDFAF	0.21050	-0.13994	-0.11301	-0.00992	0.35559	0.58583
	VMCFDMCF	PNERPEL	MAXPEC	PELAF	CPINDEX	
PECASP	-0.01954	-0.50814	0.35209	0.30287	0.06044	
EYELOC	0.24528	-0.35877	0.18689	0.36847	0.41173	
PECPEL	-0.25561	0.91217	-0.41053	-0.74789	-0.31923	
EYESIZ	-0.06783	-0.20711	0.26248	0.09554	-0.14597	
CPL	0.03424	0.01304	-0.09603	-0.12139	-0.15547	
CFL	0.26864	-0.10199	0.26949	-0.14991	0.34843	
EYESIZHD	-0.15078	-0.30388	0.06824	0.07270	-0.02339	
CFDMBD	0.06989	0.25091	-0.10207	-0.41963	0.01260	
MBDMBW	0.09422	0.25643	0.18723	-0.18135	-0.23886	
CFAREA	0.07194	0.57773	-0.18595	-0.32694	-0.10542	
CFASP	0.08973	-0.59043	0.20598	0.41874	0.50618	
CFASP2	-0.01935	0.57564	-0.24348	-0.42350	-0.40283	
CFASP22	0.01604	-0.20615	0.31896	-0.04537	-0.09767	
ADFAF	0.16295	-0.22291	0.06427	0.64357	0.12146	
PDFAF	0.31870	0.12921	0.07127	0.14015	0.11069	
	SL	ACFL	CFD	MBD	TLDF	MDFS
JMAX	-0.37738	0.14408	0.03737	0.33785	0.41324	-0.12500
PNERDF	0.05681	-0.10841	0.56580	0.38941	-0.82479	0.47747
AFVMCF	-0.45700	0.48082	-0.11217	0.10517	0.65125	-0.23455
PECPEL	0.33291	-0.40508	0.37326	0.13421	-0.86214	0.38599
PNERPEC	-0.27080	-0.03991	0.42279	0.72191	-0.17179	0.36575
ADFPEL	-0.31059	-0.04071	0.44298	0.90078	-0.12489	0.43870
VMCFDMCF	-0.12656	0.05383	0.11815	0.15611	0.11613	-0.00216
PNERPEL	0.19794	-0.33346	0.50513	0.40185	-0.84740	0.51363
MAXPEC	-0.41980	0.33073	0.00322	0.13999	0.31812	-0.01315
PELAF	-0.10576	0.01615	-0.51271	-0.20896	0.86899	-0.35719
CPINDEX	-0.01401	0.04418	-0.23584	-0.29065	0.17405	-0.23218

Table C.1 *continued*. Matrix of correlation coefficients for morphology measurements taken from fishes of the Roanoke River.

	MDFSMBD	MBW	CPD	CPW	HD	TRUNK
JMAX	-0.34446	0.46269	0.33993	0.00853	0.52136	-0.12492
PNERDF	0.24350	-0.11755	-0.28538	0.31007	0.07001	-0.14998
AFVMCF	-0.33414	0.02463	0.33899	0.09530	0.13748	0.20162
PECPEL	0.33392	0.12346	-0.45252	0.06513	-0.00462	-0.32605
PNERPEC	-0.06898	0.25037	0.09528	0.30654	0.65815	-0.21499
ADFPPEL	-0.08432	0.25161	0.18180	0.32357	0.66421	-0.22878
VMCFDMCF	-0.06098	0.00298	0.75381	0.03450	0.13940	-0.02047
PNERPEL	0.30646	0.07372	-0.37234	0.19041	0.18870	-0.30333
MAXPEC	-0.10414	-0.11298	0.36510	0.03292	0.27468	0.31436
PELAF	-0.24713	-0.01239	0.15681	-0.11099	0.02127	0.31743
CPINDEX	-0.03574	0.00663	0.62011	-0.62029	-0.18033	-0.03797
	PFW	PFL	PECAREA	PECASP	EYELOC	PECPEL
JMAX	0.34044	0.29431	0.10509	0.02278	0.21997	-0.34862
PNERDF	-0.49367	-0.67848	-0.21735	-0.24564	-0.52038	0.76315
AFVMCF	0.35069	0.61265	-0.17884	0.51971	0.16506	-0.72128
PECPEL	-0.39257	-0.71943	0.10291	-0.55713	-0.27004	1.00000
PNERPEC	-0.03488	-0.12921	0.08785	-0.20125	-0.16205	0.19162
ADFPPEL	-0.04665	-0.07036	0.08056	-0.19355	-0.09656	0.15711
VMCFDMCF	0.02519	0.03430	-0.10933	-0.01954	0.24528	-0.25561
PNERPEL	-0.45773	-0.70056	0.06361	-0.50814	-0.35877	0.91217
MAXPEC	0.12805	0.30102	-0.16455	0.35209	0.18689	-0.41053
PELAF	0.43707	0.69804	0.21975	0.30287	0.36847	-0.74789
CPINDEX	0.09459	0.08885	-0.10053	0.06044	0.41173	-0.31923
	EYESIZ	CPL	CFL	EYESIZHD	CFDMBD	MBDMBW
JMAX	0.34642	-0.17771	0.33024	0.00154	-0.19689	0.02792
PNERDF	-0.06357	0.19719	-0.12085	-0.08879	0.30062	0.38335
AFVMCF	0.51889	0.16172	0.19408	0.39942	-0.21119	0.10923
PECPEL	-0.38792	-0.03709	-0.19297	-0.35892	0.30419	-0.00391
PNERPEC	0.23702	-0.01857	0.18007	-0.20232	-0.08850	0.44138
ADFPPEL	0.35655	-0.03419	0.26441	-0.08316	-0.18209	0.56863
VMCFDMCF	-0.06783	0.03424	0.26864	-0.15078	0.06989	0.09422
PNERPEL	-0.20711	0.01304	-0.10199	-0.30388	0.25091	0.25643
MAXPEC	0.26248	-0.09603	0.26949	0.06824	-0.10207	0.18723
PELAF	0.09554	-0.12139	-0.14991	0.07270	-0.41963	-0.18135
CPINDEX	-0.14597	-0.15547	0.34843	-0.02339	0.01260	-0.23886
	CFAREA	CFASP	CFASP2	CFASP22	ADFAF	PDFAF
JMAX	-0.02086	0.20711	-0.22171	0.01023	0.01849	0.21050
PNERDF	0.31303	-0.64485	0.61854	0.13963	-0.52020	-0.13994
AFVMCF	-0.50711	0.26337	-0.29909	0.40080	-0.08325	-0.11301
PECPEL	0.50604	-0.53085	0.53557	-0.24700	-0.29156	-0.00992
PNERPEC	0.34713	-0.28976	0.22816	-0.00705	0.00576	0.35559
ADFPPEL	0.34594	-0.23516	0.20227	-0.05894	0.20275	0.58583
VMCFDMCF	0.07194	0.08973	-0.01935	0.01604	0.16295	0.31870
PNERPEL	0.57773	-0.59043	0.57564	-0.20615	-0.22291	0.12921
MAXPEC	-0.18595	0.20598	-0.24348	0.31896	0.06427	0.07127
PELAF	-0.32694	0.41874	-0.42350	-0.04537	0.64357	0.14015
CPINDEX	-0.10542	0.50618	-0.40283	-0.09767	0.12146	0.11069

Table C.1 *continued*. Matrix of correlation coefficients for morphology measurements taken from fishes of the Roanoke River.

	JMAX	PNERDF	AFVMCF	PECPEL	PNERPEC	ADFPEL
JMAX	1.00000	-0.29165	0.50018	-0.34862	0.34302	0.33878
PNERDF	-0.29165	1.00000	-0.46185	0.76315	0.36871	0.30101
AFVMCF	0.50018	-0.46185	1.00000	-0.72128	-0.02320	0.01193
PECPEL	-0.34862	0.76315	-0.72128	1.00000	0.19162	0.15711
PNERPEC	0.34302	0.36871	-0.02320	0.19162	1.00000	0.70285
ADFPEL	0.33878	0.30101	0.01193	0.15711	0.70285	1.00000
VMCFDMCF	0.27227	-0.18972	0.19368	-0.25561	0.11650	0.20726
PNERPEL	-0.27258	0.84480	-0.65803	0.91217	0.39828	0.39930
MAXPEC	0.21781	-0.20531	0.29304	-0.41053	0.13345	0.11705
PELAF	0.14063	-0.73722	0.39697	-0.74789	-0.27119	-0.19990
CPINDEX	0.21798	-0.45154	0.10102	-0.31923	-0.20684	-0.15249
	VMCFDMCF	PNERPEL	MAXPEC	PELAF	CPINDEX	
JMAX	0.27227	-0.27258	0.21781	0.14063	0.21798	
PNERDF	-0.18972	0.84480	-0.20531	-0.73722	-0.45154	
AFVMCF	0.19368	-0.65803	0.29304	0.39697	0.10102	
PECPEL	-0.25561	0.91217	-0.41053	-0.74789	-0.31923	
PNERPEC	0.11650	0.39828	0.13345	-0.27119	-0.20684	
ADFPEL	0.20726	0.39930	0.11705	-0.19990	-0.15249	
VMCFDMCF	1.00000	-0.18256	0.20623	0.06542	0.52873	
PNERPEL	-0.18256	1.00000	-0.31302	-0.74353	-0.38445	
MAXPEC	0.20623	-0.31302	1.00000	0.28475	0.20016	
PELAF	0.06542	-0.74353	0.28475	1.00000	0.13312	
CPINDEX	0.52873	-0.38445	0.20016	0.13312	1.00000	

Appendix D. Principal components analysis

Results of principal components analysis of morphology traits on 526 individual fishes. For plots, microhabitat guild acronyms are as follows: FG = fast-generalist, FR = fast riffle, PC = pool-covered, PO = pool-open, PR = pool-run, RR = riffle-run, and SR = shallow-rheophilic. Each plot has over 150 hidden observations. Morphology measurements and their acronyms are total length (TL), standard length (SL), axial caudal fin length (ACFL), caudal fin depth (CFD), maximum body depth (MBD), total length of dorsal fin(s) (TLDF), maximum dorsal fin span (MDFS), maximum body width (MBW), caudal peduncle depth (CPD), caudal peduncle width (CPW), head depth (HD), pectoral fin width (PFW), pectoral fin length (PFL), eye position (EP), distance from dorsal fin to anal fin (ADFAF), distance from posterior of dorsal fin to anal fin (PDFAF), upper jaw length (JMAX), pre-dorsal fin length (PNERDF), distance from anal fin to caudal fin (AFVMCF), distance from pectoral fin to pelvic fin (PECPEL), distance from posterior of neurocranium to pectoral fin (PNERPEC), distance from dorsal fin to pelvic fin (ADFPEL), anterior caudal fin depth (VMCFDMCF), distance from neurocranium to pelvic fin (PNERPEL), distance from jaw to pectoral fin (MAXPEC), distance from pelvic fin to anal fin (PELAF), distance from most anterior point of body to the point of greatest body depth (ALEEVY), eye diameter (EYESIZE), caudal peduncle length (CPL), caudal fin length (CFL), ratio of fin height to body depth (MDFSMBD), streamlining (TRUNK), pectoral fin area (PECAREA), pectoral fin aspect ratio (PECASP), eye vertical position (EYELOC), relative eye size (EYESIZHD), ratio of caudal fin depth to body depth (CFDMBD), body compression (MBDMBW), caudal fin area (CFAREA), caudal fin aspect ratio (CFASP), a second caudal fin aspect ratio (CFASP2), a third caudal fin aspect ratio (CFASP22), and caudal peduncle compression index (CPINDEX). For illustrations of original measurements and instructions on how to derive other measurements see Appendix A.

Simple statistics for each morphology trait are given in Table 1. Eigenvalues are reported in Table 2 and loadings on eigenvectors accounting for most variation are given in Table 3. Plots of the first five components follow. Then, plots of the top three loading variables on each component are given.

Table D.1. Simple statistics for each morphology trait.

	ACFL	CFD	MBD	TLDF	MDFS
Mean	0.2790494297	0.2383079848	0.2217300380	0.2386692015	0.1418821293
StD	0.0651901938	0.0566458355	0.0418324473	0.1743377589	0.0400579745
	MDFSMBD	MBW	CPD	CPW	HD
Mean	0.6455323194	0.1656463878	0.1110456274	0.0562357414	0.1409695817
StD	0.1658490475	0.0300073079	0.0206524485	0.0131327847	0.0235677549
	TRUNK	PFW	PFL	PECAREA	PECASP
Mean	0.4436882129	0.1145247148	0.2036501901	1.789866920	0.0296197719
StD	0.0713334873	0.0318218607	0.0454939375	1.050503091	0.0154503170
	EYELOC	PECPEL	EYESIZ	CPL	CFL
Mean	0.7359505703	0.2322243346	0.0582699620	0.1792395437	0.2240304183
StD	0.1160876083	0.0780170620	0.0137546990	0.0441835095	0.0373925257
	EYESIZHD	CFDMBD	MBDMBW	CFAREA	CFASP
Mean	0.4200760456	1.085152091	1.364258555	4.173517110	0.9863498099
StD	0.1032186487	0.224655240	0.281330380	2.479453009	0.2772579739
	CFASP22	ADFAF	PDFAF	JMAX	PNERDF
Mean	0.0159125475	0.3126045627	0.2051140684	0.0753231939	0.2611026616
StD	0.0071330188	0.0566178795	0.0351200162	0.0221894465	0.0873717886
	AFVMCF	PNERPEC	VMCFDMCF	MAXPEC	PELAF
Mean	0.3120912548	0.1621482890	0.1188403042	0.1896958175	0.2490684411
StD	0.0599030903	0.0321920556	0.0168913946	0.0255511189	0.0731214715
			CPINDEX		
		Mean	2.069182510		
		StD	0.662384938		

Table D.2. Eigenvalues of the Correlation Matrix

	Eigenvalue	Difference	Proportion	Cumulative
1	7.98578020	2.02067083	0.2218	0.2218
2	5.96510937	1.25747771	0.1657	0.3875
3	4.70763166	1.93803904	0.1308	0.5183
4	2.76959262	0.48174905	0.0769	0.5952
5	2.28784357	0.22721306	0.0636	0.6588
6	2.06063052	0.58655479	0.0572	0.7160
7	1.47407573	0.09530114	0.0409	0.7570
8	1.37877458	0.37801564	0.0383	0.7953
9	1.00075895	0.07317813	0.0278	0.8231
10	0.92758082	0.17186803	0.0258	0.8488
11	0.75571279	0.20181575	0.0210	0.8698
12	0.55389704	0.05011448	0.0154	0.8852
13	0.50378256	0.04450966	0.0140	0.8992
14	0.45927289	0.01383473	0.0128	0.9120
15	0.44543817	0.06828752	0.0124	0.9243
16	0.37715065	0.05111182	0.0105	0.9348
17	0.32603884	0.03907622	0.0091	0.9439
18	0.28696261	0.02699874	0.0080	0.9518
19	0.25996387	0.01264724	0.0072	0.9591
20	0.24731663	0.05341418	0.0069	0.9659
21	0.19390245	0.00627959	0.0054	0.9713
22	0.18762286	0.03159909	0.0052	0.9765
23	0.15602377	0.00949273	0.0043	0.9809
24	0.14653104	0.03613971	0.0041	0.9849
25	0.11039134	0.02383782	0.0031	0.9880
26	0.08655352	0.01783717	0.0024	0.9904
27	0.06871635	0.00547881	0.0019	0.9923
28	0.06323754	0.00948822	0.0018	0.9941
29	0.05374932	0.01404203	0.0015	0.9956
30	0.03970728	0.00456222	0.0011	0.9967
31	0.03514506	0.00593910	0.0010	0.9976
32	0.02920596	0.00648438	0.0008	0.9984
33	0.02272158	0.00915926	0.0006	0.9991
34	0.01356233	0.00095979	0.0004	0.9995
35	0.01260254	0.00558952	0.0004	0.9998
36	0.00701301		0.0002	1.0000

Table D.3. Eigenvectors.

	Prin1	Prin2	Prin3
ACFL	0.331	0.663	0.046
CFD	-0.552	0.432	0.453
MBD	-0.239	0.212	0.848
TLDF	0.906	-0.141	0.155
MDFS	-0.548	0.070	0.329
MDFSMBD	-0.428	-0.122	-0.171
MBW	0.046	-0.525	0.330
CPD	0.414	0.197	0.298
CPW	-0.173	0.322	0.320
HD	-0.038	-0.158	0.865
TRUNK	0.293	0.348	-0.129
PFW	0.493	-0.353	0.223
PFL	0.763	-0.028	0.201
PECAREA	-0.019	-0.777	0.246
PECASP	0.495	0.677	-0.141
EYELOC	0.445	-0.493	0.050
PECPEL	-0.910	-0.177	0.246
EYESIZ	0.289	0.640	0.380
CPL	-0.089	0.363	-0.194
CFL	0.171	0.387	0.339
EYESIZHD	0.289	0.720	0.193
CFDMBD	-0.416	0.273	-0.126
MBDMBW	-0.215	0.608	0.480
CFAREA	-0.567	-0.383	0.359
CFASP	0.682	-0.136	-0.193
CFASP2	0.092	0.744	0.006
ADFAF	0.358	-0.594	0.278
PDFAF	0.035	-0.379	0.609
JMAX	0.391	-0.030	0.585
PNERDF	-0.871	0.293	0.066
AFVMCF	0.684	0.364	0.218
PNERPEC	-0.302	0.064	0.760
VMCFDMCF	0.215	0.012	0.324
MAXPEC	0.397	-0.224	0.001
PELAF	0.789	-0.224	0.001
CPINDEX	0.789	-0.153	-0.097

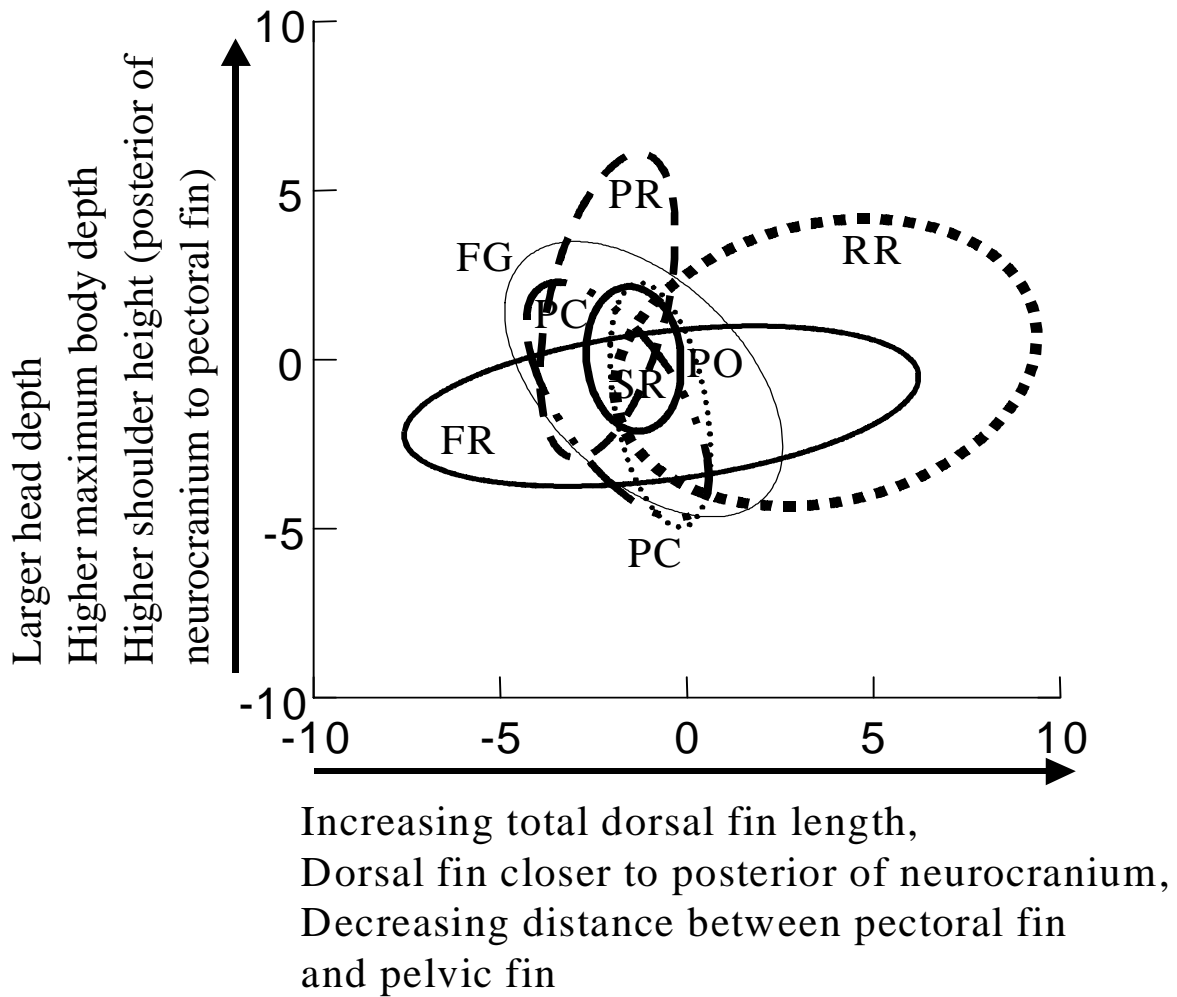

Figure D.1. Plot of principal component one and three showing microhabitat guilds as 95% confidence ellipses of samples.

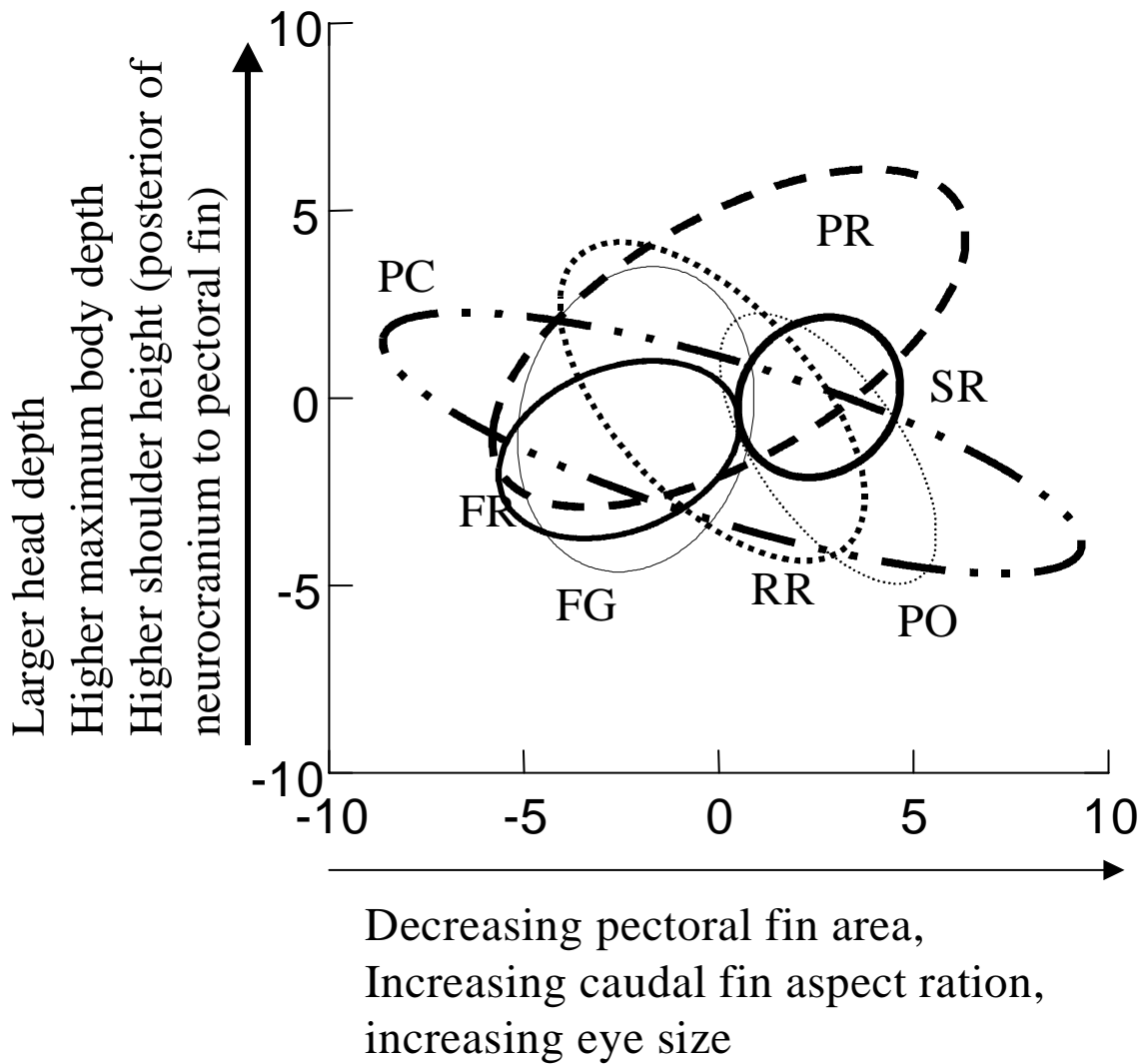

Figure D.2. Plot of principal components two and three showing microhabitat guilds as 95% confidence ellipses around samples.

Appendix E. Mean differences of univariate analysis

The results of SNK means-test when significant differences at the $p < 0.05$ level among guilds were indicated from an unbalanced ANOVA. Means demarcated with the same letter are not significantly different. Morphology measurements and their acronyms are,, pectoral fin width (PFW), pectoral fin length (PFL), pre-dorsal fin length (PNERDF), distance from anal fin to caudal fin (AFVMCF), distance from pectoral fin to pelvic fin (PECPEL), distance from pelvic fin to anal fin (PELAF), and eye vertical position (EYELOC). For illustrations of original measurements and instructions on how to derive other measurements see Appendix A.

Table E.1. Results of the Student-Newman-Keuls Test for morphology traits and microhabitat guilds.

Student-Newman-Keuls Test for axial caudal fin length (ACFL).			
SNK Grouping	Mean	N	Guild
A	0.34905	2	Pool-Open
A			
A	0.34025	2	Shallow-Rheophilic
A			
B A	0.28945	4	Riffle-Run
B A			
B A	0.24931	6	Pool-Cover
B A			
B A	0.24704	3	Pool-Run
B			
B	0.22766	4	Fast-Generalist
B			
B	0.22415	2	Fast-Riffle

Table E.1 *continued.* Results for microhabitat guilds.

Student-Newman-Keuls Test for caudal fin depth (CFD)				
SNK Grouping	Mean	N	Guild	
A	0.28034	3	Pool-Run	
A				
A	0.27908	2	Shallow-Rheophilic	
A				
A	0.24979	6	Pool-Cover	
A				
A	0.24155	2	Pool-Open	
A				
A	0.21858	4	Fast-Generalist	
A				
A	0.20535	4	Riffle-Run	
A				
A	0.18492	2	Fast-Riffle	

Student-Newman-Keuls Test for total length of dorsal fin(s) (TLDF)				
SNK Grouping	Mean	N	Guild	
A	0.4374	4	Riffle-Run	
A				
A	0.3191	2	Fast-Riffle	
A				
A	0.2125	6	Pool-Cover	
A				
A	0.1501	3	Pool-Run	
A				
A	0.1400	4	Fast-Generalist	
A				
A	0.1215	2	Pool-Open	
A				
A	0.1178	2	Shallow-Rheophilic	

Table E.1 *continued.* Results for microhabitat guilds.

Student-Newman-Keuls Test for pectoral fin length (PFL)			
SNK Grouping	Mean	N	Guild
A	0.24803	4	Riffle-Run
A			
A	0.22717	2	Fast-Riffle
A			
A	0.18854	2	Shallow-Rheophilic
A			
A	0.18808	3	Pool-Run
A			
A	0.18369	6	Pool-Cover
A			
A	0.17559	4	Fast-Generalist
A			
A	0.16119	2	Pool-Open

Student-Newman-Keuls Test for vertical position of eye on the head (EYELOC)			
SNK Grouping	Mean	N	Guild
A	0.82269	4	Fast-Generalist
A			
B A	0.78908	4	Riffle-Run
B A			
B A	0.77966	2	Fast-Riffle
B A			
B A	0.69795	3	Pool-Run
B A			
B A	0.68634	6	Pool-Cover
B A			
B A	0.65810	2	Shallow-Rheophilic
B			
B	0.62917	2	Pool-Open

Table E.1 *continued.* Results for microhabitat guilds.

Student-Newman-Keuls Test for the distance between the pelvic fin and
anal fin (PELAF)

SNK Grouping	Mean	N	Guild
A	0.31428	4	Riffle-Run
A			
A	0.31108	2	Fast-Riffle
A			
A	0.24787	6	Pool-Cover
A			
A	0.22575	4	Fast-Generalist
A			
A	0.21549	3	Pool-Run
A			
A	0.20012	2	Pool-Open
A			
A	0.18122	2	Shallow-Rheophilic

Table E.2 Results of the Student-Newman-Keuls Test for morphology traits and mesohabitat guilds. Guilds with the same letter are not statistically different at alpha=0.05.

Student-Newman-Keuls Test for caudal fin depth(CFD)			
SNK Grouping	Mean	N	Guild
A	0.26065	5	Limnophilic Guild
A			
A	0.24702	9	Generalist Guild
B	0.19854	6	Rheophilic Guild

Student-Newman-Keuls Test for total length of dorsal fin (TLDF)			
SNK Grouping	Mean	N	Guild
A	0.39795	6	Rheophilic Guild
B	0.19402	5	Limnophilic Guild
B			
B	0.13895	9	Generalist Guild

Student-Newman-Keuls Test for pectoral fin width (PFW)			
SNK Grouping	Mean	N	Guild
A	0.13155	6	Rheophilic Guild
B	0.10402	9	Generalist Guild
B			
B	0.09631	5	Limnophilic Guild

Student-Newman-Keuls Test for pectoral fin length (PFL)			
SNK Grouping	Mean	N	Guild
A	0.24108	6	Rheophilic Guild
B	0.18032	5	Limnophilic Guild
B			
B	0.17978	9	Generalist Guild

Table E.2 *continued*. Results for mesohabitat guilds.

Student-Newman-Keuls Test for the distance between the pectoral fin and pelvic fin (PECPEL)			
SNK Grouping	Mean	N	Guild
A	0.27234	9	Generalist Guild
A			
B A	0.24392	5	Limnophilic Guild
B			
B	0.17805	6	Rheophilic Guild

Student-Newman-Keuls Test for the position of the dorsal fin back from the head (PNERDF)			
SNK Grouping	Mean	N	Guild
A	0.31260	5	Limnophilic Guild
A			
A	0.28966	9	Generalist Guild
B	0.18788	6	Rheophilic Guild

Student-Newman-Keuls Test for the distance from the distance from anal fin to caudal fin (AFVMCF)			
SNK Grouping	Mean	N	Guild
A	0.34215	6	Rheophilic Guild
A			
A	0.32680	5	Limnophilic Guild
A			
A	0.27981	9	Generalist Guild

Student-Newman-Keuls Test for the distance between the pelvic fin and anal fin (PELAF)			
SNK Grouping	Mean	N	Guild
A	0.31321	6	Rheophilic Guild
B	0.21558	5	Limnophilic Guild
B			
B	0.21441	9	Generalist Guild

Appendix F. Habitat references

Table F.1. Target species and their surrogates as identified from the primary literature and Jenkins and Burkhead (1994).

Target Species	Reference (bold)	Surrogate(s)
Target Species	Target Species (italics)	
	Not Identified	
Mottled Sculpin	<i>Cottus bairdi</i>	Not Available
	Porterfield et al., 1999	
Fantail darter	<i>Etheostoma flabellare</i>	<i>E. kennicotti</i>
Riverweed darter	<i>Etheostoma podostemone</i>	<i>E. vitreum</i>
	Wood, 1996	
Sharphead darter	<i>Etheostoma acuticeps</i>	<i>E. jordani</i>
Redline darter	<i>Etheostoma rufilineatum</i>	<i>E. bellum</i>
	Wood and Mayden, 1997	
Banded Darter	<i>Etheostoma zonale</i>	<i>Etheostoma blennioides</i>
Greenside darter	<i>Etheostoma blennioides</i>	<i>Etheostoma zonale</i>
	Page, 1981	
TN Snubnose darter	<i>Etheostoma simoterum</i>	An undescribed species
	Jenkins and Burkhead, 1994	
Roanoke darter	<i>Percina roanoka</i>	<i>P. crassa</i>
Roanoke logperch	<i>Percina rex</i>	<i>P. burtoni</i>
Guilt Darter	<i>Percina evides</i>	<i>P. palmaris</i>
	Page, 1981	
Tangerine darter	<i>Percina aurantiaca</i>	No close relative (subgenus: Hypohomus)
	Not Identified	
Central stoneroller	<i>Campostoma anomalum</i>	Not available
	Grady and LeGrande, 1992	
Margined madtom	<i>Noturus insignis</i>	<i>N. gilberti</i>
Orangefin madtom	<i>Noturus gilberti</i>	<i>N. insignis</i>

Table F.1 *continued*. Target species and their surrogates as identified from the primary literature and Jenkins and Burkhead (1994).

Target Species	Reference (bold)	Surrogate(s)
Target Species	Target Species (italics)	
Smith, 1992		
Silver redhorse	<i>Moxostoma anisurum</i>	<i>M. pappillosum</i>
Roanoke hog sucker	<i>Hypentelium roanokense</i>	<i>H. nigricans</i>
Northern hog sucker	<i>Hypentelium nigricans</i>	<i>H. roanokense</i>
White sucker	<i>Catostomus commersoni</i>	<i>C. bernardini</i> or <i>C. insignis</i>
Black jumprock	<i>Scartomyzon cervinus</i>	<i>S. rupiscartes</i>
Torrent sucker	<i>Thoburnia rhothoeca</i>	<i>T. hamiltoni</i>
Wainwright and Lauder, 1992		
Redbreast sunfish	<i>Lepomis auritus</i>	<i>L. megalotis</i> or <i>L. gulosus</i>
Not Identified		
Bluehead chub	<i>Nocomis leptocephalus</i>	Not available.
Jenkins and Burkhead, 1994		
River chub	<i>Nocomis micropogon</i>	<i>N. platyrhynchus</i>
Jenkins and Burkhead, 1994		
Spottail shiner	<i>Notropis hudsonius</i>	Not available.
Whitemouth shiner	<i>Notropis alborus</i>	<i>N. heterolepis</i>
Wiley and Mayden, 1985		
Tennessee shiner	<i>Notropis leuciodus</i>	<i>N. semperasper</i> or <i>N. scepticus</i>
Gilbert, 1969		
Telescope shiner	<i>Notropis telescopus</i>	<i>N. ariommus</i>
Gold et al., 1992		
Mimic shiner	<i>Notropis volucellus</i>	<i>N. girardi</i> or <i>N. potteri</i> <i>N. chrosomus</i> or <i>N. nubilus</i>
Warren et al., 1994		
Swallowtail shiner	<i>Notropis procne</i>	<i>N. ludibundus</i>

Table F.1 *continued*. Target species and their surrogates as identified from the primary literature and Jenkins and Burkhead (1994).

Target Species	Reference (bold)	Surrogate(s)
Target Species	Target Species (italics)	
Dowling et al., 1992		
Crescent shiner	<i>Luxilus cerasinus</i>	<i>L. isolepis</i> or <i>L. albeolus</i> or <i>L. zonatus</i>
White shiner	<i>Luxilus albeolus</i>	<i>L. cornutus</i>
Striped shiner	<i>Luxilus chrysocephalus</i>	<i>L. cornutus</i>
Warpaint shiner	<i>Luxilus coccogenis</i>	<i>L. zonistius</i>
Madyen, 1989		
Bigeye chub	<i>Hybopsis amblops</i>	<i>H. rubrifrons</i> or <i>H. hypsinotus</i> <i>H. amnis</i> or <i>H. winchelli</i> or <i>H. lineapunctatus</i>
Mayden, 1989		
Slender chub	<i>Erimystax cahni</i>	<i>E. insignis</i> or <i>E. x-puctata</i>
Blotched chub	<i>Erimystax insignis</i>	<i>E. cahni</i> or <i>E. dissimilis</i>
Mayden, 1989		
Stargazing minnow	<i>Phenacobius uranops</i>	<i>P. crassilabrum</i>
Mayden, 1989		
Whitetail shiner	<i>Cyprinella galactura</i>	<i>C. venusta</i>
Steelcolor shiner	<i>Cyprinella whipplei</i>	<i>C. camura</i>
Jenkins and Burkhead, 1994		
Spotfin chub	<i>Cyprinella monocha</i>	<i>C. galactura</i>
Woodman, 1992		
East. blacknose dace	<i>Rhinichthys atratulus atratulus</i>	<i>R. cobitus</i> or <i>R. falcatus</i>
Jenkins and Burkhead, 1994		
Mt. redbelly dace	<i>Phoxinus oreas</i>	<i>P. tennesseensis</i>
Tennessee Dace	<i>P. tennesseensis</i>	<i>P. oreas</i>
Mayden, 1989		
Bluntnose minnow	<i>Pimephales notatus</i>	<i>P. promelas</i>

Table F.2. Habitat comparisons among target species and their surrogates. Rare, threatened or endangered species are marked with an asterisk (Page and Burr, 1991, Jenkins and Burkhead, 1994). The acronyms NA, Lg., and Sm. mean information was “not available”, “large” and “small”, respectively. The word “to” means that a species used all habitat between the categories it connects. When a comma separates habitat conditions, it means the reported habitat use was not continuous.

Variable	Target Species	Surrogate Species
Species	<i>Etheostoma flabellare</i>	<i>E. kennicotti</i>
Mesohabitat	Riffle	Pool
Microhabitat		
Depth cm	Shallow	Shallow
Current cm/s	Moderate to Fast	Slow
Substrate	Sm. gravel to boulder	Bedrock
Species	<i>Etheostoma podostemone</i>	<i>E. vitreum</i>
Mesohabitat	Riffle	Run
Microhabitat		
Depth cm	Shallow	NA
Current cm/s	Moderate to fast	NA
Substrate	Lg. gravel to boulder	Sand
Species	<i>Percina roanoka</i>	<i>P. crassa</i>
Mesohabitat	Riffle	Riffle, Run
Microhabitat		
Depth cm	Shallow	NA
Current cm/s	Moderate to fast	NA
Substrate	Sm. gravel to boulder	Sm. gravel to Lg. cobble
Species	<i>Percina rex</i>*	<i>P. burtoni</i>
Mesohabitat	Pool, Run	Run, Riffle
Microhabitat		
Depth cm	Shallow to medium	Shallow to medium
Current cm/s	Moderate	Moderate
Substrate	Sm. gravel to Lg. cobble	Sm. cobble
Species	<i>Percina evides</i>	<i>P. palmaris</i>
Mesohabitat	Riffle	Riffle
Microhabitat		
Depth cm	Shallow	Shallow
Current cm/s	Fast	Medium to fast
Substrate	Pebble to Lg. cobble	Pebble to boulder
Species	<i>Etheostoma acuticeps</i>*	<i>E. jordani</i>
Mesohabitat	Run, Riffle	Riffle
Microhabitat		
Depth cm	Shallow to medium	Shallow
Current cm/s	Moderate to swift	Moderate to swift
Substrate	Lg. cobble to boulder	Lg. cobble to boulder

Table F.2 *continued.* Habitat comparisons among target species and their surrogates.

Variable	Target Species	Surrogate Species
Species	<i>Etheostoma rufilineatum</i>	<i>E. bellum</i>
Mesohabitat	Run, Riffle	Riffle
Microhabitat		
Depth cm	Shallow	Shallow
Current cm/s	Swift	Moderate to swift
Substrate	Pebble to boulder	Pebble to cobble
Species	<i>Etheostoma zonale</i>	<i>Etheostoma blennioides</i>
Mesohabitat	Run, Riffle	Run, Riffle
Microhabitat		
Depth cm	Shallow	Shallow
Current cm/s	Slow to swift	Moderate
Substrate	Pebble to Lg. gravel	Pebble to Lg. cobble
Species	<i>Etheostoma blennioides</i>	<i>Etheostoma zonale</i>
Mesohabitat	Run, Riffle	Run, Riffle
Microhabitat		
Depth cm	Shallow	Shallow
Current cm/s	Moderate	Slow
Substrate	Pebble to Lg. cobble	Sm. gravel to pebble
Species	<i>Noturus insignis</i>	<i>N. gilberti*</i>
Mesohabitat	Run, Riffle	Run, Riffle
Microhabitat		
Depth cm	Shallow	Shallow
Current cm/s	Moderate	Swift
Substrate Species	Small to Lg. cobble	Sm. to Lg. cobble
Species	<i>Noturus gilberti*</i>	<i>N. insignis</i>
Mesohabitat	Run, Riffle	Run, Riffle
Microhabitat		
Depth cm	Shallow	Shallow
Current cm/s	Swift	Moderate
Substrate Species	Sm. to Lg. cobble	Sm. to Lg. cobble
Species	<i>Moxostoma anisurum</i>	<i>M. pappillosum</i>
Mesohabitat	Pool	Pool
Microhabitat		
Depth cm	NA	NA
Current cm/s	Slow	Slow
Substrate	Silt to boulder	NA
Species	<i>Hypentelium roanokense</i>	<i>H. nigricans</i>
Mesohabitat	Run	Run
Microhabitat		
Depth cm	Medium	Shallow to medium
Current cm/s	Moderate	Slow to moderate
Substrate	Lg. gravel to Sm cobble	Sm. to Lg. cobble

Table F.2 *continued.* Habitat comparisons among target species and their surrogates.

Variable	Target Species	Surrogate Species
Species	<i>Hypentelium nigricans</i>	<i>H. roanokense</i>
Mesohabitat	Run	Run
Microhabitat		
Depth cm	Shallow to medium	Medium
Current cm/s	Slow to moderate	Moderate
Substrate	Sm. to Lg. cobble	Lg. gravel to Sm. cobble
Species	<i>Catostomus commersoni</i>	<i>C. insignis</i>
Mesohabitat	Pool	Pool
Microhabitat		
Depth cm	Shallow to deep	Shallow
Current cm/s	Slow	Medium
Substrate	Sand to Sm. cobble	Pebble (17-64mm)
Species	<i>Scartomyzon cervinum*</i>	<i>S. rupiscartes</i>
Mesohabitat	Riffle, Run	Riffle, Run
Microhabitat		
Depth cm	Shallow	NA
Current cm/s	Moderate	NA
Substrate	Sm. cobble to boulder	Sand to bedrock
Species	<i>Thoburnia rhothoeca</i>	<i>T. hamiltoni</i>
Mesohabitat	Riffle	Riffle, Rrun
Microhabitat		
Depth cm	Shallow	Shallow
Current cm/s	Moderate	Moderate to swift
Substrate	Sm. cobble to boulder	Lg. gravel to Lg. cobble
Species	<i>Lepomis auritus</i>	<i>L. megalotis</i>
Mesohabitat	pool	Pool
Microhabitat		
Depth cm	Shallow to medium	Shallow
Current cm/s	Slow	Slow
Substrate	Sand to boulder	NA
Species	<i>Nocomis micropogon</i>	<i>N. platyrhynchus</i>
Mesohabitat	Pool, Run	Riffle
Microhabitat		
Depth cm	NA	Shallow to deep
Current cm/s	Slow	Slow
Substrate	Pebble to bedrock	Silt to bedrock
Species	<i>Notropis alborus*</i>	<i>N. heterolepis</i>
Mesohabitat	Pool	Pool
Microhabitat		
Depth cm	NA	NA
Current cm/s	Slow	Slow
Substrate	Silt to Lg. gravel, Bedrock	NA

Table F.2 *continued.* Habitat comparisons among target species and their surrogates.

Variable	Target Species	Surrogate Species
Species	<i>Notropis leuciodus</i>	<i>N. semperasper</i>
Mesohabitat	Run	Pool
Microhabitat		
Depth cm	NA	Shallow to medium
Current cm/s	Slow	Slow
Substrate	NA	Sm. gravel to boulder
Species	<i>Notropis telescopus</i>	<i>N. ariommus*</i>
Mesohabitat	Run, Pool	Run
Microhabitat		
Depth cm	NA	Medium to deep
Current cm/s	NA	Moderate
Substrate	Silt, Bedrock	Sm. gravel to Lg. cobble
Species	<i>Notropis volucellus</i>	<i>N. girardi</i>
Mesohabitat	Pool	Pool
Microhabitat		
Depth cm	Shallow	Shallow
Current cm/s	Slow	Slow to moderate
Substrate	Sm. gravel to Sm. cobble	Sand
Species	<i>Notropis procne</i>	<i>N. ludibundus</i>
Mesohabitat	Pool	Run, Pool
Microhabitat		
Depth cm	Shallow to medium	Shallow
Current cm/s	Slow	Slow
Substrate	Sm. gravel to Lg. cobble	Silt to bedrock
Species	<i>Luxilus cerasinus</i>	<i>L. albeolus</i>
Mesohabitat	Pool	Pool
Microhabitat		
Depth cm	Shallow	Shallow to medium
Current cm/s	Slow	Slow to moderate
Substrate	Sm. to Lg. cobble	Lg. gravel to Lg. cobble
Species	<i>Luxilus albeolus</i>	<i>L. cornutus</i>
Mesohabitat	Pool	Pool
Microhabitat		
Depth cm	Shallow to medium	Medium to deep
Current cm/s	Slow to moderate	Slow
Substrate	Lg. gravel to Lg. cobble	Sm. gravel to Lg. cobble
Species	<i>Luxilus chrysocephalus</i>	<i>L. cornutus</i>
Mesohabitat	Pool	Pool
Microhabitat		
Depth cm	Shallow	Medium to deep
Current cm/s	Slow	Slow
Substrate	Sm. gravel to Lg. cobble	Sm. gravel to Lg. cobble

Table F.2 *continued.* Habitat comparisons among target species and their surrogates.

Variable	Target Species	Surrogate Species
Species	<i>Luxilus coccogenis</i>	<i>L. zonistius</i>
Mesohabitat	Riffle, Pool	Pool
Microhabitat		
Depth cm	Shallow	NA
Current cm/s	Moderate	NA
Substrate	Silt to bedrock	Sm. gravel to bedrock
Species	<i>Hybopsis amblops</i>	<i>H. lineapunctatus</i>
Mesohabitat	Pool	Pool
Microhabitat		
Depth cm	Shallow	NA
Current cm/s	Slow	Slow
Substrate	Sand to Lg. cobble	Sand, Sm. gravel to bedrock
Species	<i>Erimystax cahni</i>*	<i>E. insignis</i>
Mesohabitat	Run, Riffle	Run, Riffle
Microhabitat		
Depth cm	Medium to deep	Shallow
Current cm/s	Swift	Moderate
Substrate	Sm. gravel	Sm. gravel to Lg. cobble
Species	<i>Erimystax insignis</i>	<i>E. cahni</i>*
Mesohabitat	Run, Riffle	Run, Riffle
Microhabitat		
Depth cm	Shallow	Medium to deep
Current cm/s	Moderate	Swift
Substrate	Sm. gravel to Lg. cobble	Sm. gravel
Species	<i>Phenacobius uranops</i>	<i>P. crassilabrum</i>
Mesohabitat	Run, Riffle	Run, Riffle
Microhabitat		
Depth cm	Medium	NA
Current cm/s	Moderate	NA
Substrate	Sm gravel to Lg. cobble	Sm. gravel to boulder
Species	<i>Cyprinella galactura</i>	<i>C. venusta</i>
Mesohabitat	Run	Pool, Run
Microhabitat		
Depth cm	Shallow	NA
Current cm/s	Moderate	Slow
Substrate	Sand to Lg. cobble	Sand
Species	<i>Cyprinella whipplei</i>*	<i>C. camura</i>
Mesohabitat	Run, Pool	Riffle
Microhabitat		
Depth cm	NA	NA
Current cm/s	NA	Swift
Substrate	Silt to bedrock	Sm. gravel to Lg. cobble

Table F.2 *continued.* Habitat comparisons among target species and their surrogates.

Variable	Target Species	Surrogate Species
Species	<i>Cyprinella monochoa</i>*	<i>C. galactura</i>
Mesohabitat	Riffle, Run	Run
Microhabitat		
Depth cm	Shallow to medium	Shallow
Current cm/s	Moderate to swift	Moderate
Substrate	Lg. gravel to bedrock	Sand to Lg. cobble
Species	<i>Rhinichthys atratulus atratulus</i>	<i>R. cobitus</i>
Mesohabitat	Riffle	Riffle
Microhabitat		
Depth cm	Shallow	Shallow
Current cm/s	Moderate	Moderate
Substrate	Lg. gravel to Lg. cobble	Sm. cobble to boulder
Species	<i>Phoxinus oreas</i>	<i>P. tennesseensis</i>*
Mesohabitat	Pool	Pool
Microhabitat		
Depth cm	Shallow	NA
Current cm/s	Slow	Slow
Substrate	Sm. cobble	NA
Species	<i>Phoxinus tennesseensis</i>*	<i>P. oreas</i>
Mesohabitat	Pool	Pool
Microhabitat		
Depth cm	NA	Shallow
Current cm/s	Slow	Slow
Substrate	NA	Sm. cobble
Species	<i>Pimephales notatus</i>	<i>P. promelas</i>
Mesohabitat	Pool	Pool
Microhabitat		
Depth cm	Shallow	Shallow
Current cm/s	Slow	Slow
Substrate	Sm. gravel to boulder	Silt

Table F.3. Habitat information for two additional darters within the subgenera *Percina*. used to compare with *Percina rex*. The acronyms NA, Lg., and Sm. mean information was “not available”, “large” and “small”, respectively. The word “to” means that a species used all habitat between the categories it connects. When a comma separates habitat conditions, it means the reported habitat use was not continuous.

Habitat Categories	Darters
Species	<i>P. burtoni</i>
Mesohabitat	Runs/riffles
Microhabitat	
Depth cm	Shallow to medium
Current cm/s	Moderate
Substrate	Small cobble
Species	<i>P. caprodes</i>
Mesohabitat	Riffle to Pool
Microhabitat	
Depth cm	Shallow to Medium
Current cm/s	Moderate to swift
Substrate	Gravel to boulder

Table F.4. Additional darters used for comparisons among members of darter subgenera *Nothonotus*. The acronyms NA, Lg., and Sm. mean information was “not available”, “large” and “small”, respectively. The word “to” means that a species used all habitat between the categories it connects. When a comma separates habitat conditions, it means the reported habitat use was not continuous. Table F.4 *continued*. Habitat comparisons among members of a subgenera (darters).

Habitat Categories	Darters
Species	<i>E. maculatum</i>
Mesohabitat	Riffle
Microhabitat	
Depth cm	Shallow
Current cm/s	Moderate to swift
Substrate	pebble to large cobble
Species	<i>E. camarum</i>
Mesohabitat	Riffle
Microhabitat	
Depth cm	Shallow
Current cm/s	Moderate to swift
Substrate	pebble to large cobble

Table F.5. List of habitat references for target and surrogate species used in Chapter 2. All habitat information is for adult fishes. Common names are in the left column, scientific names are in the middle column and habitat references are in the right column.

Mottled Sculpin	<i>Cottus bairdi</i>	Vadas, 1994
Piedmont darter	<i>Percina crassa</i>	Jenkins and Burkhead, 1994
Blotchside darter	<i>P. burtoni</i>	Etnier and Starnes, 1993
Bronze darter	<i>P. palmaris</i>	Freeman et al., 1997
Roanoke darter	<i>P. roanoka</i>	Matthews et al., 1982; Vadas, 1994
Roanoke logperch	<i>P. rex</i>	Vadas, 1994
Tangerine darter	<i>P. aurantiaca</i>	Temple, 1997
Guilt Darter	<i>P. evides</i>	Temple, 1997
Logperch	<i>P. caprodes</i>	Welsh and Perry, 1998b
Stripetail darter	<i>Etheostoma kennicotti</i>	Page, 1975
Greenbreast darter	<i>E. jordani</i>	Freeman et al., 1997
Fantail darter	<i>E. flabellare</i>	Matthews et al., 1982; Vadas, 1994
Riverweed darter	<i>E. podostemone</i>	Matthews et al., 1982; Vadas, 1994
Sharphead darter	<i>E. acuticeps</i>	Terwilliger et al., 1995
Redline darter	<i>E. rufilineatum</i>	Temple, 1997
Banded Darter	<i>E. zonale</i>	Kessler et al., 1995; Temple, 1997
Greenside darter	<i>E. blennioides</i>	Kessler et al., 1995; Temple, 1997
TN Snubnose darter	<i>E. simoterum</i>	Temple, 1997
Glassy darter	<i>E. vitreum</i>	Fischer et al., 1992
Greenside darter	<i>E. blennioides</i>	Kessler et al. 1995; Stauffer et al., 1996; Temple 1997
Orangefin darter	<i>E. bellum</i>	Fisher, 1990; Page and Burr, 1991; Kessler et al., 1995
Spotted darter	<i>E. maculatum</i>	Kessler and Thorp, 1993; Kessler et al., 1995
Bluebreast darter	<i>E. camurum</i>	Welsh and Perry, 1998b
Orangefin madtom	<i>Noturus gilberti</i>	Simonson and Neves, 1992; Vadas, 1994
Margined madtom	<i>N. insignis</i>	Vadas, 1994

Table F.5 *continued.* List of habitat references for target and surrogate species used in Chapter 2.

White sucker	<i>Catostomus commersoni</i>	Moody, 1989; Vadas, 1994
Yaqui sucker	<i>Catostoma bernardini</i>	Page and Burr, 1991
Sonora sucker	<i>C. insignis</i>	Rinne, 1992
Silver redhorse	<i>Moxostoma anisurum</i>	Vadas, 1994
V-lip redhorse	<i>Moxostoma pappillosum</i>	Jenkins and Burkhead, 1994
River redhorse	<i>Moxostoma carinatum</i>	Robison and Buchanan, 1988; Jenkins and Burkhead, 1994
Northern hog sucker	<i>Hypentelium nigricans</i>	Moody, 1989; Vadas, 1994; Matheney and Rabeni, 1995
Roanoke hog sucker	<i>H. roanokense</i>	Vadas, 1994
Rustyside sucker	<i>Thoburnia hamilton</i>	Raney and Lachner, 1946; Jenkins and Burkhead, 1994
Torrent sucker	<i>Thoburnia rhothoeca</i>	Vadas, 1994
Black jumprock	<i>Scartomyzon cervinus</i>	Vadas, 1994
Striped jumprock	<i>Scartomyzon rupiscartes</i>	Page and Burr, 1991
Longear sunfish	<i>Lepomis megalotis</i>	Schaefer et al., 1999
Redbreast sunfish	<i>Lepomis auritus</i>	Vadas, 1994
Bigmouth chub	<i>Nocomis platyrhynchus</i>	Lobb and Orth, 1988
Bluehead chub	<i>Nocomis leptcephalus</i>	Vadas, 1994
River chub	<i>Nocomis micropogon</i>	Temple, 1997
Central stoneroller	<i>Campostoma anomalum</i>	Vadas, 1994; Temple, 1997
Blacknose shiner	<i>Notropis heterolepis</i>	Trautman, 1957
Roughhead shiner	<i>N. semperasper</i>	Jenkins and Burkhead, 1975
Sandbar shiner	<i>N. szepticus</i>	Harrell and Cloutman, 1978
Popeye shiner	<i>N. ariommus</i>	Jenkins and Burkhead, 1994
Arkansas River shiner	<i>N. girardi</i>	Matthews and Hill, 1980; Polivka, 1999
Rainbow shiner	<i>N. chrosomus</i>	Etnier and Starnes, 1993
Ozark minnow	<i>N. nubilus</i>	McNeely, 1987; Robison and Buchana, 1988
Sand shiner	<i>N. ludibundus</i>	Aadland, 1993
Spottail shiner	<i>Notropis hudsonius</i>	Vadas, 1994
Whitemouth shiner	<i>Notropis alborus</i>	Terwilliger et al., 1995
Tennessee shiner	<i>Notropis leuciodus</i>	Temple, 1997
Telescope shiner	<i>Notropis telescopus</i>	Temple, 1997
Mimic shiner	<i>Notropis volucellus</i>	Vadas, 1994
Swallowtail shiner	<i>Notropis procne</i>	Vadas, 1994

Table F.5 *continued.* List of habitat references for target and surrogate species used in Chapter 2.

Blacktail shiner	<i>Cyprinella venusta</i>	Robison and Buchanan, 1988
Bluntnose shiner	<i>C. camura</i>	Robison and Buchanan, 1988
Whitetail shiner	<i>C. galactura</i>	Outtern, 1958; Temple, 1997
Steelcolor shiner	<i>C. whipplei</i>	Terwilliger et al., 1995
Spotfin chub	<i>C. monocha</i>	Jenkins and Burkhead, 1984
White shiner	<i>Luxilus albeolus</i>	Vadas, 1994
Common shiner	<i>L. cornutus</i>	Moody, 1989; Aadland, 1993
Bandfin shiner	<i>L. zonistius</i>	Page and Burr, 1991
Crescent shiner	<i>L. cerasinus</i>	Vadas, 1994
Striped shiner	<i>L. chrysocephalus</i>	Temple, 1997
Warpaint shiner	<i>L. coccogenis</i>	Temple, 1997
Lined chub	<i>Hybopsis lineapunctatus</i>	Page and Burr, 1991; Etnier and Starnes, 1993
Bigeye chub	<i>H. amblops</i>	Temple, 1997
Blotched chub	<i>Erimystax insignis</i>	Jenkins and Burkhead, 1994; Temple, 1997
Gravel chub	<i>E. x-punctata</i>	Moss, 1983
Slender Chub	<i>E. cahni</i>	Jenkins and Burkhead, 1994; Terwilliger et al., 1995
Streamline chub	<i>E. dissimilis</i>	Jenkins and Burkhead, 1994
Fatlips minnow	<i>Phenacobius crassilabrum</i>	Jenkins and Burkhead, 1994
Stargazing minnow	<i>Phenacobius uranops</i>	Temple, 1997
Loach minnow	<i>Rhinichthys cobitus</i>	Rinne, 1992
East. blacknose dace	<i>R. atratulus atratulus</i>	Vadas, 1994
Tennessee dace	<i>Phoxinus tennesseensis</i>	Jenkins and Burkhead, 1994
Mtn. Red Belly dace	<i>P. oreas</i>	Vadas, 1994
Bluntnose minnow	<i>Pimephales notatus</i>	Vadas, 1994
Fathead minnow	<i>P. promelas</i>	Robison and Buchanan, 1988; Jenkins and Burkhead, 1994

Appendix G. Correlations of morphology within fish families

Correlation matrix for morphology variables by family. Illustrations for each trait are given in Appendix A. Morphology measurements and their acronyms are total length (TL), standard length (SL), axial caudal fin length (ACFL), caudal fin depth (CFD), maximum body depth (MBD), total length of dorsal fin(s) (TLDF), maximum dorsal fin span (MDFS), maximum body width (MBW), caudal peduncle depth (CPD), caudal peduncle width (CPW), head depth (HD), pectoral fin width (PFW), pectoral fin length (PFL), eye position (EP), distance from dorsal fin to anal fin (ADFAF), distance from posterior of dorsal fin to anal fin (PDFAF), upper jaw length (JMAX), pre-dorsal fin length (PNERDF), distance from anal fin to caudal fin (AFVMCF), distance from pectoral fin to pelvic fin (PECPEL), distance from posterior of neurocranium to pectoral fin (PNERPEC), distance from dorsal fin to pelvic fin (ADFPEL), anterior caudal fin depth (VMCFDMCF), distance from neurocranium to pelvic fin (PNERPEL), distance from jaw to pectoral fin (MAXPEC), distance from pelvic fin to anal fin (PELAF), distance from most anterior point of body to the point of greatest body depth (ALEEVY), eye diameter (EYESIZE), caudal peduncle length (CPL), caudal fin length (CFL), ratio of fin height to body depth (MDFSMBD), streamlining (TRUNK), pectoral fin area (PECAREA), pectoral fin aspect ratio (PECASP), eye vertical position (EYELOC), relative eye size (EYESIZHD), ratio of caudal fin depth to body depth (CFDMBD), body compression (MBDMBW), caudal fin area (CFAREA), caudal fin aspect ratio (CFASP), a second caudal fin aspect ratio (CFASP2), a third caudal fin aspect ratio (CFASP22), and caudal peduncle compression index (CPINDEX). For illustrations of original measurements and for instructions on how to derive other measurements see Appendix A.

Table G.1. Species and samples sizes used in analyses of Chapter 3.

Family	Common Name	Species	Sample Size	Habitat Reference
Darters				
	Tangerine darter	<i>Percina aurantiaca</i>	10	Temple 1997
	Roanoke darter	<i>Percina roanoka</i>	9	Vadas 1994
	Guilt Darter	<i>Percina evides</i>	13	Temple 1997
	Roanoke log perch	<i>Percina rex</i>	14	Vadas 1994
	Fantail darter	<i>Etheostoma flabellare</i>	60	Vadas 1994
	Riverweed darter	<i>Etheostoma podostemone</i>	37	Vadas 1994
	Greenside darter	<i>Etheostoma blennioides</i>	30	Temple 1997
	Redline darter	<i>Etheostoma rufilineatum</i>	40	Temple 1997
	Banded Darter	<i>Etheostoma zonale</i>	10	Temple 1997
	Snubnose darter	<i>Etheostoma simoterum</i>	7	Temple 1997
Minnows				
	Central stoneroller	<i>Campostoma anomalum</i>	17	Vadas 1994
	Whitetail shiner	<i>Cyprinella galactura</i>	6	Temple 1997
	Blotched chub	<i>Erimystax insignis</i>	11	Temple 1997
	Bigeye chub	<i>Hybopsis amblops</i>	11	Temple 1997
	Crescent shiner	<i>Luxilus cerasinus</i>	37	Vadas 1994
	White shiner	<i>Luxilus albeolus</i>	23	Vadas 1994
	Striped shiner	<i>Luxilus chrysocephalus</i>	11	Temple 1997
	Warpaint shiner	<i>Luxilus coccogenis</i>	14	Temple 1997
	Bluehead chub	<i>Nocomis leptcephalus</i>	31	Vadas 1994
	River chub	<i>Nocomis micropogon</i>	10	Temple 1997
	Tennessee shiner	<i>Notropis leuciodus</i>	10	Temple 1997
	Telescope shiner	<i>Notropis telescopus</i>	11	Temple 1997
	Mimic shiner	<i>Notropis volucellus</i>	12	Vadas 1994
	Swallowtail shiner	<i>Notropis procne</i>	14	Vadas 1994
	Spottail shiner	<i>Notropis hudsonius</i>	16	Vadas 1994
	Stargazing minnow	<i>Phenacobius uranops</i>	5	Temple 1997
	Mt. redbelly dace	<i>Phoxinus oreas</i>	43	Vadas 1994
	Bluntnose minnow	<i>Pimephales notatus</i>	12	Vadas 1994
	East. blacknose dace	<i>Rhinichthys atratulus atratulus</i>	45	Vadas 1994
Suckers				
	Torrent sucker	<i>Thoburnia rathoeca</i>	34	Vadas 1994
	Black jumprock	<i>Scartomyzon cervinum</i>	25	Vadas 1994
	White sucker	<i>Catostomus commersoni</i>	26	Vadas 1994
	Northern hog sucker	<i>Hypentelium nigricans</i>	7	Vadas 1994
	Roanoke hog sucker	<i>Hypentelium roanokense</i>	17	Vadas 1994

Table G.2. Correlation Coefficient Matrix for Morphology Traits of Darters. Species and sample sizes are as follows: *Percina aurantiaca* (10), *Percina roanoka* (9), *Percina evides* (13), *Percina rex* (14), *Etheostoma flabellare* (60), *Etheostoma podostemone* (37), *Etheostoma blennioides* (30), *Etheostoma rufilineatum* (40), *Etheostoma zonale* (10), and *Etheostoma simoterum* (7).

	ACF1	CFD	MBD	TLDF	MDFS	MDFSMBD	MBW
ACF1	1.0000	-.2440	-.2259	0.2162	-.0079	0.1860	-.1828
CFD	-.2440	1.0000	-.1529	-.2569	-.4053	-.1909	-.5773
MBD	-.2259	-.1529	1.0000	-.3177	0.2617	-.6100	0.3508
TLDF	0.2162	-.2569	-.3177	1.0000	-.0189	0.2720	0.0615
MDFS	-.0079	-.4053	0.2617	-.0189	1.0000	0.6038	0.1934
MDFSMBD	0.1860	-.1909	-.6100	0.2720	0.6038	1.0000	-.1453
MBW	-.1828	-.5773	0.3508	0.0615	0.1934	-.1453	1.0000
CPD	-.1320	-.2372	0.7331	-.2537	-.1228	-.7146	0.7049
CPW	-.0405	-.0902	0.4503	-.2368	0.0660	-.3262	0.3850
HD	0.0174	-.3878	0.6532	-.5403	-.0240	-.5744	0.3946
TRUNK	-.1046	0.1830	0.0073	0.5405	-.2527	-.1759	0.1456
PFW	0.1676	-.1286	0.0205	-.2472	-.0458	-.0469	-.3384
PFL	0.3468	-.2355	-.0515	-.2696	0.2269	0.2320	0.1118
PECAREA	0.0709	0.0242	-.7892	0.7102	-.3431	0.3805	-.3351
PECASP	0.2274	-.2498	0.4868	-.5427	0.4056	-.0740	0.3645
EYELOC	-.3626	-.0864	0.4310	-.2041	-.1663	-.5001	0.7862
PECPEL	-.5530	-.4153	0.6481	0.0944	0.3108	-.2774	0.6579
EYESIZ	0.2373	-.2738	0.1774	-.6720	0.1792	-.0154	0.0707
CPL	0.0549	0.2533	-.1195	-.5149	0.2030	0.2461	-.3922
CFL	0.5858	-.4691	0.1041	-.2215	0.1026	-.0142	0.4391
EYESIZHD	0.2937	-.1069	-.2405	-.4842	0.3056	0.4418	-.2284
CFDMBD	-.0975	0.8144	-.6932	-.0244	-.4548	0.2081	-.5933
MBDMBW	-.0851	0.1638	0.8078	-.3672	0.1714	-.5177	-.2656
CFAREA	0.0052	0.4084	-.6657	0.5065	-.4637	0.1735	-.3025
CFASP	0.3465	-.8779	0.2081	0.0295	0.3339	0.0838	0.7126
CFASP2	-.4986	0.8543	-.1177	0.0133	-.3186	-.1474	-.5138
CFASP22	-.2420	0.4924	0.5495	-.6492	0.1310	-.3342	-.2914
ADFAF	-.1837	-.4330	0.2268	0.7567	0.2310	0.0147	0.4735
PDFAF	-.0791	-.2767	0.9022	-.1271	0.0991	-.6592	0.5723
JMAX	-.2710	-.1771	0.4692	0.1069	-.1264	-.4851	0.6109
PNERDF	-.1184	0.0574	0.6341	-.2486	-.2845	-.7596	0.3529
AFVMCF	0.2925	0.6503	-.2618	-.2740	-.3784	-.0868	-.7586
PECPEL	-.5530	-.4153	0.6481	0.0944	0.3108	-.2774	0.6579
PNERPEC	0.1714	-.3085	0.8312	-.3532	0.0738	-.6378	0.2599
ADFPEL	-.1582	-.4951	0.6975	-.5035	0.4551	-.2301	0.4400
VMCFDMCF	0.0196	0.1859	0.5187	0.1238	-.5127	-.8288	0.2349
PNERPEL	-.3227	-.1524	0.9378	-.0615	0.2879	-.5269	0.2861
MAXPEC	0.1366	-.5383	0.6245	0.0271	-.0334	-.5383	0.5250
PELAF	0.0715	-.6394	0.1304	0.3658	-.1082	-.2092	0.8484
CPINDEX	-.0668	-.2013	0.4916	-.1613	-.1653	-.5473	0.5207

Table G.2 *continued*. Correlation coefficient matrix for morphology traits of darters

	CPD	CPW	HD	TRUNK	PFW	PFL	PECAREA
ACF1	-.1320	-.0405	0.0174	-.1046	0.1676	0.3468	0.0709
CFD	-.2372	-.0902	-.3878	0.1830	-.1286	-.2355	0.0242
MBD	0.7331	0.4503	0.6532	0.0073	0.0205	-.0515	-.7892
TLDF	-.2537	-.2368	-.5403	0.5405	-.2472	-.2696	0.7102
MDFS	-.1228	0.0660	-.0240	-.2527	-.0458	0.2269	-.3431
MDFSMBD	-.7146	-.3262	-.5744	-.1759	-.0469	0.2320	0.3805
MBW	0.7049	0.3850	0.3946	0.1456	-.3384	0.1118	-.3351
CPD	1.0000	0.3295	0.6566	0.1509	-.0808	0.0700	-.6494
CPW	0.3295	1.0000	0.4916	-.0718	-.3388	-.1872	-.4906
HD	0.6566	0.4916	1.0000	-.1933	0.3581	0.3986	-.6801
TRUNK	0.1509	-.0718	-.1933	1.0000	0.0968	0.0035	0.2252
PFW	-.0808	-.3388	0.3581	0.0968	1.0000	0.5182	-.0824
PFL	0.0700	-.1872	0.3986	0.0035	0.5182	1.0000	-.2691
PECAREA	-.6494	-.4906	-.6801	0.2252	-.0824	-.2691	1.0000
PECASP	0.4940	0.2258	0.6745	-.1406	0.3018	0.7789	-.7989
EYELOC	0.8658	0.1817	0.4040	0.3082	-.1944	0.1289	-.4570
PECPEL	0.6257	0.0915	0.3372	0.3406	0.0178	-.0563	-.3354
EYESIZ	0.1428	0.2689	0.7328	-.3546	0.5989	0.7138	-.5495
CPL	-.3837	0.1065	0.0180	-.7808	-.2079	0.1277	-.1590
CFL	0.4713	0.0389	0.4448	-.0910	0.2958	0.5792	-.4276
EYESIZHD	-.3371	-.0175	0.2440	-.2883	0.6342	0.6791	-.2256
CFDMBD	-.5872	-.3116	-.6440	0.1142	-.1290	-.1396	0.4746
MBDMBW	0.3027	0.2259	0.4415	-.1286	0.2359	-.1089	-.6033
CFAREA	-.4616	-.2598	-.8064	0.1261	-.5249	-.6071	0.7606
CFASP	0.4932	0.0864	0.4809	-.1534	0.1344	0.4258	-.2867
CFASP2	-.3409	-.0384	-.4788	0.2073	-.3251	-.4937	0.2497
CFASP22	0.1732	0.1880	0.3963	0.0290	0.3645	0.2779	-.6726
ADFAF	0.2197	-.0096	-.2286	0.3895	-.4366	-.4130	0.2636
PDFAF	0.9057	0.3684	0.6536	0.2545	0.0330	0.0640	-.6924
JMAX	0.6679	0.3831	0.2927	0.5809	0.0075	-.2386	-.3017
PNERDF	0.7773	0.3840	0.4287	0.2484	0.0341	-.3041	-.5507
AFVMCF	-.3590	-.2970	-.1471	-.2291	0.1240	0.1803	0.1048
PECPEL	0.6257	0.0915	0.3372	0.3406	0.0178	-.0563	-.3354
PNERPEC	0.6641	0.5418	0.7603	-.3021	0.0344	-.0587	-.7000
ADFPEL	0.5260	0.4422	0.6352	-.5029	0.0563	-.0531	-.7238
VMCFDMCF	0.6856	0.2560	0.3441	0.6160	-.0156	-.1140	-.2508
PNERPEL	0.6212	0.2572	0.4500	0.2102	0.0512	-.1511	-.5757
MAXPEC	0.7565	0.1899	0.7007	0.3424	0.4103	0.2633	-.4214
PELAF	0.5479	0.3882	0.2762	0.1696	-.3882	-.1174	0.0267
CPINDEX	0.8559	-.2015	0.4209	0.1612	0.1038	0.2056	-.4207

Table G.2 *continued*. Correlation coefficient matrix for morphology traits of darters

	PECASP	EYELOC	PECPEL	EYESIZ	CPL	CFL	EYESIZHD
ACF1	0.2274	-.3626	-.5530	0.2373	0.0549	0.5858	0.2937
CFD	-.2498	-.0864	-.4153	-.2738	0.2533	-.4691	-.1069
MBD	0.4868	0.4310	0.6481	0.1774	-.1195	0.1041	-.2405
TLDF	-.5427	-.2041	0.0944	-.6720	-.5149	-.2215	-.4842
MDFS	0.4056	-.1663	0.3108	0.1792	0.2030	0.1026	0.3056
MDFSMBD	-.0740	-.5001	-.2774	-.0154	0.2461	-.0142	0.4418
MBW	0.3645	0.7862	0.6579	0.0707	-.3922	0.4391	-.2284
CPD	0.4940	0.8658	0.6257	0.1428	-.3837	0.4713	-.3371
CPW	0.2258	0.1817	0.0915	0.2689	0.1065	0.0389	-.0175
HD	0.6745	0.4040	0.3372	0.7328	0.0180	0.4448	0.2440
TRUNK	-.1406	0.3082	0.3406	-.3546	-.7808	-.0910	-.2883
PFW	0.3018	-.1944	0.0178	0.5989	-.2079	0.2958	0.6342
PFL	0.7789	0.1289	-.0563	0.7138	0.1277	0.5792	0.6791
PECAREA	-.7989	-.4570	-.3354	-.5495	-.1590	-.4276	-.2256
PECASP	1.0000	0.3920	0.2085	0.7551	0.1496	0.6794	0.5131
EYELOC	0.3920	1.0000	0.6222	0.0262	-.4208	0.3691	-.3122
PECPEL	0.2085	0.6222	1.0000	-.0968	-.5618	0.0233	-.3433
EYESIZ	0.7551	0.0262	-.0968	1.0000	0.2800	0.5645	0.8326
CPL	0.1496	-.4208	-.5618	0.2800	1.0000	-.2141	0.3078
CFL	0.6794	0.3691	0.0233	0.5645	-.2141	1.0000	0.4194
EYESIZHD	0.5131	-.3122	-.3433	0.8326	0.3078	0.4194	1.0000
CFDMBD	-.4643	-.2824	-.6599	-.2961	0.2744	-.4241	0.0537
MBDMBW	0.2857	-.0760	0.2394	0.1614	0.1520	-.1495	-.0866
CFAREA	-.8509	-.2642	-.4633	-.7718	-.0145	-.4582	-.4883
CFASP	0.5328	0.3839	0.3838	0.4109	-.2872	0.8045	0.1960
CFASP2	-.5360	-.1825	-.2118	-.5375	0.2347	-.8485	-.3867
CFASP22	0.5150	0.0725	0.0914	0.4255	0.2626	-.0981	0.3083
ADFAF	-.3299	0.2048	0.6267	-.6644	-.5331	-.2188	-.7193
PDFAF	0.5215	0.6625	0.7142	0.1305	-.4256	0.3569	-.3132
JMAX	0.0692	0.6566	0.6760	-.0856	-.8127	0.2363	-.2980
PNERDF	0.1655	0.5928	0.4254	0.0150	-.5141	0.3143	-.3007
AFVMCF	-.0222	-.4055	-.7369	0.0629	0.5959	-.1926	0.1461
PECPEL	0.2085	0.6222	1.0000	-.0968	-.5618	0.0233	-.3433
PNERPEC	0.4442	0.2252	0.2822	0.3364	0.0505	0.3188	-.1322
ADFPEL	0.4544	0.2628	0.4853	0.4304	0.0768	0.3368	0.1198
VMCFDMCF	0.0991	0.5423	0.3241	-.1759	-.5471	0.1070	-.5144
PNERPEL	0.2897	0.3619	0.7700	-.0528	-.3046	-.0720	-.3760
MAXPEC	0.4680	0.5197	0.6283	0.3181	-.6433	0.5529	-.0576
PELAF	0.0112	0.5428	0.4114	-.1130	-.4746	0.3640	-.3960
CPINDEX	0.4190	0.7953	0.5547	0.0369	-.4288	0.5188	-.3021

Table G.2 *continued*. Correlation coefficient matrix for morphology traits of darters

	CFDMBD	MBDMBW	CFAREA	CFASP	CFASP2	CFASP22	ADFAF
ACF1	-.0975	-.0851	0.0052	0.3465	-.4986	-.2420	-.1837
CFD	0.8144	0.1638	0.4084	-.8779	0.8543	0.4924	-.4330
MBD	-.6932	0.8078	-.6657	0.2081	-.1177	0.5495	0.2268
TLDF	-.0244	-.3672	0.5065	0.0295	0.0133	-.6492	0.7567
MDFS	-.4548	0.1714	-.4637	0.3339	-.3186	0.1310	0.2310
MDFSMBD	0.2081	-.5177	0.1735	0.0838	-.1474	-.3342	0.0147
MBW	-.5933	-.2656	-.3025	0.7126	-.5138	-.2914	0.4735
CPD	-.5872	0.3027	-.4616	0.4932	-.3409	0.1732	0.2197
CPW	-.3116	0.2259	-.2598	0.0864	-.0384	0.1880	-.0096
HD	-.6440	0.4415	-.8064	0.4809	-.4788	0.3963	-.2286
TRUNK	0.1142	-.1286	0.1261	-.1534	0.2073	0.0290	0.3895
PFW	-.1290	0.2359	-.5249	0.1344	-.3251	0.3645	-.4366
PFL	-.1396	-.1089	-.6071	0.4258	-.4937	0.2779	-.4130
PECAREA	0.4746	-.6033	0.7606	-.2867	0.2497	-.6726	0.2636
PECASP	-.4643	0.2857	-.8509	0.5328	-.5360	0.5150	-.3299
EYELOC	-.2824	-.0760	-.2642	0.3839	-.1825	0.0725	0.2048
PECPEL	-.6599	0.2394	-.4633	0.3838	-.2118	0.0914	0.6267
EYESIZ	-.2961	0.1614	-.7718	0.4109	-.5375	0.4255	-.6644
CPL	0.2744	0.1520	-.0145	-.2872	0.2347	0.2626	-.5331
CFL	-.4241	-.1495	-.4582	0.8045	-.8485	-.0981	-.2188
EYESIZHD	0.0537	-.0866	-.4883	0.1960	-.3867	0.3083	-.7193
CFDMBD	1.0000	-.3706	0.6813	-.7618	0.7042	0.0370	-.4476
MBDMBW	-.3706	1.0000	-.5105	-.2007	0.1641	0.7289	-.0657
CFAREA	0.6813	-.5105	1.0000	-.4993	0.5249	-.5766	0.1871
CFASP	-.7618	-.2007	-.4993	1.0000	-.9614	-.3688	0.2334
CFASP2	0.7042	0.1641	0.5249	-.9614	1.0000	0.3195	-.0625
CFASP22	0.0370	0.7289	-.5766	-.3688	0.3195	1.0000	-.4859
ADFAF	-.4476	-.0657	0.1871	0.2334	-.0625	-.4859	1.0000
PDFAF	-.7308	0.5625	-.6048	0.4281	-.3109	0.3328	0.3438
JMAX	-.4041	0.0682	-.2023	0.2914	-.1867	0.0046	0.3975
PNERDF	-.3409	0.4070	-.2292	0.1660	-.1087	0.2402	0.0795
AFVMCF	0.6136	0.2079	0.2250	-.5793	0.4588	0.3641	-.6220
PECPEL	-.6599	0.2394	-.4633	0.3838	-.2118	0.0914	0.6267
PNERPEC	-.7175	0.7151	-.5657	0.3626	-.3478	0.3067	0.0371
ADFPEL	-.7578	0.4658	-.6523	0.5305	-.4935	0.1990	0.0412
VMCFMCF	-.1785	0.3566	-.0832	-.0365	0.1167	0.2355	0.2312
PNERPEL	-.6618	0.7767	-.5495	0.1171	-.0161	0.4671	0.4476
MAXPEC	-.7683	0.3147	-.6289	0.6355	-.6064	0.0994	0.2716
PELAF	-.5226	-.3885	0.0205	0.6598	-.5074	-.6265	0.5682
CPINDEX	-.4300	0.1691	-.3399	0.4907	-.3663	0.0678	0.1896

Table G.2 *continued.* Correlation coefficient matrix for morphology traits of darters

	PDFAF	JMAX	PNERDF	AFVMCF	PECPEL	PNERPEC	ADFPPEL
ACF1	-.0791	-.2710	-.1184	0.2925	-.5530	0.1714	-.1582
CFD	-.2767	-.1771	0.0574	0.6503	-.4153	-.3085	-.4951
MBD	0.9022	0.4692	0.6341	-.2618	0.6481	0.8312	0.6975
TLDF	-.1271	0.1069	-.2486	-.2740	0.0944	-.3532	-.5035
MDFS	0.0991	-.1264	-.2845	-.3784	0.3108	0.0738	0.4551
MDFSMBD	-.6592	-.4851	-.7596	-.0868	-.2774	-.6378	-.2301
MBW	0.5723	0.6109	0.3529	-.7586	0.6579	0.2599	0.4400
CPD	0.9057	0.6679	0.7773	-.3590	0.6257	0.6641	0.5260
CPW	0.3684	0.3831	0.3840	-.2970	0.0915	0.5418	0.4422
HD	0.6536	0.2927	0.4287	-.1471	0.3372	0.7603	0.6352
TRUNK	0.2545	0.5809	0.2484	-.2291	0.3406	-.3021	-.5029
PFW	0.0330	0.0075	0.0341	0.1240	0.0178	0.0344	0.0563
PFL	0.0640	-.2386	-.3041	0.1803	-.0563	-.0587	-.0531
PECAREA	-.6924	-.3017	-.5507	0.1048	-.3354	-.7000	-.7238
PECASP	0.5215	0.0692	0.1655	-.0222	0.2085	0.4442	0.4544
EYELOC	0.6625	0.6566	0.5928	-.4055	0.6222	0.2252	0.2628
PECPEL	0.7142	0.6760	0.4254	-.7369	1.0000	0.2822	0.4853
EYESIZ	0.1305	-.0856	0.0150	0.0629	-.0968	0.3364	0.4304
CPL	-.4256	-.8127	-.5141	0.5959	-.5618	0.0505	0.0768
CFL	0.3569	0.2363	0.3143	-.1926	0.0233	0.3188	0.3368
EYESIZHD	-.3132	-.2980	-.3007	0.1461	-.3433	-.1322	0.1198
CFDMBD	-.7308	-.4041	-.3409	0.6136	-.6599	-.7175	-.7578
MBDMBW	0.5625	0.0682	0.4070	0.2079	0.2394	0.7151	0.4658
CFAREA	-.6048	-.2023	-.2292	0.2250	-.4633	-.5657	-.6523
CFASP	0.4281	0.2914	0.1660	-.5793	0.3838	0.3626	0.5305
CFASP2	-.3109	-.1867	-.1087	0.4588	-.2118	-.3478	-.4935
CFASP22	0.3328	0.0046	0.2402	0.3641	0.0914	0.3067	0.1990
ADFAF	0.3438	0.3975	0.0795	-.6220	0.6267	0.0371	0.0412
PDFAF	1.0000	0.6702	0.7414	-.3859	0.7142	0.7570	0.5613
JMAX	0.6702	1.0000	0.8117	-.7081	0.6760	0.2848	0.3177
PNERDF	0.7414	0.8117	1.0000	-.3143	0.4254	0.6031	0.4654
AFVMCF	-.3859	-.7081	-.3143	1.0000	-.7369	-.1085	-.4869
PECPEL	0.7142	0.6760	0.4254	-.7369	1.0000	0.2822	0.4853
PNERPEC	0.7570	0.2848	0.6031	-.1085	0.2822	1.0000	0.7418
ADFPPEL	0.5613	0.3177	0.4654	-.4869	0.4853	0.7418	1.0000
VMCFDMCF	0.7143	0.6254	0.7143	-.0083	0.3241	0.4372	-.0695
PNRPEL	0.8562	0.5096	0.5586	-.3399	0.7700	0.6589	0.5476
MAXPEC	0.8357	0.6790	0.6258	-.4637	0.6283	0.6079	0.4414
PELAF	0.4069	0.5554	0.3138	-.6782	0.4114	0.2565	0.2400
CPINDEX	0.7221	0.4605	0.5918	-.1883	0.5547	0.3977	0.3089

Table G.2 *continued*. Correlation coefficient matrix for morphology traits of darters.

	VMCFDMCF	PNRPEL	MAXPEC	PELAF	CPINDEX
ACF1	0.0196	-.3227	0.1366	0.0715	-.0668
CFD	0.1859	-.1524	-.5383	-.6394	-.2013
MBD	0.5187	0.9378	0.6245	0.1304	0.4916
TLDF	0.1238	-.0615	0.0271	0.3658	-.1613
MDFS	-.5127	0.2879	-.0334	-.1082	-.1653
MDFSMBD	-.8288	-.5269	-.5383	-.2092	-.5473
MBW	0.2349	0.2861	0.5250	0.8484	0.5207
CPD	0.6856	0.6212	0.7565	0.5479	0.8559
CPW	0.2560	0.2572	0.1899	0.3882	-.2015
HD	0.3441	0.4500	0.7007	0.2762	0.4209
TRUNK	0.6160	0.2102	0.3424	0.1696	0.1612
PFW	-.0156	0.0512	0.4103	-.3882	0.1038
PFL	-.1140	-.1511	0.2633	-.1174	0.2056
PECAREA	-.2508	-.5757	-.4214	0.0267	-.4207
PECASP	0.0991	0.2897	0.4680	0.0112	0.4190
EYELOC	0.5423	0.3619	0.5197	0.5428	0.7953
PECPEL	0.3241	0.7700	0.6283	0.4114	0.5547
EYESIZ	-.1759	-.0528	0.3181	-.1130	0.0369
CPL	-.5471	-.3046	-.6433	-.4746	-.4288
CFL	0.1070	-.0720	0.5529	0.3640	0.5188
EYESIZHD	-.5144	-.3760	-.0576	-.3960	-.3021
CFDMBD	-.1785	-.6618	-.7683	-.5226	-.4300
MBDMBW	0.3566	0.7767	0.3147	-.3885	0.1691
CFAREA	-.0832	-.5495	-.6289	0.0205	-.3399
CFASP	-.0365	0.1171	0.6355	0.6598	0.4907
CFASP2	0.1167	-.0161	-.6064	-.5074	-.3663
CFASP22	0.2355	0.4671	0.0994	-.6265	0.0678
ADFAF	0.2312	0.4476	0.2716	0.5682	0.1896
PDFAF	0.7143	0.8562	0.8357	0.4069	0.7221
JMAX	0.6254	0.5096	0.6790	0.5554	0.4605
PNRDF	0.7143	0.5586	0.6258	0.3138	0.5918
AFVMCF	-.0083	-.3399	-.4637	-.6782	-.1883
PECPEL	0.3241	0.7700	0.6283	0.4114	0.5547
PNRPEC	0.4372	0.6589	0.6079	0.2565	0.3977
ADFPEL	-.0695	0.5476	0.4414	0.2400	0.3089
VMCFDMCF	1.0000	0.5271	0.6231	0.3114	0.5521
PNRPEL	0.5271	1.0000	0.6144	0.0931	0.4623
MAXPEC	0.6231	0.6144	1.0000	0.4978	0.6717
PELAF	0.3114	0.0931	0.4978	1.0000	0.3577
CPINDEX	0.5521	0.4623	0.6717	0.3577	1.0000

Table G.3. Correlation coefficient matrix for morphology traits of suckers. Species and samples sizes are as follows: *Thoburnia rathoeca* (34), *Scartomyzon cervinum* (25), *Catostomus commersoni* (26), *Hypentelium nigricans* (7), and *Hypentelium roanokense* (17).

	ACF1	CFD	MBD	TLDF	MDFS	MDFSMBD	MBW
ACF1	1.0000	0.1520	-.0971	-.0410	-.5106	-.1711	-.2821
CFD	0.1520	1.0000	0.1131	0.1609	-.0225	-.1182	0.0364
MBD	-.0971	0.1131	1.0000	0.6796	0.2433	-.9077	0.9071
TLDF	-.0410	0.1609	0.6796	1.0000	0.4491	-.5487	0.3772
MDFS	-.5106	-.0225	0.2433	0.4491	1.0000	0.1674	0.3073
MDFSMBD	-.1711	-.1182	-.9077	-.5487	0.1674	1.0000	-.7491
MBW	-.2821	0.0364	0.9071	0.3772	0.3073	-.7491	1.0000
CPD	0.1212	0.2178	0.9469	0.6728	0.0687	-.9546	0.7769
CPW	-.0862	-.1263	0.6264	0.1449	-.2089	-.7259	0.6022
HD	-.0478	0.1146	0.8731	0.6769	0.3489	-.7118	0.8159
TRUNK	0.5341	0.2382	-.4219	-.2718	-.7845	0.0731	-.6086
PFW	0.3082	0.9243	-.0038	-.1324	-.1632	-.0484	0.0085
PFL	0.5291	0.4130	-.5864	-.2622	-.0949	0.4929	-.6602
PECAREA	-.6860	0.4156	0.3839	0.0076	0.1891	-.2330	0.5621
PECASP	0.6740	-.3052	-.4003	0.0823	-.1190	0.2696	-.6145
EYELOC	-.4005	0.3047	-.3634	-.6166	0.1458	0.5003	-.0337
PECPEL	-.1729	-.0953	0.6857	0.0389	0.1750	-.5524	0.8926
EYESIZ	0.3476	-.0192	-.5698	0.1016	0.2146	0.6155	-.7102
CPL	-.4372	-.0338	-.6599	-.3889	-.0987	0.6219	-.5958
CFL	0.7273	-.0324	-.1731	0.2903	0.0671	0.1235	-.3991
EYESIZHD	0.2278	-.0633	-.8422	-.2173	0.0513	0.8294	-.9128
CFDMBD	0.0665	0.4257	-.8394	-.5536	-.1468	0.8019	-.7509
MBDMBW	0.3027	0.1981	0.6378	0.8768	0.0161	-.7109	0.2558
CFAREA	-.6995	0.2600	0.6209	0.3118	0.3163	-.4285	0.7272
CFASP	0.3876	-.6934	-.2085	0.1328	0.0913	0.1883	-.3302
CFASP2	-.4423	0.6930	0.2120	-.0656	-.0540	-.1754	0.3141
CFASP22	0.8005	0.4995	-.3651	-.0730	-.3147	0.1785	-.5410
ADFAF	-.8614	-.2526	0.3535	0.2051	0.7020	-.0226	0.5277
PDFAF	-.5322	0.1366	0.7897	0.5240	0.4643	-.5704	0.8104
JMAX	0.0406	0.1725	0.7361	0.7917	0.3123	-.6260	0.5733
PNERDF	0.3595	0.0175	0.6783	0.2493	-.1653	-.7682	0.6280
AFVMCF	0.5107	0.0877	-.6883	-.5349	-.4449	0.4527	-.7176
PECPEL	-.1729	-.0953	0.6857	0.0389	0.1750	-.5524	0.8926
PNERPEC	0.1861	0.2638	0.9086	0.7323	0.1441	-.8644	0.7488
ADFPEL	-.1991	0.2558	0.9305	0.6236	0.2415	-.8526	0.8414
VMCFDMCF	-.1666	0.0438	0.9572	0.6683	0.1848	-.9077	0.8369
PNERPEL	-.0917	-.0902	0.9191	0.5409	0.2455	-.8024	0.9080
MAXPEC	0.6845	0.0140	0.3472	0.4139	-.0275	-.3911	0.1834
PELAF	-.8490	-.4476	0.3272	0.1305	0.4611	-.0943	0.4808
CPINDEX	0.1020	0.3274	0.8592	0.7500	0.2998	-.7688	0.6980

Table G.3 *continued.* Correlation coefficient matrix for morphology traits of suckers.

	CPD	CPW	HD	TRUNK	PFW	PFL	PECAREA
ACF1	0.1212	-.0862	-.0478	0.5341	0.3082	0.5291	-.6860
CFD	0.2178	-.1263	0.1146	0.2382	0.9243	0.4130	0.4156
MBD	0.9469	0.6264	0.8731	-.4219	-.0038	-.5864	0.3839
TLDF	0.6728	0.1449	0.6769	-.2718	-.1324	-.2622	0.0076
MDFS	0.0687	-.2089	0.3489	-.7845	-.1632	-.0949	0.1891
MDFSMBD	-.9546	-.7259	-.7118	0.0731	-.0484	0.4929	-.2330
MBW	0.7769	0.6022	0.8159	-.6086	0.0085	-.6602	0.5621
CPD	1.0000	0.6186	0.7424	-.1966	0.1197	-.3662	0.2371
CPW	0.6186	1.0000	0.3100	-.0429	-.1132	-.5457	0.3866
HD	0.7424	0.3100	1.0000	-.5530	-.0221	-.5973	0.2884
TRUNK	-.1966	-.0429	-.5530	1.0000	0.3305	0.4647	-.3127
PFW	0.1197	-.1132	-.0221	0.3305	1.0000	0.5283	0.3242
PFL	-.3662	-.5457	-.5973	0.4647	0.5283	1.0000	-.4676
PECAREA	0.2371	0.3866	0.2884	-.3127	0.3242	-.4676	1.0000
PECASP	-.2497	-.4353	-.2768	0.2933	-.2708	0.5239	-.9778
EYELOC	-.4269	-.3419	-.3552	-.1086	0.4566	0.2537	0.4752
PECPEL	0.5407	0.4243	0.6653	-.5225	0.0248	-.5707	0.4297
EYESIZ	-.5279	-.7723	-.2652	0.1090	-.0841	0.5681	-.6846
CPL	-.6130	-.3789	-.7442	0.1990	-.1087	0.2599	0.0793
CFL	-.0424	-.4687	0.0272	0.1235	-.0361	0.5352	-.8532
EYESIZHD	-.7675	-.7933	-.6430	0.2970	-.0658	0.6859	-.6277
CFDMBD	-.7709	-.6686	-.7050	0.4232	0.4956	0.7080	-.0473
MBDMBW	0.7597	0.3225	0.5158	0.1129	-.0228	-.1167	-.1614
CFAREA	0.4340	0.4365	0.5835	-.5063	0.0814	-.7030	0.9170
CFASP	-.1984	-.2521	-.0509	-.0767	-.6673	0.0841	-.8761
CFASP2	0.1778	0.2525	0.0892	0.0471	0.6197	-.1475	0.9062
CFASP22	-.1118	-.4697	-.3165	0.5865	0.5892	0.8843	-.5510
ADFAF	0.0966	0.3168	0.3130	-.7379	-.3693	-.6175	0.6082
PDFAF	0.6109	0.6230	0.7022	-.5359	-.0210	-.6866	0.7237
JMAX	0.6996	0.0568	0.8646	-.4720	-.0542	-.3756	0.0735
PNERDF	0.7826	0.3643	0.5068	-.0902	0.1107	-.1549	-.0611
AFVMCF	-.4988	-.1216	-.7525	0.5570	0.2376	0.7155	-.4355
PECPEL	0.5407	0.4243	0.6653	-.5225	0.0248	-.5707	0.4297
PNERPEC	0.9001	0.3753	0.9238	-.3113	0.1310	-.4061	0.1774
ADFPEL	0.9164	0.6986	0.7065	-.3910	0.1071	-.4741	0.5248
VMCFDMCF	0.9385	0.7230	0.7355	-.3774	-.1053	-.5860	0.3821
PNERPEL	0.8247	0.4383	0.8864	-.5137	-.1404	-.6400	0.2580
MAXPEC	0.4121	-.1897	0.5594	-.0688	0.0289	0.0732	-.5422
PELAF	0.0808	0.4529	0.2409	-.5928	-.5543	-.7700	0.5521
CPINDEX	0.9040	0.2402	0.7707	-.3295	0.1968	-.1882	0.1558

Table G.3 *continued.* Correlation coefficient matrix for morphology traits of suckers.

	PECASP	EYELOC	PECPEL	EYESIZ	CPL	CFL	EYESIZHD
ACF1	0.6740	-.4005	-.1729	0.3476	-.4372	0.7273	0.2278
CFD	-.3052	0.3047	-.0953	-.0192	-.0338	-.0324	-.0633
MBD	-.4003	-.3634	0.6857	-.5698	-.6599	-.1731	-.8422
TLDF	0.0823	-.6166	0.0389	0.1016	-.3889	0.2903	-.2173
MDFS	-.1190	0.1458	0.1750	0.2146	-.0987	0.0671	0.0513
MDFSMBD	0.2696	0.5003	-.5524	0.6155	0.6219	0.1235	0.8294
MBW	-.6145	-.0337	0.8926	-.7102	-.5958	-.3991	-.9128
CPD	-.2497	-.4269	0.5407	-.5279	-.6130	-.0424	-.7675
CPW	-.4353	-.3419	0.4243	-.7723	-.3789	-.4687	-.7933
HD	-.2768	-.3552	0.6653	-.2652	-.7442	0.0272	-.6430
TRUNK	0.2933	-.1086	-.5225	0.1090	0.1990	0.1235	0.2970
PFW	-.2708	0.4566	0.0248	-.0841	-.1087	-.0361	-.0658
PFL	0.5239	0.2537	-.5707	0.5681	0.2599	0.5352	0.6859
PECAREA	-.9778	0.4752	0.4297	-.6846	0.0793	-.8532	-.6277
PECASP	1.0000	-.5117	-.5495	0.7872	-.0402	0.9116	0.7024
EYELOC	-.5117	1.0000	0.1851	-.1946	0.4151	-.4935	0.0549
PECPEL	-.5495	0.1851	1.0000	-.6742	-.6063	-.3847	-.8109
EYESIZ	0.7872	-.1946	-.6742	1.0000	0.1477	0.8040	0.9031
CPL	-.0402	0.4151	-.6063	0.1477	1.0000	-.2840	0.4859
CFL	0.9116	-.4935	-.3847	0.8040	-.2840	1.0000	0.5838
EYESIZHD	0.7024	0.0549	-.8109	0.9031	0.4859	0.5838	1.0000
CFDMBD	0.1145	0.5939	-.5991	0.4754	0.5914	0.0668	0.7049
MBDMBW	0.2251	-.7738	-.0649	0.0088	-.4166	0.3608	-.2525
CFAREA	-.8872	0.1810	0.5218	-.6389	-.0974	-.7218	-.7196
CFASP	0.8558	-.5869	-.2515	0.6206	-.1741	0.7367	0.4835
CFASP2	-.8633	0.5216	0.1940	-.5736	0.1866	-.7381	-.4613
CFASP22	0.6017	-.0224	-.4665	0.5427	-.0218	0.6853	0.5312
ADFAF	-.6006	0.1847	0.3909	-.3614	0.0042	-.5698	-.3851
PDFAF	-.6969	-.1012	0.5601	-.5711	-.4228	-.5080	-.7494
JMAX	-.0168	-.4518	0.3501	-.0167	-.4692	0.2644	-.3816
PNERDF	-.0446	-.1889	0.6508	-.4818	-.5433	0.0798	-.6227
AFVMCF	0.4799	0.0221	-.6537	0.3753	0.3189	0.3230	0.5684
PECPEL	-.5495	0.1851	1.0000	-.6742	-.6063	-.3847	-.8109
PNERPEC	-.1611	-.4626	0.5514	-.2916	-.7311	0.1368	-.6491
ADFPEL	-.5026	-.2646	0.5311	-.6315	-.4409	-.2960	-.8226
VMCFDMCF	-.3887	-.4220	0.5489	-.6186	-.4781	-.2377	-.8257
PNERPEL	-.3281	-.2609	0.8331	-.5188	-.6753	-.1259	-.7901
MAXPEC	0.5304	-.4929	0.2348	0.3251	-.6740	0.7396	-.0138
PELAF	-.5786	0.0471	0.3625	-.4673	0.0613	-.6568	-.4418
CPINDEX	-.1431	-.2773	0.4931	-.2725	-.5410	0.1433	-.5543

Table G.3 *continued.* Correlation coefficient matrix for morphology traits of suckers.

	CFDMBD	MBDMBW	CFAREA	CFASP	CFASP2	CFASP22	ADFAF
ACF1	0.0665	0.3027	-.6995	0.3876	-.4423	0.8005	-.8614
CFD	0.4257	0.1981	0.2600	-.6934	0.6930	0.4995	-.2526
MBD	-.8394	0.6378	0.6209	-.2085	0.2120	-.3651	0.3535
TLDF	-.5536	0.8768	0.3118	0.1328	-.0656	-.0730	0.2051
MDFS	-.1468	0.0161	0.3163	0.0913	-.0540	-.3147	0.7020
MDFSMBD	0.8019	-.7109	-.4285	0.1883	-.1754	0.1785	-.0226
MBW	-.7509	0.2558	0.7272	-.3302	0.3141	-.5410	0.5277
CPD	-.7709	0.7597	0.4340	-.1984	0.1778	-.1118	0.0966
CPW	-.6686	0.3225	0.4365	-.2521	0.2525	-.4697	0.3168
HD	-.7050	0.5158	0.5835	-.0509	0.0892	-.3165	0.3130
TRUNK	0.4232	0.1129	-.5063	-.0767	0.0471	0.5865	-.7379
PFW	0.4956	-.0228	0.0814	-.6673	0.6197	0.5892	-.3693
PFL	0.7080	-.1167	-.7030	0.0841	-.1475	0.8843	-.6175
PECAREA	-.0473	-.1614	0.9170	-.8761	0.9062	-.5510	0.6082
PECASP	0.1145	0.2251	-.8872	0.8558	-.8633	0.6017	-.6006
EYELOC	0.5939	-.7738	0.1810	-.5869	0.5216	-.0224	0.1847
PECPEL	-.5991	-.0649	0.5218	-.2515	0.1940	-.4665	0.3909
EYESIZ	0.4754	0.0088	-.6389	0.6206	-.5736	0.5427	-.3614
CPL	0.5914	-.4166	-.0974	-.1741	0.1866	-.0218	0.0042
CFL	0.0668	0.3608	-.7218	0.7367	-.7381	0.6853	-.5698
EYESIZHD	0.7049	-.2525	-.7196	0.4835	-.4613	0.5312	-.3851
CFDMBD	1.0000	-.5537	-.3513	-.2294	0.2248	0.5217	-.3574
MBDMBW	-.5537	1.0000	0.0854	0.1400	-.1039	0.1689	-.1607
CFAREA	-.3513	0.0854	1.0000	-.6685	0.7271	-.6891	0.6977
CFASP	-.2294	0.1400	-.6685	1.0000	-.9869	0.1293	-.2025
CFASP2	0.2248	-.1039	0.7271	-.9869	1.0000	-.1850	0.2581
CFASP22	0.5217	0.1689	-.6891	0.1293	-.1850	1.0000	-.8591
ADFAF	-.3574	-.1607	0.6977	-.2025	0.2581	-.8591	1.0000
PDFAF	-.5901	0.3166	0.8683	-.4234	0.4812	-.6635	0.7613
JMAX	-.5819	0.6666	0.4010	0.0738	-.0323	-.0806	0.0779
ENERDF	-.6270	0.4225	0.0594	-.0242	-.0765	0.0942	-.2211
AFVMCF	0.5876	-.2521	-.6803	0.1680	-.1919	0.5963	-.5525
PECPEL	-.5991	-.0649	0.5218	-.2515	0.1940	-.4665	0.3909
ENERPEC	-.6999	0.7257	0.4443	-.0884	0.1005	-.0619	0.0431
ADFPEL	-.7094	0.6082	0.6855	-.3897	0.3972	-.3460	0.3973
VMCFDMCF	-.8556	0.6736	0.6090	-.2070	0.2152	-.4150	0.3739
ENERPEL	-.8491	0.4499	0.5217	-.0544	0.0346	-.4066	0.3202
MAXPEC	-.3519	0.4805	-.3081	0.4941	-.5172	0.4296	-.4800
PELAF	-.4572	-.1453	0.6614	-.1341	0.1940	-.9656	0.9406
CPINDEX	-.6078	0.7149	0.3692	-.1433	0.1172	0.0407	0.0599

Table G.3 *continued.* Correlation coefficient matrix for morphology traits of suckers.

	PDFAF	JMAX	PNERDF	AFVMCF	PECPEL	PNERPEC	ADFPEL
ACF1	-0.5322	0.0406	0.3595	0.5107	-0.1729	0.1861	-0.1991
CFD	0.1366	0.1725	0.0175	0.0877	-0.0953	0.2638	0.2558
MBD	0.7897	0.7361	0.6783	-0.6883	0.6857	0.9086	0.9305
TLDf	0.5240	0.7917	0.2493	-0.5349	0.0389	0.7323	0.6236
MDFS	0.4643	0.3123	-0.1653	-0.4449	0.1750	0.1441	0.2415
MDFSMBD	-0.5704	-0.6260	-0.7682	0.4527	-0.5524	-0.8644	-0.8526
MBW	0.8104	0.5733	0.6280	-0.7176	0.8926	0.7488	0.8414
CPD	0.6109	0.6996	0.7826	-0.4988	0.5407	0.9001	0.9164
CPW	0.6230	0.0568	0.3643	-0.1216	0.4243	0.3753	0.6986
HD	0.7022	0.8646	0.5068	-0.7525	0.6653	0.9238	0.7065
TRUNK	-0.5359	-0.4720	-0.0902	0.5570	-0.5225	-0.3113	-0.3910
PFW	-0.0210	-0.0542	0.1107	0.2376	0.0248	0.1310	0.1071
PFL	-0.6866	-0.3756	-0.1549	0.7155	-0.5707	-0.4061	-0.4741
PECAREA	0.7237	0.0735	-0.0611	-0.4355	0.4297	0.1774	0.5248
PECASP	-0.6969	-0.0168	-0.0446	0.4799	-0.5495	-0.1611	-0.5026
EYELoc	-0.1012	-0.4518	-0.1889	0.0221	0.1851	-0.4626	-0.2646
PECPEL	0.5601	0.3501	0.6508	-0.6537	1.0000	0.5514	0.5311
EYESIZ	-0.5711	-0.0167	-0.4818	0.3753	-0.6742	-0.2916	-0.6315
CPL	-0.4228	-0.4692	-0.5433	0.3189	-0.6063	-0.7311	-0.4409
CFL	-0.5080	0.2644	0.0798	0.3230	-0.3847	0.1368	-0.2960
EYESIZHD	-0.7494	-0.3816	-0.6227	0.5684	-0.8109	-0.6491	-0.8226
CFDMBD	-0.5901	-0.5819	-0.6270	0.5876	-0.5991	-0.6999	-0.7094
MBDMBW	0.3166	0.6666	0.4225	-0.2521	-0.0649	0.7257	0.6082
CFAREA	0.8683	0.4010	0.0594	-0.6803	0.5218	0.4443	0.6855
CFASP	-0.4234	0.0738	-0.0242	0.1680	-0.2515	-0.0884	-0.3897
CFASP2	0.4812	-0.0323	-0.0765	-0.1919	0.1940	0.1005	0.3972
CFASP22	-0.6635	-0.0806	0.0942	0.5963	-0.4665	-0.0619	-0.3460
ADFAF	0.7613	0.0779	-0.2211	-0.5525	0.3909	0.0431	0.3973
PDFAF	1.0000	0.4273	0.1419	-0.6546	0.5601	0.5751	0.8075
JMAX	0.4273	1.0000	0.5045	-0.6348	0.3501	0.8903	0.6261
PNERDF	0.1419	0.5045	1.0000	-0.3571	0.6508	0.6887	0.5640
AFVMCF	-0.6546	-0.6348	-0.3571	1.0000	-0.6537	-0.5958	-0.5141
PECPEL	0.5601	0.3501	0.6508	-0.6537	1.0000	0.5514	0.5311
PNERPEC	0.5751	0.8903	0.6887	-0.5958	0.5514	1.0000	0.7897
ADFPEL	0.8075	0.6261	0.5640	-0.5141	0.5311	0.7897	1.0000
VMCFDMCF	0.7615	0.6675	0.6322	-0.5843	0.5489	0.8138	0.9651
PNERPEL	0.6364	0.7413	0.7626	-0.8096	0.8331	0.8572	0.7444
MAXPEC	-0.1586	0.6572	0.5807	-0.1869	0.2348	0.6466	0.1014
PELAF	0.7031	0.0022	-0.2037	-0.5321	0.3625	-0.0122	0.3512
CPINDEX	0.4879	0.8349	0.7570	-0.5916	0.4931	0.9022	0.7984

Table G.3 *continued*. Correlation coefficient matrix for morphology traits of suckers.

	VMCFDMCF	PNERPEL	MAXPEC	PELAF	CPINDEX
ACF1	-0.1666	-0.0917	0.6845	-0.8490	0.1020
CFD	0.0438	-0.0902	0.0140	-0.4476	0.3274
MBD	0.9572	0.9191	0.3472	0.3272	0.8592
TLDF	0.6683	0.5409	0.4139	0.1305	0.7500
MDFS	0.1848	0.2455	-0.0275	0.4611	0.2998
MDFSMBD	-0.9077	-0.8024	-0.3911	-0.0943	-0.7688
MBW	0.8369	0.9080	0.1834	0.4808	0.6980
CPD	0.9385	0.8247	0.4121	0.0808	0.9040
CPW	0.7230	0.4383	-0.1897	0.4529	0.2402
HD	0.7355	0.8864	0.5594	0.2409	0.7707
TRUNK	-0.3774	-0.5137	-0.0688	-0.5928	-0.3295
PFW	-0.1053	-0.1404	0.0289	-0.5543	0.1968
PFL	-0.5860	-0.6400	0.0732	-0.7700	-0.1882
PECAREA	0.3821	0.2580	-0.5422	0.5521	0.1558
PECASP	-0.3887	-0.3281	0.5304	-0.5786	-0.1431
EYELOC	-0.4220	-0.2609	-0.4929	0.0471	-0.2773
PECPEL	0.5489	0.8331	0.2348	0.3625	0.4931
EYESIZ	-0.6186	-0.5188	0.3251	-0.4673	-0.2725
CPL	-0.4781	-0.6753	-0.6740	0.0613	-0.5410
CFL	-0.2377	-0.1259	0.7396	-0.6568	0.1433
EYESIZHD	-0.8257	-0.7901	-0.0138	-0.4418	-0.5543
CFDMBD	-0.8556	-0.8491	-0.3519	-0.4572	-0.6078
MBDMBW	0.6736	0.4499	0.4805	-0.1453	0.7149
CFAREA	0.6090	0.5217	-0.3081	0.6614	0.3692
CFASP	-0.2070	-0.0544	0.4941	-0.1341	-0.1433
CFASP2	0.2152	0.0346	-0.5172	0.1940	0.1172
CFASP22	-0.4150	-0.4066	0.4296	-0.9656	0.0407
ADFAF	0.3739	0.3202	-0.4800	0.9406	0.0599
PDFAF	0.7615	0.6364	-0.1586	0.7031	0.4879
JMAX	0.6675	0.7413	0.6572	0.0022	0.8349
PNERDF	0.6322	0.7626	0.5807	-0.2037	0.7570
AFVMCF	-0.5843	-0.8096	-0.1869	-0.5321	-0.5916
PECPEL	0.5489	0.8331	0.2348	0.3625	0.4931
PNERPEC	0.8138	0.8572	0.6466	-0.0122	0.9022
ADFPEL	0.9651	0.7444	0.1014	0.3512	0.7984
VMCFDMCF	1.0000	0.8230	0.1928	0.3914	0.7985
PNERPEL	0.8230	1.0000	0.4847	0.3115	0.8091
MAXPEC	0.1928	0.4847	1.0000	-0.5302	0.5556
PELAF	0.3914	0.3115	-0.5302	1.0000	-0.0567
CPINDEX	0.7985	0.8091	0.5556	-0.0567	1.0000

Table G.4. Correlation matrix of morphology traits for benthic minnows. Species and sample sizes are as follows: *Campostoma anomalum* (17), *Erimystax insignis* (11), *Hybopsis amblops* (11), *Nocomis leptocephalus* (31), *Nocomis micropogon* (10), *Phenacobius uranops* (5), and *Rhinichthys atratulus atratulus* (45)

	ACF1	CFD	MBD	TLDF	MDFS	MDFSMBD	MBW
ACF1	1.0000	0.1520	-.0971	-.0410	-.5106	-.1711	-.2821
CFD	0.1520	1.0000	0.1131	0.1609	-.0225	-.1182	0.0364
MBD	-.0971	0.1131	1.0000	0.6796	0.2433	-.9077	0.9071
TLDF	-.0410	0.1609	0.6796	1.0000	0.4491	-.5487	0.3772
MDFS	-.5106	-.0225	0.2433	0.4491	1.0000	0.1674	0.3073
MDFSMBD	-.1711	-.1182	-.9077	-.5487	0.1674	1.0000	-.7491
MBW	-.2821	0.0364	0.9071	0.3772	0.3073	-.7491	1.0000
CPD	0.1212	0.2178	0.9469	0.6728	0.0687	-.9546	0.7769
CPW	-.0862	-.1263	0.6264	0.1449	-.2089	-.7259	0.6022
HD	-.0478	0.1146	0.8731	0.6769	0.3489	-.7118	0.8159
TRUNK	0.5341	0.2382	-.4219	-.2718	-.7845	0.0731	-.6086
PFW	0.3082	0.9243	-.0038	-.1324	-.1632	-.0484	0.0085
PFL	0.5291	0.4130	-.5864	-.2622	-.0949	0.4929	-.6602
PECAREA	-.6860	0.4156	0.3839	0.0076	0.1891	-.2330	0.5621
PECASP	0.6740	-.3052	-.4003	0.0823	-.1190	0.2696	-.6145
EYELOC	-.4005	0.3047	-.3634	-.6166	0.1458	0.5003	-.0337
PECPEL	-.1729	-.0953	0.6857	0.0389	0.1750	-.5524	0.8926
EYESIZ	0.3476	-.0192	-.5698	0.1016	0.2146	0.6155	-.7102
CPL	-.4372	-.0338	-.6599	-.3889	-.0987	0.6219	-.5958
CFL	0.7273	-.0324	-.1731	0.2903	0.0671	0.1235	-.3991
EYESIZHD	0.2278	-.0633	-.8422	-.2173	0.0513	0.8294	-.9128
CFDMBD	0.0665	0.4257	-.8394	-.5536	-.1468	0.8019	-.7509
MBDMBW	0.3027	0.1981	0.6378	0.8768	0.0161	-.7109	0.2558
CFAREA	-.6995	0.2600	0.6209	0.3118	0.3163	-.4285	0.7272
CFASP	0.3876	-.6934	-.2085	0.1328	0.0913	0.1883	-.3302
CFASP2	-.4423	0.6930	0.2120	-.0656	-.0540	-.1754	0.3141
CFASP22	0.8005	0.4995	-.3651	-.0730	-.3147	0.1785	-.5410
ADFAF	-.8614	-.2526	0.3535	0.2051	0.7020	-.0226	0.5277
PDFAF	-.5322	0.1366	0.7897	0.5240	0.4643	-.5704	0.8104
JMAX	0.0406	0.1725	0.7361	0.7917	0.3123	-.6260	0.5733
PNERDF	0.3595	0.0175	0.6783	0.2493	-.1653	-.7682	0.6280
AFVMCF	0.5107	0.0877	-.6883	-.5349	-.4449	0.4527	-.7176
PECPEL	-.1729	-.0953	0.6857	0.0389	0.1750	-.5524	0.8926
PNERPEC	0.1861	0.2638	0.9086	0.7323	0.1441	-.8644	0.7488
ADFPEL	-.1991	0.2558	0.9305	0.6236	0.2415	-.8526	0.8414
VMCFDMCF	-.1666	0.0438	0.9572	0.6683	0.1848	-.9077	0.8369
PNERPEL	-.0917	-.0902	0.9191	0.5409	0.2455	-.8024	0.9080
MAXPEC	0.6845	0.0140	0.3472	0.4139	-.0275	-.3911	0.1834
PELAF	-.8490	-.4476	0.3272	0.1305	0.4611	-.0943	0.4808
CPINDEX	0.1020	0.3274	0.8592	0.7500	0.2998	-.7688	0.6980

Table G.4 *continued.* Correlation matrix of morphology traits for benthic minnows

	CPD	CPW	HD	TRUNK	PFW	PFL	PECAREA
ACF1	0.1212	-.0862	-.0478	0.5341	0.3082	0.5291	-.6860
CFD	0.2178	-.1263	0.1146	0.2382	0.9243	0.4130	0.4156
MBD	0.9469	0.6264	0.8731	-.4219	-.0038	-.5864	0.3839
TLDF	0.6728	0.1449	0.6769	-.2718	-.1324	-.2622	0.0076
MDFS	0.0687	-.2089	0.3489	-.7845	-.1632	-.0949	0.1891
MDFSMBD	-.9546	-.7259	-.7118	0.0731	-.0484	0.4929	-.2330
MBW	0.7769	0.6022	0.8159	-.6086	0.0085	-.6602	0.5621
CPD	1.0000	0.6186	0.7424	-.1966	0.1197	-.3662	0.2371
CPW	0.6186	1.0000	0.3100	-.0429	-.1132	-.5457	0.3866
HD	0.7424	0.3100	1.0000	-.5530	-.0221	-.5973	0.2884
TRUNK	-.1966	-.0429	-.5530	1.0000	0.3305	0.4647	-.3127
PFW	0.1197	-.1132	-.0221	0.3305	1.0000	0.5283	0.3242
PFL	-.3662	-.5457	-.5973	0.4647	0.5283	1.0000	-.4676
PECAREA	0.2371	0.3866	0.2884	-.3127	0.3242	-.4676	1.0000
PECASP	-.2497	-.4353	-.2768	0.2933	-.2708	0.5239	-.9778
EYELOC	-.4269	-.3419	-.3552	-.1086	0.4566	0.2537	0.4752
PECPEL	0.5407	0.4243	0.6653	-.5225	0.0248	-.5707	0.4297
EYESIZ	-.5279	-.7723	-.2652	0.1090	-.0841	0.5681	-.6846
CPL	-.6130	-.3789	-.7442	0.1990	-.1087	0.2599	0.0793
CFL	-.0424	-.4687	0.0272	0.1235	-.0361	0.5352	-.8532
EYESIZHD	-.7675	-.7933	-.6430	0.2970	-.0658	0.6859	-.6277
CFDMBD	-.7709	-.6686	-.7050	0.4232	0.4956	0.7080	-.0473
MBDMBW	0.7597	0.3225	0.5158	0.1129	-.0228	-.1167	-.1614
CFAREA	0.4340	0.4365	0.5835	-.5063	0.0814	-.7030	0.9170
CFASP	-.1984	-.2521	-.0509	-.0767	-.6673	0.0841	-.8761
CFASP2	0.1778	0.2525	0.0892	0.0471	0.6197	-.1475	0.9062
CFASP22	-.1118	-.4697	-.3165	0.5865	0.5892	0.8843	-.5510
ADFAF	0.0966	0.3168	0.3130	-.7379	-.3693	-.6175	0.6082
PDFAF	0.6109	0.6230	0.7022	-.5359	-.0210	-.6866	0.7237
JMAX	0.6996	0.0568	0.8646	-.4720	-.0542	-.3756	0.0735
ENERDF	0.7826	0.3643	0.5068	-.0902	0.1107	-.1549	-.0611
AFVMCF	-.4988	-.1216	-.7525	0.5570	0.2376	0.7155	-.4355
PECPEL	0.5407	0.4243	0.6653	-.5225	0.0248	-.5707	0.4297
ENERPEC	0.9001	0.3753	0.9238	-.3113	0.1310	-.4061	0.1774
ADFPEL	0.9164	0.6986	0.7065	-.3910	0.1071	-.4741	0.5248
VMCFDMCF	0.9385	0.7230	0.7355	-.3774	-.1053	-.5860	0.3821
ENERPEL	0.8247	0.4383	0.8864	-.5137	-.1404	-.6400	0.2580
MAXPEC	0.4121	-.1897	0.5594	-.0688	0.0289	0.0732	-.5422
PELAF	0.0808	0.4529	0.2409	-.5928	-.5543	-.7700	0.5521
CPINDEX	0.9040	0.2402	0.7707	-.3295	0.1968	-.1882	0.1558

Table G.4 *continued*. Correlation coefficient matrix of morphology traits for benthic minnows

	PECASP	EYELOC	PECPEL	EYESIZ	CPL	CFL	EYESIZHD
ACF1	0.6740	-.4005	-.1729	0.3476	-.4372	0.7273	0.2278
CFD	-.3052	0.3047	-.0953	-.0192	-.0338	-.0324	-.0633
MBD	-.4003	-.3634	0.6857	-.5698	-.6599	-.1731	-.8422
TLDF	0.0823	-.6166	0.0389	0.1016	-.3889	0.2903	-.2173
MDFS	-.1190	0.1458	0.1750	0.2146	-.0987	0.0671	0.0513
MDFSMBD	0.2696	0.5003	-.5524	0.6155	0.6219	0.1235	0.8294
MBW	-.6145	-.0337	0.8926	-.7102	-.5958	-.3991	-.9128
CPD	-.2497	-.4269	0.5407	-.5279	-.6130	-.0424	-.7675
CPW	-.4353	-.3419	0.4243	-.7723	-.3789	-.4687	-.7933
HD	-.2768	-.3552	0.6653	-.2652	-.7442	0.0272	-.6430
TRUNK	0.2933	-.1086	-.5225	0.1090	0.1990	0.1235	0.2970
PFW	-.2708	0.4566	0.0248	-.0841	-.1087	-.0361	-.0658
PFL	0.5239	0.2537	-.5707	0.5681	0.2599	0.5352	0.6859
PECAREA	-.9778	0.4752	0.4297	-.6846	0.0793	-.8532	-.6277
PECASP	1.0000	-.5117	-.5495	0.7872	-.0402	0.9116	0.7024
EYELOC	-.5117	1.0000	0.1851	-.1946	0.4151	-.4935	0.0549
PECPEL	-.5495	0.1851	1.0000	-.6742	-.6063	-.3847	-.8109
EYESIZ	0.7872	-.1946	-.6742	1.0000	0.1477	0.8040	0.9031
CPL	-.0402	0.4151	-.6063	0.1477	1.0000	-.2840	0.4859
CFL	0.9116	-.4935	-.3847	0.8040	-.2840	1.0000	0.5838
EYESIZHD	0.7024	0.0549	-.8109	0.9031	0.4859	0.5838	1.0000
CFDMBD	0.1145	0.5939	-.5991	0.4754	0.5914	0.0668	0.7049
MBDMBW	0.2251	-.7738	-.0649	0.0088	-.4166	0.3608	-.2525
CFAREA	-.8872	0.1810	0.5218	-.6389	-.0974	-.7218	-.7196
CFASP	0.8558	-.5869	-.2515	0.6206	-.1741	0.7367	0.4835
CFASP2	-.8633	0.5216	0.1940	-.5736	0.1866	-.7381	-.4613
CFASP22	0.6017	-.0224	-.4665	0.5427	-.0218	0.6853	0.5312
ADFAF	-.6006	0.1847	0.3909	-.3614	0.0042	-.5698	-.3851
PDFAF	-.6969	-.1012	0.5601	-.5711	-.4228	-.5080	-.7494
JMAX	-.0168	-.4518	0.3501	-.0167	-.4692	0.2644	-.3816
PNERDF	-.0446	-.1889	0.6508	-.4818	-.5433	0.0798	-.6227
AFVMCF	0.4799	0.0221	-.6537	0.3753	0.3189	0.3230	0.5684
PECPEL	-.5495	0.1851	1.0000	-.6742	-.6063	-.3847	-.8109
PNERPEC	-.1611	-.4626	0.5514	-.2916	-.7311	0.1368	-.6491
ADFPEL	-.5026	-.2646	0.5311	-.6315	-.4409	-.2960	-.8226
VMCFDMCF	-.3887	-.4220	0.5489	-.6186	-.4781	-.2377	-.8257
PNERPEL	-.3281	-.2609	0.8331	-.5188	-.6753	-.1259	-.7901
MAXPEC	0.5304	-.4929	0.2348	0.3251	-.6740	0.7396	-.0138
PELAF	-.5786	0.0471	0.3625	-.4673	0.0613	-.6568	-.4418
CPINDEX	-.1431	-.2773	0.4931	-.2725	-.5410	0.1433	-.5543

Table G.4 *continued.* Correlation coefficient matrix of morphology traits for benthic minnows

	CFDMBD	MBDMBW	CFAREA	CFASP	CFASP2	CFASP22	ADFAF
ACF1	0.0665	0.3027	-.6995	0.3876	-.4423	0.8005	-.8614
CFD	0.4257	0.1981	0.2600	-.6934	0.6930	0.4995	-.2526
MBD	-.8394	0.6378	0.6209	-.2085	0.2120	-.3651	0.3535
TLDF	-.5536	0.8768	0.3118	0.1328	-.0656	-.0730	0.2051
MDFS	-.1468	0.0161	0.3163	0.0913	-.0540	-.3147	0.7020
MDFSMBD	0.8019	-.7109	-.4285	0.1883	-.1754	0.1785	-.0226
MBW	-.7509	0.2558	0.7272	-.3302	0.3141	-.5410	0.5277
CPD	-.7709	0.7597	0.4340	-.1984	0.1778	-.1118	0.0966
CPW	-.6686	0.3225	0.4365	-.2521	0.2525	-.4697	0.3168
HD	-.7050	0.5158	0.5835	-.0509	0.0892	-.3165	0.3130
TRUNK	0.4232	0.1129	-.5063	-.0767	0.0471	0.5865	-.7379
PFW	0.4956	-.0228	0.0814	-.6673	0.6197	0.5892	-.3693
PFL	0.7080	-.1167	-.7030	0.0841	-.1475	0.8843	-.6175
PECAREA	-.0473	-.1614	0.9170	-.8761	0.9062	-.5510	0.6082
PECASP	0.1145	0.2251	-.8872	0.8558	-.8633	0.6017	-.6006
EYELOC	0.5939	-.7738	0.1810	-.5869	0.5216	-.0224	0.1847
PECPEL	-.5991	-.0649	0.5218	-.2515	0.1940	-.4665	0.3909
EYESIZ	0.4754	0.0088	-.6389	0.6206	-.5736	0.5427	-.3614
CPL	0.5914	-.4166	-.0974	-.1741	0.1866	-.0218	0.0042
CFL	0.0668	0.3608	-.7218	0.7367	-.7381	0.6853	-.5698
EYESIZHD	0.7049	-.2525	-.7196	0.4835	-.4613	0.5312	-.3851
CFDMBD	1.0000	-.5537	-.3513	-.2294	0.2248	0.5217	-.3574
MBDMBW	-.5537	1.0000	0.0854	0.1400	-.1039	0.1689	-.1607
CFAREA	-.3513	0.0854	1.0000	-.6685	0.7271	-.6891	0.6977
CFASP	-.2294	0.1400	-.6685	1.0000	-.9869	0.1293	-.2025
CFASP2	0.2248	-.1039	0.7271	-.9869	1.0000	-.1850	0.2581
CFASP22	0.5217	0.1689	-.6891	0.1293	-.1850	1.0000	-.8591
ADFAF	-.3574	-.1607	0.6977	-.2025	0.2581	-.8591	1.0000
PDFAF	-.5901	0.3166	0.8683	-.4234	0.4812	-.6635	0.7613
JMAX	-.5819	0.6666	0.4010	0.0738	-.0323	-.0806	0.0779
ENERDF	-.6270	0.4225	0.0594	-.0242	-.0765	0.0942	-.2211
AFVMCF	0.5876	-.2521	-.6803	0.1680	-.1919	0.5963	-.5525
PECPEL	-.5991	-.0649	0.5218	-.2515	0.1940	-.4665	0.3909
ENERPEC	-.6999	0.7257	0.4443	-.0884	0.1005	-.0619	0.0431
ADFPEL	-.7094	0.6082	0.6855	-.3897	0.3972	-.3460	0.3973
VMCFDMCF	-.8556	0.6736	0.6090	-.2070	0.2152	-.4150	0.3739
ENERPEL	-.8491	0.4499	0.5217	-.0544	0.0346	-.4066	0.3202
MAXPEC	-.3519	0.4805	-.3081	0.4941	-.5172	0.4296	-.4800
PELAF	-.4572	-.1453	0.6614	-.1341	0.1940	-.9656	0.9406
CPINDEX	-.6078	0.7149	0.3692	-.1433	0.1172	0.0407	0.0599

Table G.4 *continued*. Correlation coefficient matrix of morphology traits for benthic minnows

	PDFAF	JMAX	PNERDF	AFVMCF	PECPEL	PNERPEC	ADFPEL
ACF1	-.5322	0.0406	0.3595	0.5107	-.1729	0.1861	-.1991
CFD	0.1366	0.1725	0.0175	0.0877	-.0953	0.2638	0.2558
MBD	0.7897	0.7361	0.6783	-.6883	0.6857	0.9086	0.9305
TLDF	0.5240	0.7917	0.2493	-.5349	0.0389	0.7323	0.6236
MDFS	0.4643	0.3123	-.1653	-.4449	0.1750	0.1441	0.2415
MDFSMBD	-.5704	-.6260	-.7682	0.4527	-.5524	-.8644	-.8526
MBW	0.8104	0.5733	0.6280	-.7176	0.8926	0.7488	0.8414
CPD	0.6109	0.6996	0.7826	-.4988	0.5407	0.9001	0.9164
CPW	0.6230	0.0568	0.3643	-.1216	0.4243	0.3753	0.6986
HD	0.7022	0.8646	0.5068	-.7525	0.6653	0.9238	0.7065
TRUNK	-.5359	-.4720	-.0902	0.5570	-.5225	-.3113	-.3910
PFW	-.0210	-.0542	0.1107	0.2376	0.0248	0.1310	0.1071
PFL	-.6866	-.3756	-.1549	0.7155	-.5707	-.4061	-.4741
PECAREA	0.7237	0.0735	-.0611	-.4355	0.4297	0.1774	0.5248
PECASP	-.6969	-.0168	-.0446	0.4799	-.5495	-.1611	-.5026
EYELC	-.1012	-.4518	-.1889	0.0221	0.1851	-.4626	-.2646
PECPEL	0.5601	0.3501	0.6508	-.6537	1.0000	0.5514	0.5311
EYESIZ	-.5711	-.0167	-.4818	0.3753	-.6742	-.2916	-.6315
CPL	-.4228	-.4692	-.5433	0.3189	-.6063	-.7311	-.4409
CFL	-.5080	0.2644	0.0798	0.3230	-.3847	0.1368	-.2960
EYESIZHD	-.7494	-.3816	-.6227	0.5684	-.8109	-.6491	-.8226
CFDMBD	-.5901	-.5819	-.6270	0.5876	-.5991	-.6999	-.7094
MBDMBW	0.3166	0.6666	0.4225	-.2521	-.0649	0.7257	0.6082
CFAREA	0.8683	0.4010	0.0594	-.6803	0.5218	0.4443	0.6855
CFASP	-.4234	0.0738	-.0242	0.1680	-.2515	-.0884	-.3897
CFASP2	0.4812	-.0323	-.0765	-.1919	0.1940	0.1005	0.3972
CFASP22	-.6635	-.0806	0.0942	0.5963	-.4665	-.0619	-.3460
ADFAF	0.7613	0.0779	-.2211	-.5525	0.3909	0.0431	0.3973
PDFAF	1.0000	0.4273	0.1419	-.6546	0.5601	0.5751	0.8075
JMAX	0.4273	1.0000	0.5045	-.6348	0.3501	0.8903	0.6261
PNERDF	0.1419	0.5045	1.0000	-.3571	0.6508	0.6887	0.5640
AFVMCF	-.6546	-.6348	-.3571	1.0000	-.6537	-.5958	-.5141
PECPEL	0.5601	0.3501	0.6508	-.6537	1.0000	0.5514	0.5311
PNERPEC	0.5751	0.8903	0.6887	-.5958	0.5514	1.0000	0.7897
ADFPEL	0.8075	0.6261	0.5640	-.5141	0.5311	0.7897	1.0000
VMCFDMCF	0.7615	0.6675	0.6322	-.5843	0.5489	0.8138	0.9651
PNERPEL	0.6364	0.7413	0.7626	-.8096	0.8331	0.8572	0.7444
MAXPEC	-.1586	0.6572	0.5807	-.1869	0.2348	0.6466	0.1014
PELAF	0.7031	0.0022	-.2037	-.5321	0.3625	-.0122	0.3512
CPINDEX	0.4879	0.8349	0.7570	-.5916	0.4931	0.9022	0.7984

Table G.4 *continued*. Correlation coefficient matrix of morphology traits for benthic minnows.

	VMCFDMCF	PNERPEL	MAXPEC	PELAF	CPINDEX
ACF1	-.1666	-.0917	0.6845	-.8490	0.1020
CFD	0.0438	-.0902	0.0140	-.4476	0.3274
MBD	0.9572	0.9191	0.3472	0.3272	0.8592
TLDF	0.6683	0.5409	0.4139	0.1305	0.7500
MDFS	0.1848	0.2455	-.0275	0.4611	0.2998
MDFSMBD	-.9077	-.8024	-.3911	-.0943	-.7688
MBW	0.8369	0.9080	0.1834	0.4808	0.6980
CPD	0.9385	0.8247	0.4121	0.0808	0.9040
CPW	0.7230	0.4383	-.1897	0.4529	0.2402
HD	0.7355	0.8864	0.5594	0.2409	0.7707
TRUNK	-.3774	-.5137	-.0688	-.5928	-.3295
PFW	-.1053	-.1404	0.0289	-.5543	0.1968
PFL	-.5860	-.6400	0.0732	-.7700	-.1882
PECAREA	0.3821	0.2580	-.5422	0.5521	0.1558
PECASP	-.3887	-.3281	0.5304	-.5786	-.1431
EYELOC	-.4220	-.2609	-.4929	0.0471	-.2773
PECPEL	0.5489	0.8331	0.2348	0.3625	0.4931
EYESIZ	-.6186	-.5188	0.3251	-.4673	-.2725
CPL	-.4781	-.6753	-.6740	0.0613	-.5410
CFL	-.2377	-.1259	0.7396	-.6568	0.1433
EYESIZHD	-.8257	-.7901	-.0138	-.4418	-.5543
CFDMBD	-.8556	-.8491	-.3519	-.4572	-.6078
MBDMBW	0.6736	0.4499	0.4805	-.1453	0.7149
CFAREA	0.6090	0.5217	-.3081	0.6614	0.3692
CFASP	-.2070	-.0544	0.4941	-.1341	-.1433
CFASP2	0.2152	0.0346	-.5172	0.1940	0.1172
CFASP22	-.4150	-.4066	0.4296	-.9656	0.0407
ADFAF	0.3739	0.3202	-.4800	0.9406	0.0599
PDFAF	0.7615	0.6364	-.1586	0.7031	0.4879
JMAX	0.6675	0.7413	0.6572	0.0022	0.8349
ENERDF	0.6322	0.7626	0.5807	-.2037	0.7570
AFVMCF	-.5843	-.8096	-.1869	-.5321	-.5916
PECPEL	0.5489	0.8331	0.2348	0.3625	0.4931
ENERPEC	0.8138	0.8572	0.6466	-.0122	0.9022
ADFPEL	0.9651	0.7444	0.1014	0.3512	0.7984
VMCFDMCF	1.0000	0.8230	0.1928	0.3914	0.7985
PNERPEL	0.8230	1.0000	0.4847	0.3115	0.8091
MAXPEC	0.1928	0.4847	1.0000	-.5302	0.5556
PELAF	0.3914	0.3115	-.5302	1.0000	-.0567
CPINDEX	0.7985	0.8091	0.5556	-.0567	1.0000

Table G.5. Correlation coefficient matrix for pelagic minnows. Species and sample sizes are as follows: *Cyprinella galactura* (6), *Luxilus cerasinus* (37), *Luxilus albeolus*, (23), *Luxilus chrysocephalus* (11), *Luxilus coccogenis* (14), *Nocomis micropogon* (10), *Notropis leuciodus* (10), *Notropis telescopus* (11), *Notropis volucellus* (12), *Notropis procne* (14), *Notropis hudsonius* (16), *Phoxinus oreas* (43), and *Pimephales notatus* (12).

	ACF1	CFD	MBD	TLDF	MDFS	MDFSMBD	MBW
ACF1	1.0000	0.0066	0.1077	-.0480	-.4196	-.5335	0.4502
CFD	0.0066	1.0000	0.6528	0.5717	0.5861	0.2878	-.1272
MBD	0.1077	0.6528	1.0000	0.3864	0.4776	-.0325	0.4440
TLDF	-.0480	0.5717	0.3864	1.0000	0.0845	-.1565	0.0637
MDFS	-.4196	0.5861	0.4776	0.0845	1.0000	0.8586	-.2352
MDFSMBD	-.5335	0.2878	-.0325	-.1565	0.8586	1.0000	-.5518
MBW	0.4502	-.1272	0.4440	0.0637	-.2352	-.5518	1.0000
CPD	0.3517	0.4436	0.7021	0.3067	0.4263	0.0576	0.6758
CPW	0.6014	-.1673	0.1740	-.0618	0.0304	-.1020	0.6204
HD	-.1722	0.6600	0.9242	0.3889	0.6588	0.2192	0.2350
TRUNK	0.0730	0.2027	-.3627	0.2569	-.1492	0.0448	-.1313
PFW	0.4088	0.2504	0.3974	0.0734	0.1746	-.0211	0.2904
PFL	-.0369	0.7557	0.5962	0.3856	0.7941	0.5616	-.1877
PECAREA	-.2347	0.8785	0.7170	0.5447	0.4930	0.1478	-.0399
PECASP	0.3629	-.3624	-.2984	-.3109	0.0169	0.1863	-.1086
EYELOC	-.1550	0.5972	0.4672	0.3627	0.1548	-.1356	0.1913
PECPEL	-.1248	-.1977	-.4793	0.3870	-.4868	-.2931	-.1473
EYESIZ	-.1102	-.1097	0.0952	-.2566	0.2792	0.3016	-.3836
CPL	-.0158	-.6900	-.5895	-.4325	-.4731	-.2212	0.0848
CFL	0.2691	0.6226	0.5451	0.3834	0.5090	0.2713	-.1322
EYESIZHD	0.0843	-.5643	-.5992	-.5008	-.2816	0.0576	-.4934
CFDMD	-.1431	0.4490	-.3807	0.2463	0.1527	0.3914	-.6863
MBDMBW	-.1346	0.8070	0.8517	0.4025	0.6703	0.2891	-.0874
CFAREA	-.2236	0.8985	0.6535	0.6034	0.4765	0.1612	-.1235
CFASP	0.1740	-.7182	-.3623	-.3644	-.2632	-.0840	0.0122
CFASP2	-.2192	0.7532	0.3457	0.3704	0.3223	0.1622	-.0880
CFASP22	0.4317	-.1526	-.2370	-.2131	0.0248	0.1664	0.0496
ADFAF	-.1695	0.6656	0.9014	0.5482	0.5227	0.0754	0.1588
PDFAF	-.1005	0.7476	0.9480	0.5255	0.5547	0.0915	0.2115
JMAX	-.4558	0.6005	0.2703	-.0566	0.5798	0.5362	-.5313
PNERDF	0.4350	-.0180	-.2237	-.0768	-.1750	-.1054	0.4025
AFVMCF	0.2184	-.2129	0.0025	-.4812	0.0205	0.0609	-.0710
PECPEL	-.1248	-.1977	-.4793	0.3870	-.4868	-.2931	-.1473
PNERPEC	-.0571	0.7229	0.9112	0.3977	0.7011	0.2714	0.2899
ADFPEL	0.0558	0.7015	0.9842	0.3910	0.5656	0.0759	0.3751
VMCFDMCF	-.0938	0.6307	0.8008	0.2351	0.4550	0.0529	0.3979
PNERPEL	0.0563	0.6980	0.8009	0.5832	0.2148	-.2133	0.2416
MAXPEC	0.5615	0.4438	0.7014	0.0913	0.3472	-.0312	0.6092
PELAF	0.2817	0.1595	0.4923	0.3585	-.0256	-.3167	0.4703
CPINDEX	-.0986	0.7625	0.7950	0.4315	0.5036	0.1188	0.3026

Table G.5 *continued.* Correlation coefficient matrix for pelagic minnows.

	CPD	CPW	HD	TRUNK	PFW	PFL	PECAREA
ACF1	0.3517	0.6014	-.1722	0.0730	0.4088	-.0369	-.2347
CFD	0.4436	-.1673	0.6600	0.2027	0.2504	0.7557	0.8785
MBD	0.7021	0.1740	0.9242	-.3627	0.3974	0.5962	0.7170
TLDF	0.3067	-.0618	0.3889	0.2569	0.0734	0.3856	0.5447
MDFS	0.4263	0.0304	0.6588	-.1492	0.1746	0.7941	0.4930
MDFSMBD	0.0576	-.1020	0.2192	0.0448	-.0211	0.5616	0.1478
MBW	0.6758	0.6204	0.2350	-.1313	0.2904	-.1877	-.0399
CPD	1.0000	0.6515	0.6291	0.0272	0.5667	0.5346	0.3242
CPW	0.6515	1.0000	0.0117	-.2018	0.3068	0.1429	-.4050
HD	0.6291	0.0117	1.0000	-.3070	0.4652	0.7210	0.7785
TRUNK	0.0272	-.2018	-.3070	1.0000	0.1083	-.0183	0.0841
PFW	0.5667	0.3068	0.4652	0.1083	1.0000	0.4956	0.2273
PFL	0.5346	0.1429	0.7210	-.0183	0.4956	1.0000	0.5861
PECAREA	0.3242	-.4050	0.7785	0.0841	0.2273	0.5861	1.0000
PECASP	0.0385	0.6298	-.2897	-.2046	0.2183	0.1972	-.6388
EYELOC	0.1880	-.2639	0.4116	0.0428	-.0852	0.1419	0.7445
PECPEL	-.4175	-.2124	-.5298	0.4627	-.4809	-.3753	-.1992
EYESIZ	-.1701	0.0381	0.2044	-.5578	0.0908	0.3936	-.1393
CPL	-.4173	0.0166	-.5984	-.0761	-.2610	-.7575	-.5423
CFL	0.4300	0.3088	0.5304	-.2011	0.2991	0.8372	0.3889
EYESIZHD	-.6135	0.0234	-.5863	-.2368	-.2725	-.2174	-.6946
CFDMBD	-.3043	-.4345	-.2819	0.6719	-.2034	0.2049	0.2412
MBDMBW	0.3981	-.1597	0.8815	-.3173	0.2574	0.7684	0.8091
CFAREA	0.2422	-.3905	0.6613	0.0521	-.0263	0.5329	0.9454
CFASP	-.1891	0.4682	-.3587	-.4293	-.0574	-.1986	-.7683
CFASP2	0.1724	-.4940	0.3634	0.4443	0.0235	0.2498	0.7838
CFASP22	0.2941	0.4864	-.1898	0.2948	0.6309	0.2051	-.4261
ADFAF	0.4620	-.0389	0.8836	-.4033	0.1408	0.6286	0.7364
PDFAF	0.5768	-.0577	0.9550	-.2569	0.3497	0.6828	0.8257
JMAX	-.1244	-.6618	0.4534	0.0936	0.1325	0.4846	0.6859
ENERDF	0.3440	0.4310	-.3259	0.5780	0.1372	-.1699	-.1522
AFVMCF	-.0949	0.0525	0.0522	-.3150	0.3540	0.0056	-.1168
PECPEL	-.4175	-.2124	-.5298	0.4627	-.4809	-.3753	-.1992
ENERPEC	0.7512	0.1197	0.9603	-.1777	0.5076	0.7372	0.7649
ADFPEL	0.6924	0.1672	0.9215	-.3292	0.3415	0.6571	0.7451
VMCFDMCF	0.5952	-.0816	0.7626	-.0675	0.2996	0.3760	0.7267
ENERPEL	0.3564	-.1200	0.6583	-.1489	-.0065	0.3903	0.7745
MAXPEC	0.8703	0.6907	0.5331	-.2198	0.4917	0.4754	0.2573
PELAF	0.4422	0.3887	0.2601	-.3098	-.1996	0.0507	0.0376
CPINDEX	0.6520	-.1370	0.8305	0.1709	0.4459	0.5511	0.8539

Table G.5 *continued*. Correlation coefficient matrix for pelagic minnows.

	PECASP	EYELOC	PECPEL	EYESIZ	CPL	CFL	EYESIZHD
ACF1	0.3629	-.1550	-.1248	-.1102	-.0158	0.2691	0.0843
CFD	-.3624	0.5972	-.1977	-.1097	-.6900	0.6226	-.5643
MBD	-.2984	0.4672	-.4793	0.0952	-.5895	0.5451	-.5992
TLDF	-.3109	0.3627	0.3870	-.2566	-.4325	0.3834	-.5008
MDFS	0.0169	0.1548	-.4868	0.2792	-.4731	0.5090	-.2816
MDFSMBD	0.1863	-.1356	-.2931	0.3016	-.2212	0.2713	0.0576
MBW	-.1086	0.1913	-.1473	-.3836	0.0848	-.1322	-.4934
CPD	0.0385	0.1880	-.4175	-.1701	-.4173	0.4300	-.6135
CPW	0.6298	-.2639	-.2124	0.0381	0.0166	0.3088	0.0234
HD	-.2897	0.4116	-.5298	0.2044	-.5984	0.5304	-.5863
TRUNK	-.2046	0.0428	0.4627	-.5578	-.0761	-.2011	-.2368
PFW	0.2183	-.0852	-.4809	0.0908	-.2610	0.2991	-.2725
PFL	0.1972	0.1419	-.3753	0.3936	-.7575	0.8372	-.2174
PECAREA	-.6388	0.7445	-.1992	-.1393	-.5423	0.3889	-.6946
PECASP	1.0000	-.6533	-.1191	0.5865	-.0178	0.3666	0.6981
EYELOC	-.6533	1.0000	-.0162	-.4456	-.1888	0.0315	-.6760
PECPEL	-.1191	-.0162	1.0000	-.3350	0.1149	-.3023	0.1150
EYESIZ	0.5865	-.4456	-.3350	1.0000	-.3594	0.5195	0.6695
CPL	-.0178	-.1888	0.1149	-.3594	1.0000	-.6733	0.1330
CFL	0.3666	0.0315	-.3023	0.5195	-.6733	1.0000	0.0473
EYESIZHD	0.6981	-.6760	0.1150	0.6695	0.1330	0.0473	1.0000
CFDMBD	-.1229	0.1840	0.3391	-.2475	-.1287	0.1179	0.0132
MBDMBW	-.2705	0.3955	-.4446	0.3154	-.7215	0.6800	-.3807
CFAREA	-.6308	0.7415	-.0843	-.1619	-.5182	0.4494	-.6167
CFASP	0.7911	-.7369	-.0171	0.6136	0.2707	0.0933	0.7593
CFASP2	-.7686	0.7295	0.0063	-.5646	-.3147	-.0415	-.7244
CFASP22	0.6445	-.5410	-.1987	0.0820	-.0682	0.0599	0.2155
ADFAF	-.3097	0.4401	-.2503	0.2445	-.6932	0.5869	-.4493
PDFAF	-.3801	0.4661	-.3766	0.1434	-.7036	0.5589	-.5863
JMAX	-.3919	0.3990	-.3126	0.1709	-.4194	0.1655	-.1978
PNERDF	0.0379	0.1569	0.1304	-.6549	0.3305	-.1779	-.3087
AFVMCF	0.2179	-.3488	-.5087	0.3328	0.3967	0.1153	0.2326
PECPEL	-.1191	-.0162	1.0000	-.3350	0.1149	-.3023	0.1150
PNERPEC	-.2934	0.3926	-.5531	0.0408	-.5417	0.5388	-.6876
ADFPCL	-.2848	0.4803	-.4350	0.1060	-.6039	0.5989	-.5924
VMCFDMCF	-.5887	0.6218	-.4176	-.2629	-.4866	0.0975	-.7751
PNERPEL	-.5209	0.6201	0.0220	-.0754	-.5494	0.4717	-.5321
MAXPEC	0.1567	0.2512	-.6017	-.0422	-.3733	0.5181	-.4119
PELAF	-.0505	0.0428	-.0435	0.0202	-.3937	0.3101	-.1451
CPINDEX	-.5834	0.5840	-.3452	-.2511	-.5813	0.2556	-.8276

Table G.5 *continued.* Correlation coefficient matrix for pelagic minnows.

	CFDMBD	MBDMBW	CFAREA	CFASP	CFASP2	CFASP22	ADFAF
ACF1	-.1431	-.1346	-.2236	0.1740	-.2192	0.4317	-.1695
CFD	0.4490	0.8070	0.8985	-.7182	0.7532	-.1526	0.6656
MBD	-.3807	0.8517	0.6535	-.3623	0.3457	-.2370	0.9014
TLDF	0.2463	0.4025	0.6034	-.3644	0.3704	-.2131	0.5482
MDFS	0.1527	0.6703	0.4765	-.2632	0.3223	0.0248	0.5227
MDFSMBD	0.3914	0.2891	0.1612	-.0840	0.1622	0.1664	0.0754
MBW	-.6863	-.0874	-.1235	0.0122	-.0880	0.0496	0.1588
CPD	-.3043	0.3981	0.2422	-.1891	0.1724	0.2941	0.4620
CPW	-.4345	-.1597	-.3905	0.4682	-.4940	0.4864	-.0389
HD	-.2819	0.8815	0.6613	-.3587	0.3634	-.1898	0.8836
TRUNK	0.6719	-.3173	0.0521	-.4293	0.4443	0.2948	-.4033
PFW	-.2034	0.2574	-.0263	-.0574	0.0235	0.6309	0.1408
PFL	0.2049	0.7684	0.5329	-.1986	0.2498	0.2051	0.6286
PECAREA	0.2412	0.8091	0.9454	-.7683	0.7838	-.4261	0.7364
PECASP	-.1229	-.2705	-.6308	0.7911	-.7686	0.6445	-.3097
EYELOC	0.1840	0.3955	0.7415	-.7369	0.7295	-.5410	0.4401
PECPEL	0.3391	-.4446	-.0843	-.0171	0.0063	-.1987	-.2503
EYESIZ	-.2475	0.3154	-.1619	0.6136	-.5646	0.0820	0.2445
CPL	-.1287	-.7215	-.5182	0.2707	-.3147	-.0682	-.6932
CFL	0.1179	0.6800	0.4494	0.0933	-.0415	0.0599	0.5869
EYESIZHD	0.0132	-.3807	-.6167	0.7593	-.7244	0.2155	-.4493
CFDMBD	1.0000	-.0152	0.3503	-.4480	0.5122	0.0312	-.2428
MBDMBW	-.0152	1.0000	0.7968	-.4208	0.4475	-.2760	0.9126
CFAREA	0.3503	0.7968	1.0000	-.7429	0.7716	-.5563	0.7372
CFASP	-.4480	-.4208	-.7429	1.0000	-.9934	0.2571	-.3219
CFASP2	0.5122	0.4475	0.7716	-.9934	1.0000	-.2660	0.3299
CFASP22	0.0312	-.2760	-.5563	0.2571	-.2660	1.0000	-.4038
ADFAF	-.2428	0.9126	0.7372	-.3219	0.3299	-.4038	1.0000
PDFAF	-.2028	0.9324	0.7636	-.4525	0.4551	-.2760	0.9574
JMAX	0.4169	0.5976	0.5950	-.6046	0.6482	-.1862	0.3347
ENERDF	0.2423	-.4898	-.1582	-.1602	0.1400	0.2806	-.5052
AFVMCF	-.2369	0.0066	-.2032	0.3434	-.3583	0.0722	-.1910
PECPEL	0.3391	-.4446	-.0843	-.0171	0.0063	-.1987	-.2503
ENERPEC	-.1897	0.8415	0.6694	-.4371	0.4398	-.0924	0.8057
ADFPEL	-.2953	0.8709	0.7030	-.3772	0.3703	-.2779	0.9055
VMCFMCF	-.1886	0.6724	0.6245	-.7207	0.6984	-.1657	0.6783
ENERPEL	-.0644	0.7455	0.8283	-.4985	0.4885	-.5959	0.8373
MAXPEC	-.3128	0.4382	0.2276	-.1288	0.1120	0.2653	0.4288
PELAF	-.3854	0.3152	0.1853	0.0608	-.0663	-.1908	0.5233
CPINDEX	-.0095	0.7114	0.7247	-.7401	0.7352	-.1248	0.6818

Table G.5 *continued*. Correlation coefficient matrix for pelagic minnows.

	PDFAF	JMAX	PNERDF	AFVMCF	PECPEL	PNERPEC	ADFPEL
ACF1	-.1005	-.4558	0.4350	0.2184	-.1248	-.0571	0.0558
CFD	0.7476	0.6005	-.0180	-.2129	-.1977	0.7229	0.7015
MBD	0.9480	0.2703	-.2237	0.0025	-.4793	0.9112	0.9842
TLDF	0.5255	-.0566	-.0768	-.4812	0.3870	0.3977	0.3910
MDFS	0.5547	0.5798	-.1750	0.0205	-.4868	0.7011	0.5656
MDFSMBD	0.0915	0.5362	-.1054	0.0609	-.2931	0.2714	0.0759
MBW	0.2115	-.5313	0.4025	-.0710	-.1473	0.2899	0.3751
CPD	0.5768	-.1244	0.3440	-.0949	-.4175	0.7512	0.6924
CPW	-.0577	-.6618	0.4310	0.0525	-.2124	0.1197	0.1672
HD	0.9550	0.4534	-.3259	0.0522	-.5298	0.9603	0.9215
TRUNK	-.2569	0.0936	0.5780	-.3150	0.4627	-.1777	-.3292
PFW	0.3497	0.1325	0.1372	0.3540	-.4809	0.5076	0.3415
PFL	0.6828	0.4846	-.1699	0.0056	-.3753	0.7372	0.6571
PECAREA	0.8257	0.6859	-.1522	-.1168	-.1992	0.7649	0.7451
PECASP	-.3801	-.3919	0.0379	0.2179	-.1191	-.2934	-.2848
EYELOC	0.4661	0.3990	0.1569	-.3488	-.0162	0.3926	0.4803
PECPEL	-.3766	-.3126	0.1304	-.5087	1.0000	-.5531	-.4350
EYESIZ	0.1434	0.1709	-.6549	0.3328	-.3350	0.0408	0.1060
CPL	-.7036	-.4194	0.3305	0.3967	0.1149	-.5417	-.6039
CFL	0.5589	0.1655	-.1779	0.1153	-.3023	0.5388	0.5989
EYESIZHD	-.5863	-.1978	-.3087	0.2326	0.1150	-.6876	-.5924
CFDMBD	-.2028	0.4169	0.2423	-.2369	0.3391	-.1897	-.2953
MBDMBW	0.9324	0.5976	-.4898	0.0066	-.4446	0.8415	0.8709
CFAREA	0.7636	0.5950	-.1582	-.2032	-.0843	0.6694	0.7030
CFASP	-.4525	-.6046	-.1602	0.3434	-.0171	-.4371	-.3772
CFASP2	0.4551	0.6482	0.1400	-.3583	0.0063	0.4398	0.3703
CFASP22	-.2760	-.1862	0.2806	0.0722	-.1987	-.0924	-.2779
ADFAF	0.9574	0.3347	-.5052	-.1910	-.2503	0.8057	0.9055
PDFAF	1.0000	0.4321	-.3861	-.1057	-.3766	0.9132	0.9395
JMAX	0.4321	1.0000	-.3073	0.0783	-.3126	0.4042	0.3193
PNERDF	-.3861	-.3073	1.0000	-.0021	0.1304	-.1251	-.1820
AFVMCF	-.1057	0.0783	-.0021	1.0000	-.5087	0.0803	0.0120
PECPEL	-.3766	-.3126	0.1304	-.5087	1.0000	-.5531	-.4350
PNERPEC	0.9132	0.4042	-.1251	0.0803	-.5531	1.0000	0.9213
ADFPEL	0.9395	0.3193	-.1820	0.0120	-.4350	0.9213	1.0000
VMCFDMCF	0.7921	0.4696	-.0860	-.2607	-.4176	0.7806	0.7676
PNERPEL	0.8071	0.2644	-.1902	-.1797	0.0220	0.6310	0.8271
MAXPEC	0.5111	-.0944	0.2788	0.0198	-.6017	0.6416	0.6754
PELAF	0.4219	-.4130	-.2027	-.4102	-.0435	0.2671	0.4409
CPINDEX	0.8414	0.5238	0.0028	-.1853	-.3452	0.8664	0.7851

Table G.5 *continued*. Correlation coefficient matrix for pelagic minnows.

	VMCFDMCF	PNERPEL	MAXPEC	PELAF	CPINDEX
ACF1	-.0938	0.0563	0.5615	0.2817	-.0986
CFD	0.6307	0.6980	0.4438	0.1595	0.7625
MBD	0.8008	0.8009	0.7014	0.4923	0.7950
TLDF	0.2351	0.5832	0.0913	0.3585	0.4315
MDFS	0.4550	0.2148	0.3472	-.0256	0.5036
MDFSMBD	0.0529	-.2133	-.0312	-.3167	0.1188
MBW	0.3979	0.2416	0.6092	0.4703	0.3026
CPD	0.5952	0.3564	0.8703	0.4422	0.6520
CPW	-.0816	-.1200	0.6907	0.3887	-.1370
HD	0.7626	0.6583	0.5331	0.2601	0.8305
TRUNK	-.0675	-.1489	-.2198	-.3098	0.1709
PFW	0.2996	-.0065	0.4917	-.1996	0.4459
PFL	0.3760	0.3903	0.4754	0.0507	0.5511
PECAREA	0.7267	0.7745	0.2573	0.0376	0.8539
PECASP	-.5887	-.5209	0.1567	-.0505	-.5834
EYELOC	0.6218	0.6201	0.2512	0.0428	0.5840
PECPEL	-.4176	0.0220	-.6017	-.0435	-.3452
EYESIZ	-.2629	-.0754	-.0422	0.0202	-.2511
CPL	-.4866	-.5494	-.3733	-.3937	-.5813
CFL	0.0975	0.4717	0.5181	0.3101	0.2556
EYESIZHD	-.7751	-.5321	-.4119	-.1451	-.8276
CFDMBD	-.1886	-.0644	-.3128	-.3854	-.0095
MBDMBW	0.6724	0.7455	0.4382	0.3152	0.7114
CFAREA	0.6245	0.8283	0.2276	0.1853	0.7247
CFASP	-.7207	-.4985	-.1288	0.0608	-.7401
CFASP2	0.6984	0.4885	0.1120	-.0663	0.7352
CFASP22	-.1657	-.5959	0.2653	-.1908	-.1248
ADFAF	0.6783	0.8373	0.4288	0.5233	0.6818
PDFAF	0.7921	0.8071	0.5111	0.4219	0.8414
JMAX	0.4696	0.2644	-.0944	-.4130	0.5238
ENERDF	-.0860	-.1902	0.2788	-.2027	0.0028
AFVMCF	-.2607	-.1797	0.0198	-.4102	-.1853
PECPEL	-.4176	0.0220	-.6017	-.0435	-.3452
ENERPEC	0.7806	0.6310	0.6416	0.2671	0.8664
ADFPEL	0.7676	0.8271	0.6754	0.4409	0.7851
VMCFDMCF	1.0000	0.6038	0.5561	0.3186	0.9106
PNERPEL	0.6038	1.0000	0.3564	0.4793	0.6419
MAXPEC	0.5561	0.3564	1.0000	0.4943	0.4921
PELAF	0.3186	0.4793	0.4943	1.0000	0.1942
CPINDEX	0.9106	0.6419	0.4921	0.1942	1.0000

Vitae

Matthew Chan was born in November just after humans first stepped on the moon. He grew up in East Liverpool, Ohio. From an early age he spent much time playing in muck and small streams and most of his summers were spent at Leesville Lake in the Muskingum Watershed District, Carrollton, Ohio. He attended undergraduate college at Wittenberg University, Springfield, OH, where, in 1992, he obtained his B.A. with a biology major and computer science minor. While attending school he worked with the staff of the Computer Center as an assistant to the system administrator and then the computer technicians. Immediately after graduation he took a job with a small landscape company where he was placed in charge of the office and bookkeeping. At the end of the summer, he left Ohio for Mississippi to pursue his Master's degree.

In 1995, Matthew graduated from the University of Mississippi, Oxford, Mississippi, with a M.S. in Biology. His thesis title was "Life history and bioenergetics of the brown madtom, *Noturus phaeus*." and his advisor was Dr. Glenn R. Parsons. From Olemiss he went to work with the US Corps of Engineers at Waterways Experiment Station in Vicksburg, MS. Because he was on contract and not full time, when the Republican dominated U.S. Congress shut down the government he decided it was a great time to continue his graduate education. He began graduate school for the second and hopefully last time in the autumn of 1996 in the Department of Fisheries and Wildlife Sciences at Virginia Polytechnic Institute and State University, Blacksburg, VA. His advisor was Dr. Donald J. Orth. In the last four years he has served as graduate teaching assistant, an intern class co-instructor, an instructor, a project coordinator and graduate research assistant. At Virginia Tech, with more than just a little luck and support from his friends, family, and the faculty, he completed this volume and graduated with his Ph.D. in Fisheries Science in the spring of 2001.