

A Thesis submitted to the faculty of Virginia
Polytechnic Institute and State University in partial fulfillment
of the requirements for the degree : Master of Architecture, May 1999
Blacksburg, Virginia

Inspiration to Illumination

by Kartikey Patel

Michael O' Brien, Chair

William Green

Dennis Kilper

Heinrich Schnoedt

Index

Pg.no

1. Abstract	1
2. Inspiration from the work of Carlo Scarpa	2
3. Lamp as a whole - Alternative 1	12
4. Lamp as a whole - Alternative 2	14
5. Process	16
6. Conclusion	33
7. Bibliography	34
8. Photo Credits	35
9. Vita	36



Abstract

This thesis is the result of insights gained from investigation of the work of Carlo Scarpa and applied to the making of a lamp. Scarpa's work has influenced this work in many ways but most fascinating is the way detail is used. The indirect connection between parts and blending of precious and semiprecious metals conveys its own language. Geometry, one of the governing aspects of his design is a primary characteristic in the composition of spaces. The way different metals are used and the ways different spaces are created are fundamental throughout his work. This project is an attempt to make a lamp which is more than an object. Different metals like steel, brass, copper and aluminum are treated in extreme conditions and the range of different materials are part of a process. In the process of making, the design has taken a few turns. An ongoing dialogue with objects and an empirical process of evaluating and analyzing past objects were used to support the next decision. Often details are designed on the spot in the shop. The Lamp has had two reflectors. The design of the reflector is part of an on going process. Although this object may not be as functionally efficient as other lamps, it has provided an opportunity for discourse and acts as a vehicle for further investigation. Many enjoyable moments are the part of its qualified success and it has opened up a wide horizon of architectural gesturing.



Scarpa never used analytical architecture based on juxtaposition of geometrically defined volumes. He accepted a Neoclassicism. Through this figure he gradually achieved a transition to the pure forms of modern architecture.¹

One example of pure form can be seen in a column at Quarini Stampalia where different materials like concrete, glass and brass come together and provide an example of modern architecture. Scarpa works with lines to keep them continuous. He takes his line to a point of extreme tension and then gives relief to it. Such relief point also acts as a transition when the horizontal becomes vertical or vice versa.



Detail of stari at Banca Popolare



Column at Quarini Stampalia

In Scarpa's architecture it is difficult to find the juxtaposition of clearly defined volumes typical of the paratactic design procedure of the Neoclassicists. In connection with rules of proportion and scale which accompanied and controlled the >filing down< mention should be made of Scarpa's intercast in the geometrical conundrums of Mathila Ghyka.²



a

The corner condition of a building or a joint is always critical in Scarpa's work. His attempt is to avoid the sharp edge at the corner. In order to do that, he staggered the corner at Brion cemetery. He tried to keep his lines continuous where they are edges of his buildings. Whenever he had to end his line, he seldom forms a sharp corner condition. Instead he takes the line further and ends it by merging with another face or object. You can see such condition in the image below where a circle approaches the ground and becomes a horizontal relief, ending the continuous line with a wall.

Scarpa's architecture can be seen as a document of his times. A close reading of that document must focus on his radical and almost exclusive attention to form and on the studied richness of his composition and decoration – characteristic qualities too easily dismissed as aristocratic and elitist. One can agree that Scarpa's emphasis on form originates from a desire to capture the energetic and progressive forces of his time and from a full-hearted commitment to adding an aesthetic dimension to the human condition.³



b



a
Detail of profiling in iron on a passage of the Castelvecchio Museum, Verona.



b
Detail of stair at Banca Popolare, Verona

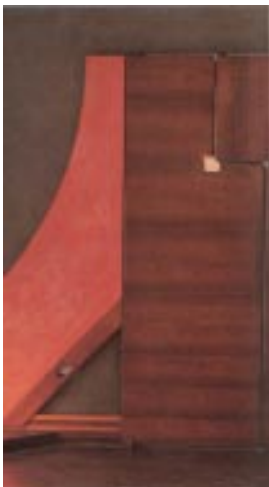

c
Detail of Service door at Olivetti Showroom

In Scarpa's work: Material always expresses its quality in its natural form; as iron, brass, copper, bronze and wood appear in pure condition. They are never treated galvanized, color coated or veneered. Purity of material express its nature.



d
Handrail at Banca Popolare, Verona



Detail of connectors for colonettes and of the trabeation: loggia on the Banca Popolare, Verona

Column detail of Banca Popolare where brass is used at the top of the column for catching attention. A precious material as brass used with iron gives contrast. Here the piece expresses the nature of two columns. The square base of the column becomes octagon and then sixteen sided polygon and eventually becomes circle. The image shows how square column transforms into circle. Such condition is seen at many places in Indian architecture.

Frank Lloyd Wright's work had interested Scarpa for years and he had tried to imagine it from publications, but when at the end of the sixties he was able to see it at first hand he was disappointed by the absence of structural details which, he thought, distinguished the new architecture. Scarpa's own formal language had attained self-sufficiency in these years, and legacy. Architecture was in state of radical change, which alienated it from Wright's. Louis Kahn was developing his architecture of remembrance, which was closely related to Scarpa's design outlook in its attention to details and to joints. Kahn asserted that the joint was at the origin of ornament. When Scarpa applied the Neo-Plasticist decomposition of space, he considered not surfaces but structural joints. Instead of formulating a repartony of rectangular areas without stipulating their location (floor, wall, ceiling) and thus attaining the abstraction of the Dutch De Stijl, Scarpa stressed the joints and sought to enhance them by dissociating the whole into its component parts.⁴

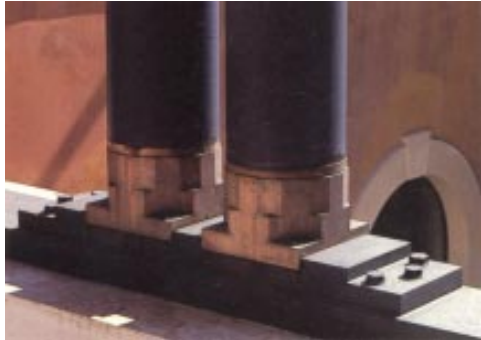

Detail of the base of the Colonettes

The figure below is the end condition of a wall at Brion Cemetary where the edge of the wall is defined by bright yellow mosaic tiles. One of the favorite composition of Scarpa which can be seen repeatedly at different scales and in different projects.

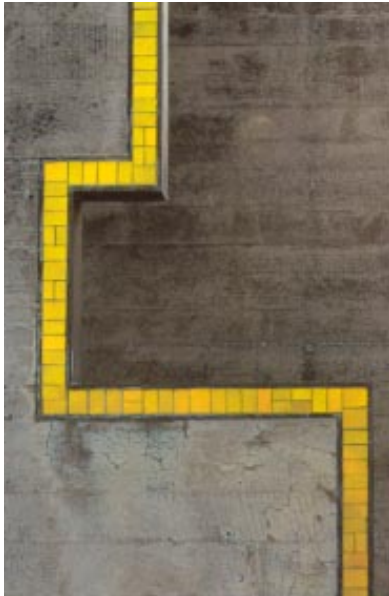

Coloured mosaic fascia defines the wall itself, establish its height and proportion



Water Spout detail at Olivetti Showroom, Geneva

The architecture, by his arrangement of forms, realizes an order which is a pure creation of his spirit; by form and shapes he affects our senses to an acute degree and provokes plastic emotions; by the relationships which he creates he wakes profound echoes in us, he gives us the measure of an order which we feel to be in accordance with that of our world, he determines the various movements of our heart and of our understanding; it is that we experience the sense of beauty.⁵

Indirect connection between elements are present throughout Scarpa's work. In the detail of a barrier the iron piece is attached to wooden barrier with five pieces which make up the indirect connection. The vertical iron piece connected with small inserted brass piece, then brass ring, two iron rings and then brass cap which is inserted in wooden barrier. In the base detail of crucifix, the indirect connection is visible. The iron never touches the ground directly. A piece of steel carries the load of iron and transfers to ground.



Detail of barrier in the Castelvecchio Museum, Verona

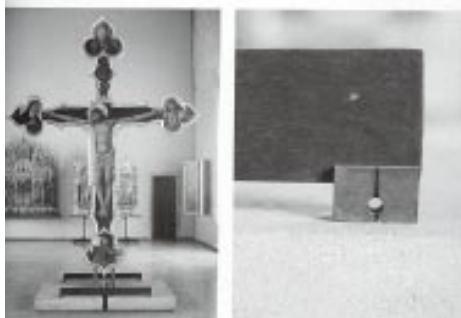

The base of crucifix and detail of it at Castelvecchio Museum, Verona

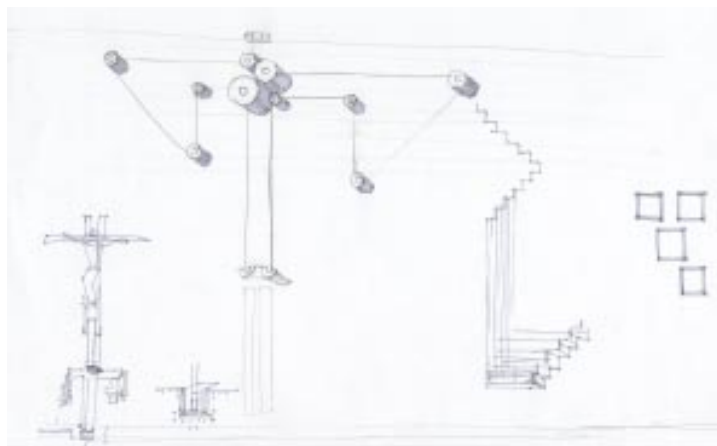



Detail of Door stop

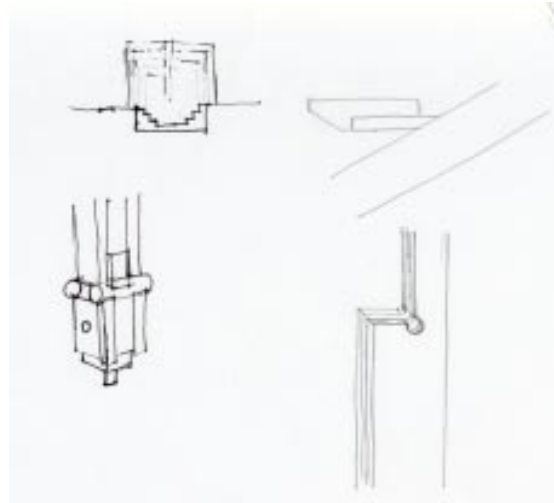

Detail and Craftsmanship: A technical interpretation of Scarpa's design is more appropriate than the usual highly formal approach. Scarpa cultivated communication with the people who were to implement his drawings, developing both their skills and their creativity. His highly personal way of linking the various elements together followed a logic, which was quite different from the normal conceptual logic of language. It seemed rather to derive from a figurative logic which demanded steps at first apparently unnecessary or obvious, but which then proved to be highly productive. This visual thinking which took place as the design was sketched out thus also characterized the modes of reference, the point of departure, for Scarpa's compositional language. Like most abstract architects, Scarpa was of the opinion that shapes have no associative or conventional meanings. Architecture forms, he thought, refers purely to themselves and are based on a non-denotative referentiality on exemplification.⁵

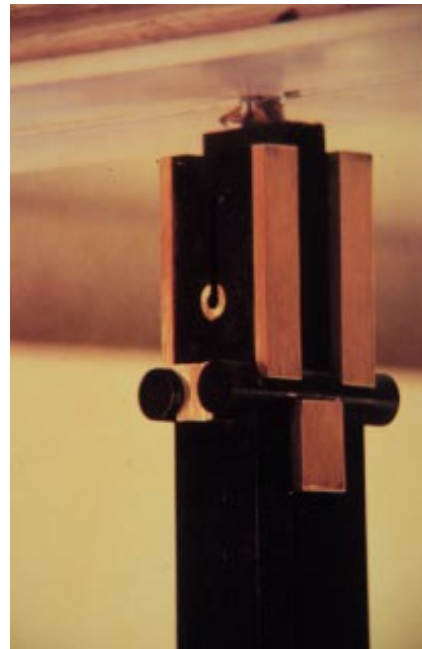

Detail of connection at the top of the column

Material changes are used when they are needed to distinguish between general and precious or strong and beautiful. The material has to find form through its process of making to reflect its characteristics.



a



b

Fixture Detail of a column

Two intersecting circles came to Scarpa's designs from Chinese origin. They are overlapped with different proportions in different conditions of their functional expression.

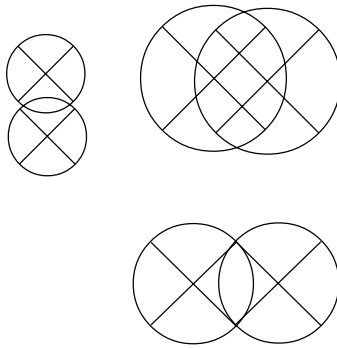

The alteration between exemplification and expression, the hallmark of Scarpa's symbolic system, would confirm its non-denotive referentiality and explain the poetic tension, two elements, which breathe life into his architectural works.⁷



c

Entrance of Brion Family Cemetery, San Vito d' Altivole, Treviso, 1969-78



a

Detail at Brion Family Cemetery, San Vito d'Altivole, Treviso, 1969-78



b

Details of Marble window at Banco Popolare, Verona

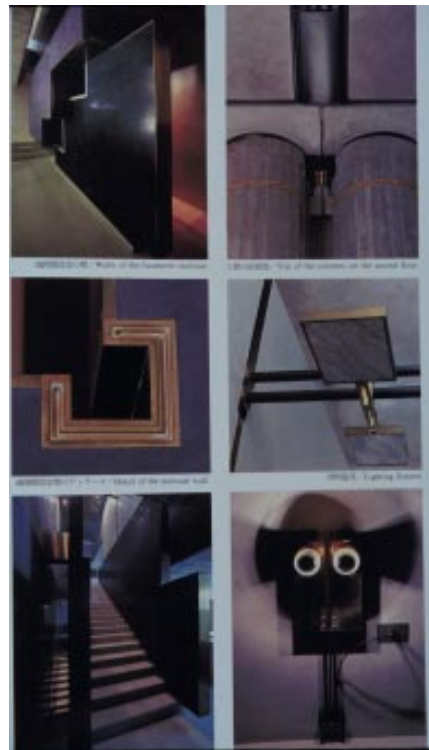

c

Details at Banco Popolare, Verona



a

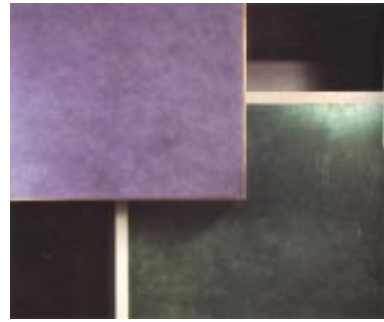

c

Experiment on the work of art : Light, a very characteristic feature of his designs, in Scarpa's work evolved into the language which enabled him to put into discourse. It is an especially diaphanous light, which has become an extraordinary instrument of architectural criticism, much more effective than the verbiage of the art critics.⁸



b

View of Chapel at Brion Cemetery



d

Lamp as a whole - Alternative 1

The idea of design (sketch on opposite page) came in to my mind from the relationship between man and woman; who act as two individual entities that eventually come together. They meet at certain points and disperse. Everything else happens around them, making an entire whole. The cube and top reflector are connected by light.



Computer study model

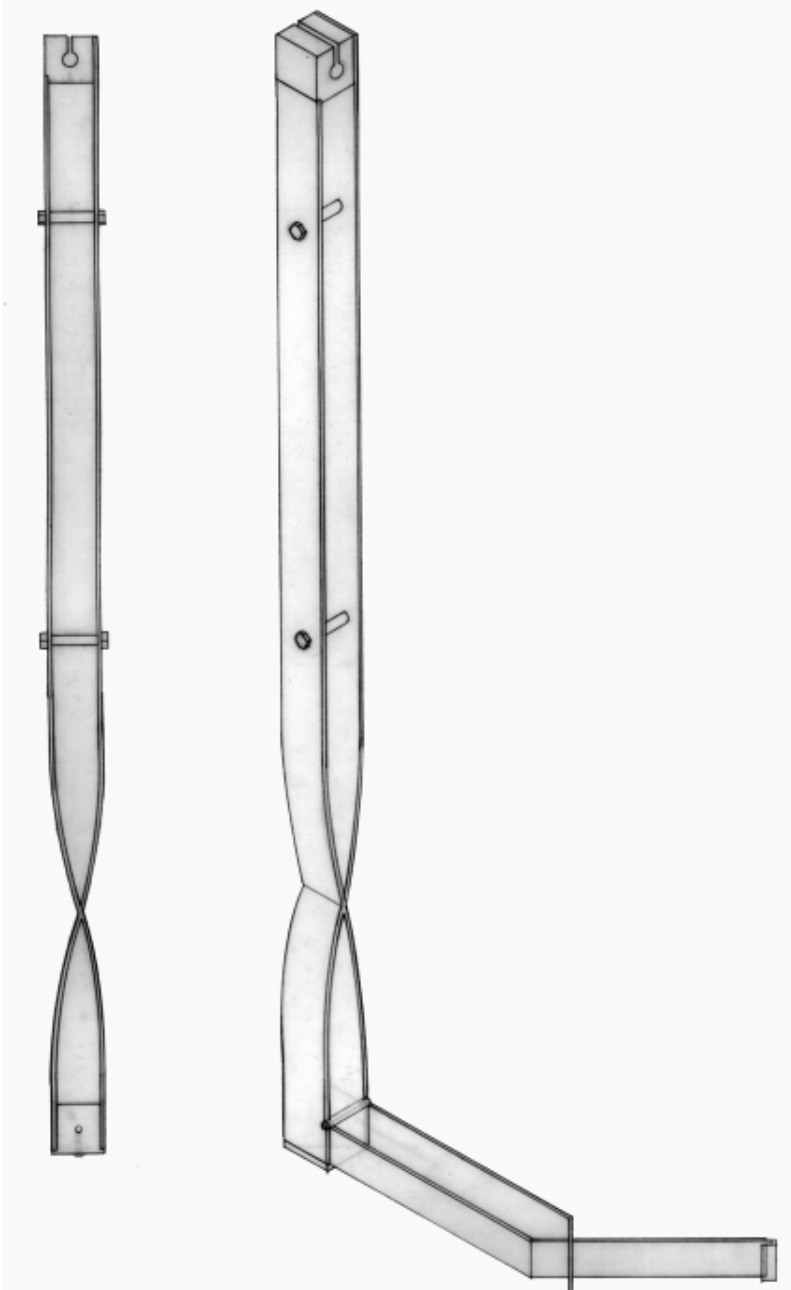

Rear elevation and axonometric of the lamp

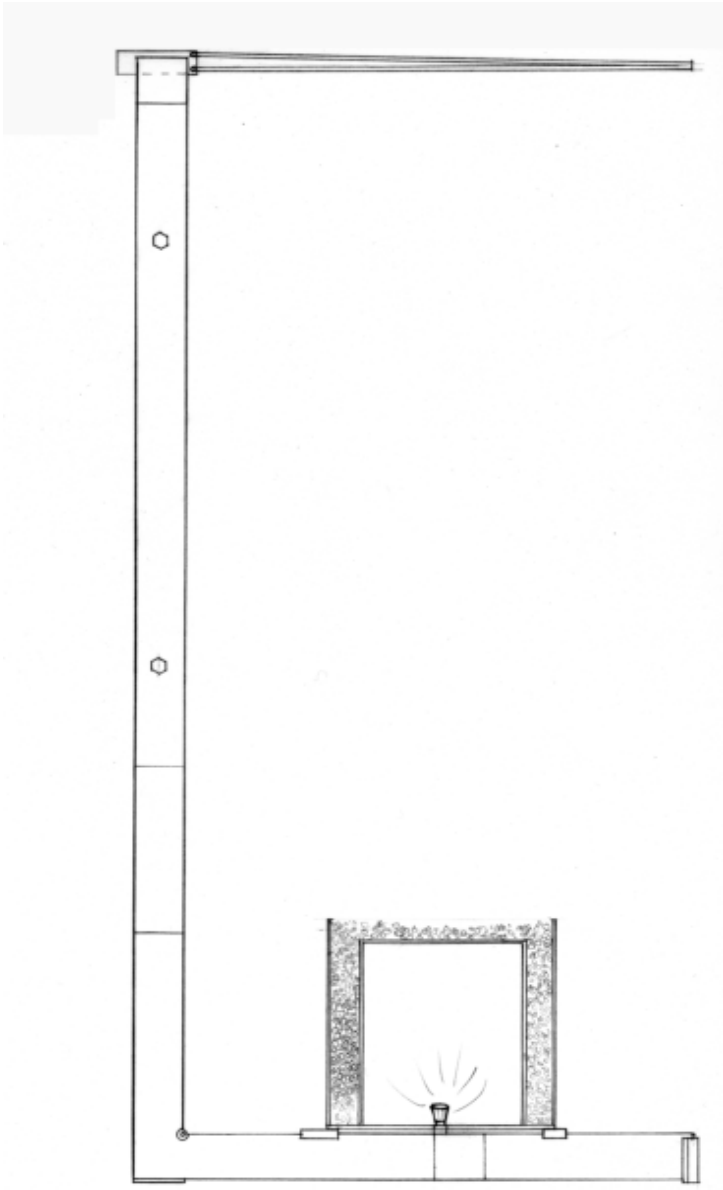

Side elevation of the lamp



Water color of an idea



Lamp as a whole in the dark

Lamp as a whole - Alternative 2

A design change in second lamp is the top reflector. Instead of an elliptical shape it is square acting as an extension of the cube.



Elevation of second alternative



Study model

A Different Perspective



The second version of the reflector is the top projection of the cube which creates two conditions of column. One is a steel column and the other is a column of light. The columns are different in size, weight, material and nature. Their tendency to compete is like human beings although they are of the same nature. This similar phenomenon can be seen in architecture where such condition appears. The column of light expands from its top while the steel column is subtle and calm with its originality and noble nature to support. The steel column supports the top reflector which captures the column of light. The dialogue between the two columns gives me an understanding of architecture.

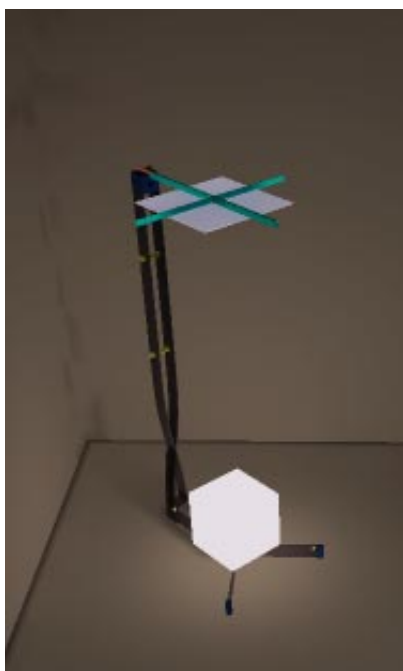

Foreshortened view of a window on Palazzo Steri, Italy



Color pencil render of lamp

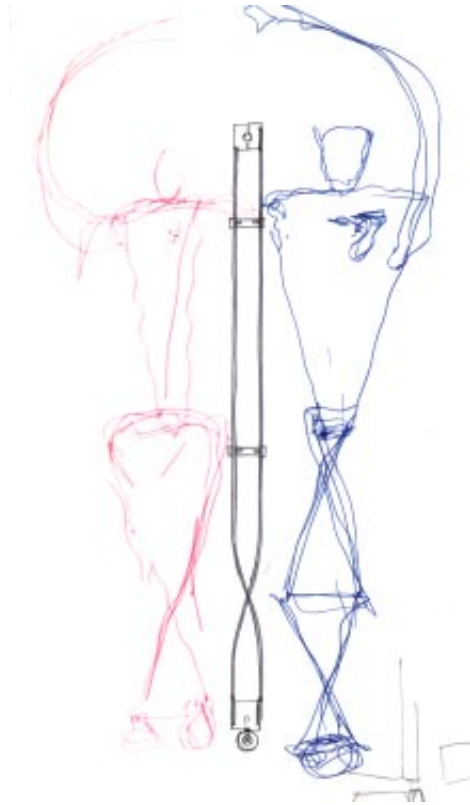



Detail of connection

The cardboard model is 1/3 size of the real model: approximately 2' in height. It was the last model built before going to full scale. The small mock ups were made in real material to measure material resistance and workability. The final model is close to the first study model except for the top reflector. A design decision to make the top reflector adjustable increased the complexity of the top cube. The crossing in vertical steel pieces where two lines becomes a point and then again becomes two lines. Such condition explore tension in overlapping steel members and tests resistance of steel.



Rear view of model



Model with cube

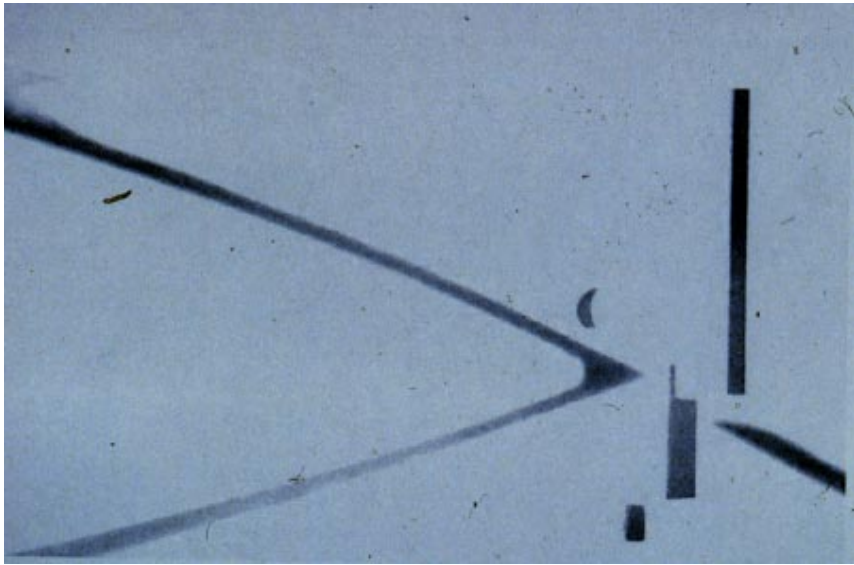

Detail of weldjoint at intersection and leg joint



Detail of Brion cemetary

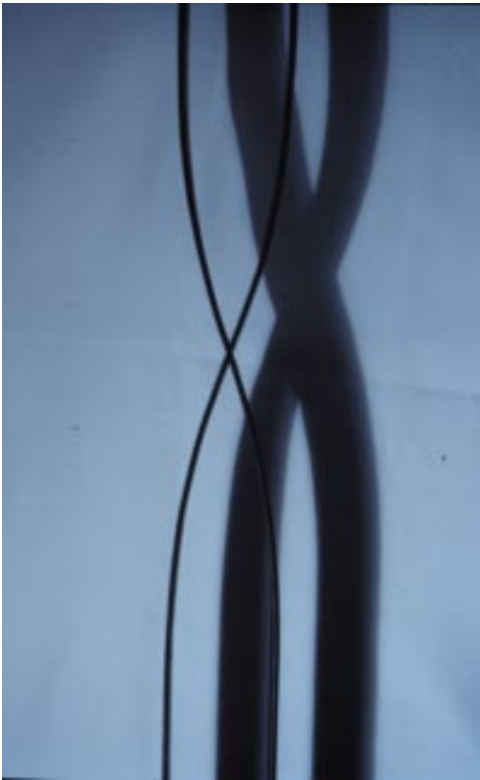

Intersection of vertical members

Mild Steel is bent to make the curve as smooth as possible at the back of the lamp. Both the steel members are half lapped at 45 degrees at the lamp's base and inserted in each other. It is the nature of hot rolled metal to deflect back a little after being bent.

The decision of welding or bolting steel pieces was taken after experimenting with a small piece. Welding does not give very smooth finish and it makes steel pieces act homogeneous. Instead of acting as a separate individual entity, they made it one single piece. By lapping steel pieces and bolting them at the end provides the flexibility of disassembly-reassembly.

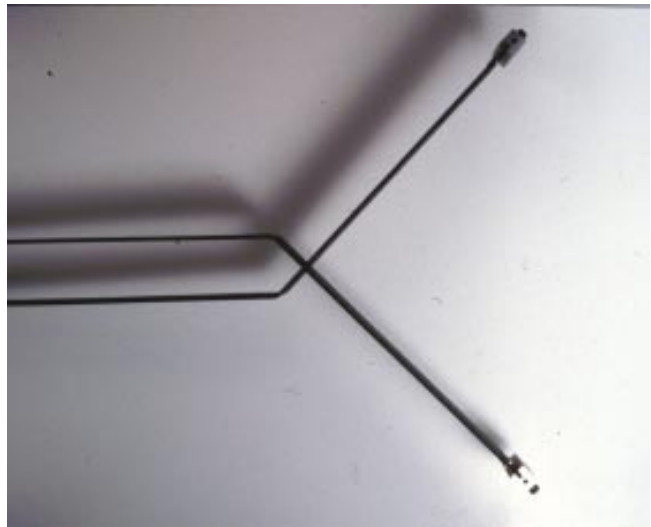

Crossing condition of bottom legs



Sketch showing intersection of bolt in ring

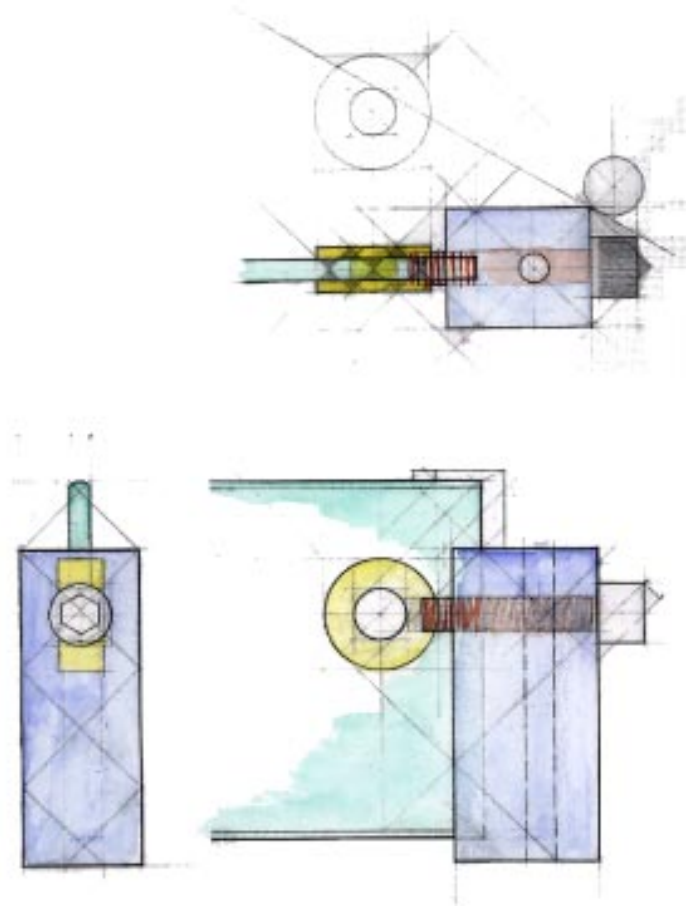



Threaded Steel Flat

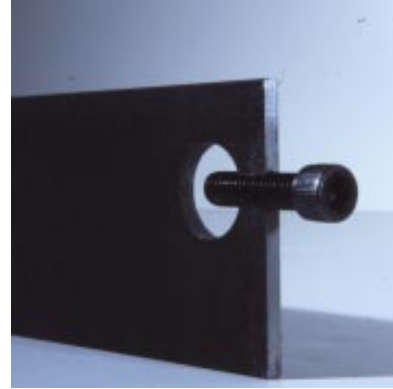

Bolt Inserted in Steel Flat

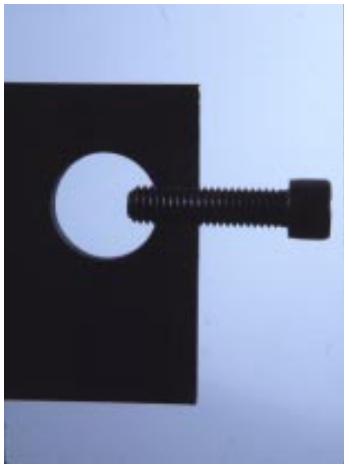

Space in the circle changes as the Bolt is turned in Steel Flat

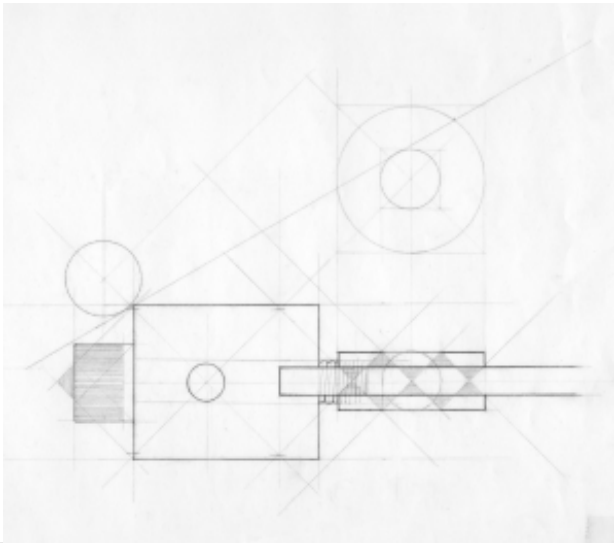

Geometry plays an important role in the joint. Proportions govern the geometry and also material limitations keeps them to certain size. Size of the ring ,bolt and aluminium pieces and their proportions helps to understand the ratio-proportions and how the weight is ultimately transferred to the ground. Brass ring helps the bolt to hold aluminium cube at its position which supports steel flat to carry the load.

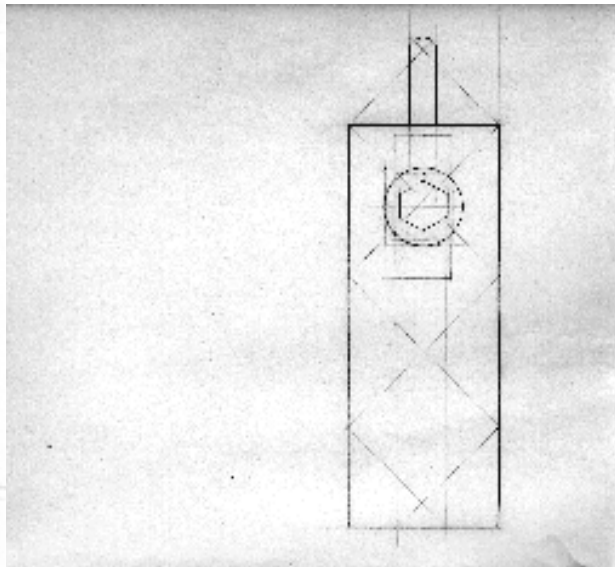
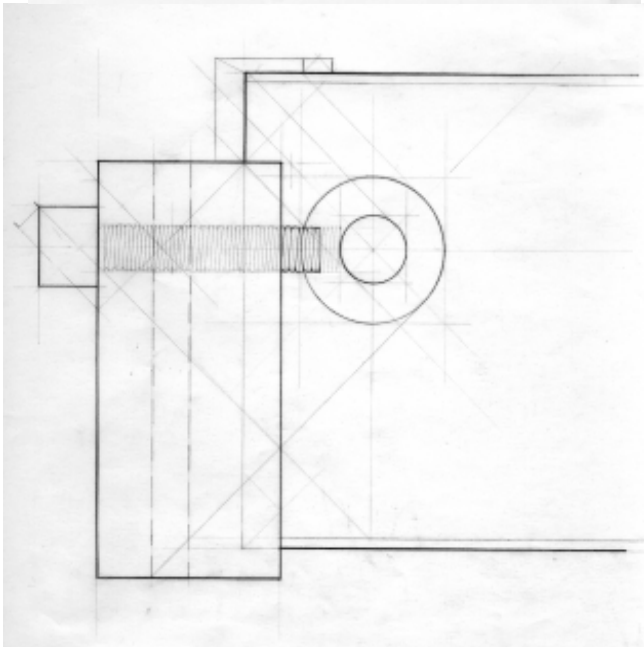

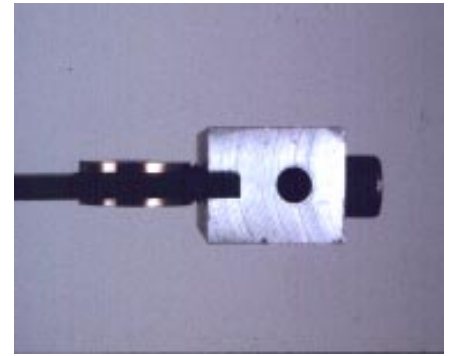

Plan of joint at the end of bottom leg

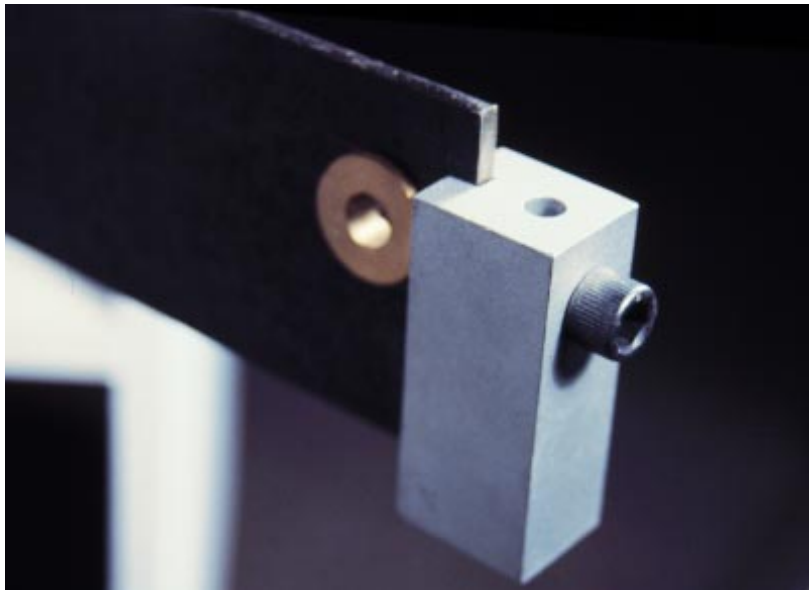

View at the end condition

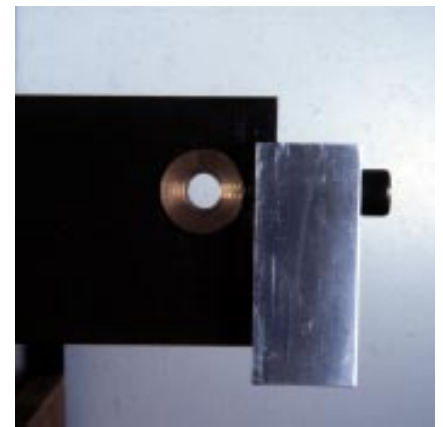

Elevation of joint

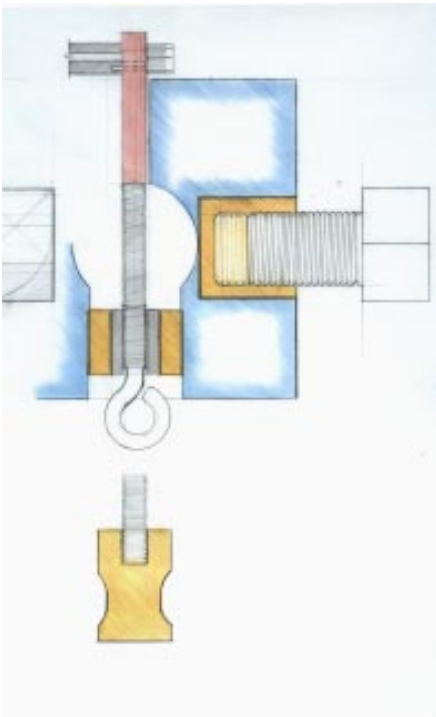

Section from center of Top Cube

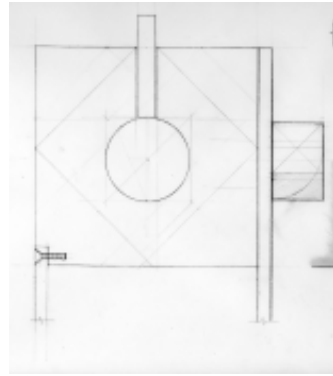
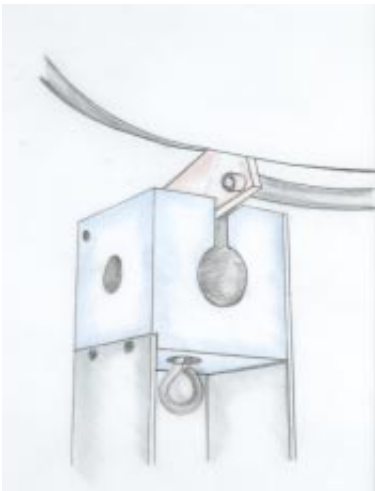

A brass bolt holds the top cube which rests on the top of two steel pieces. It carries weight of top reflector where it is attached by a pin joint. The brass knob has replaced by the eye-bolt for better aesthetics. It is the only place where one touches the lamp to change the angle of the top reflector.

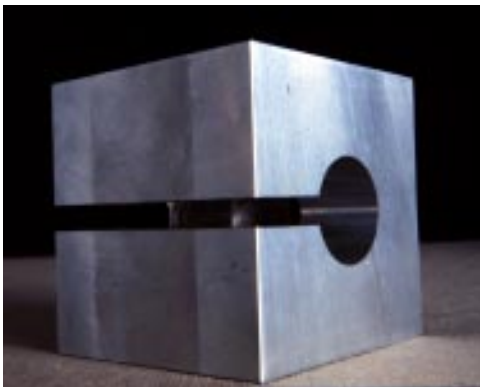
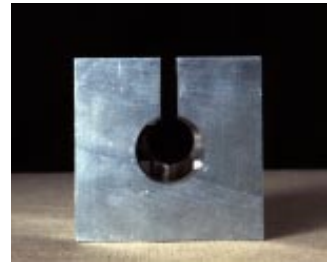

Top cube milled from aluminium

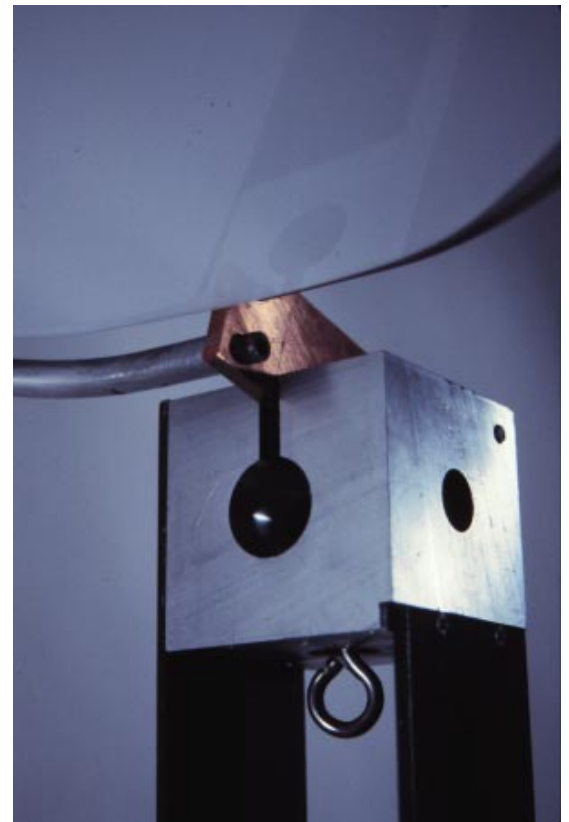

Top cube resting on steel bearing support for reflector

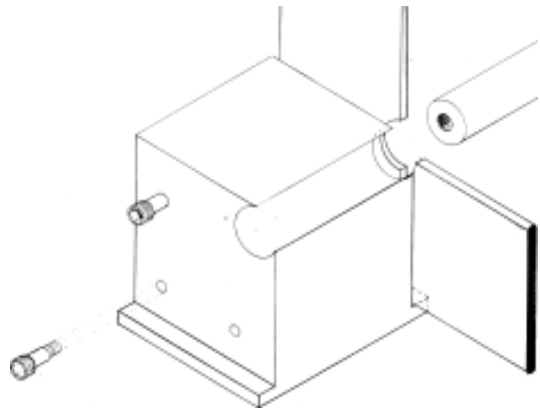

The bottom cube acts as a connector for vertical and horizontal steel pieces. The power cord passes through it. A brass pin and machine bolts hold the whole assembly together.

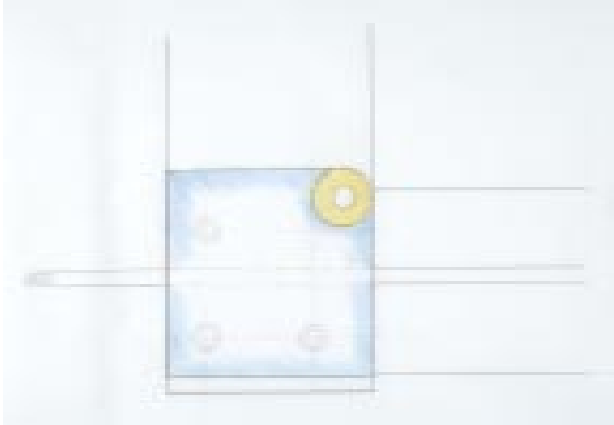

Elevation of the bottom cube

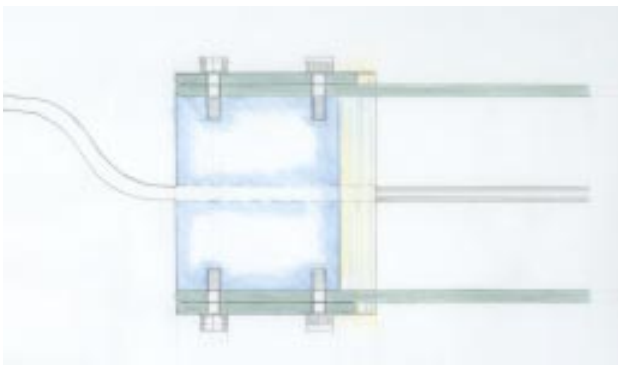

Plan of the bottom cube

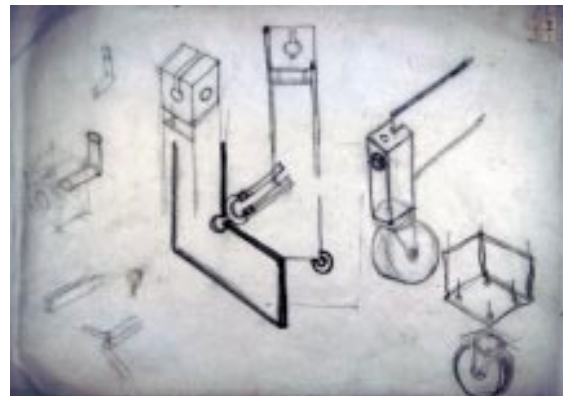

Scarpa adds so much to his line until it reaches the extreme point of tension and then he gives some relief at the joint. It is the extreme point when line needs a relief. This act of relief is expressed here at the corner condition. The pin is added at the connection to give extra strength and stability.

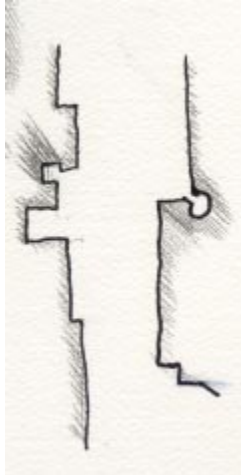

Aluminium cube as a support holds steel pieces and machine bolts keeps them together. Brass pin acts as a connector.

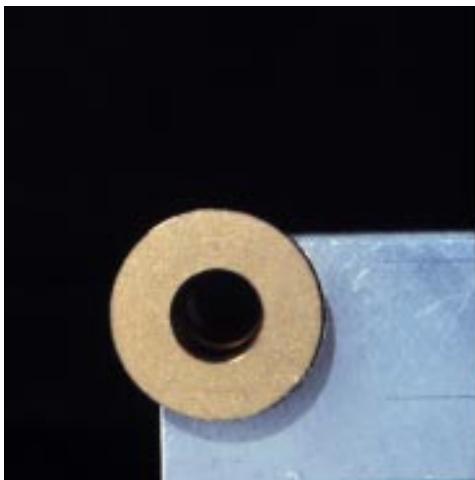

Brass pin holds steel flat and aluminium cube

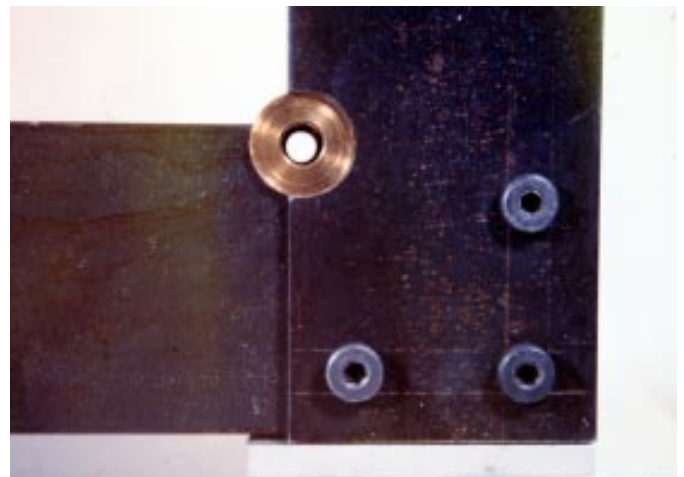

The end condition of the bottom cube



The making of the cube containing broken glass pieces is a similar act as making Terrazzo. Tempered glass pieces are molded in the same way forming a cube. The cube refracts light and generates a bright glow of light.

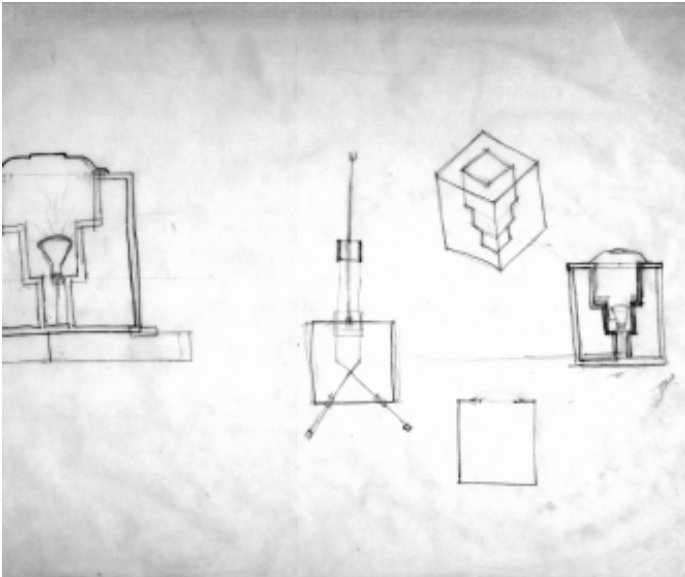

Many ideas and proposals were tried in making the cube. Concentrically embedded staggered cubes were explored to make different intensities of light, but that did not help much. The final decision is to make 1 1/4" sandwich of tempered glass.

The first attempt for making a cube was a 2" solid cube cast with glass pieces and epoxy resin; which has its own difficulties in curing same as the second big hollow 9" solid cube with epoxy resin glass walls. It was cast with two different kind resins which looked efficient but failed against the heat of the bulb.

2" Solid Cube

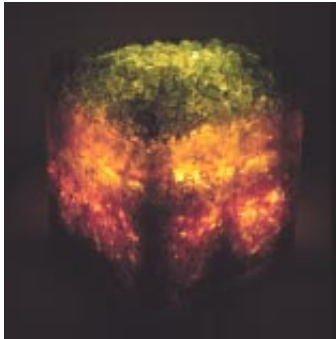

9" Hollow Cube

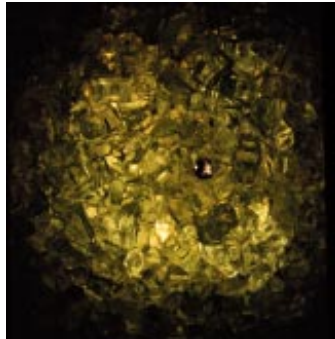

Top View

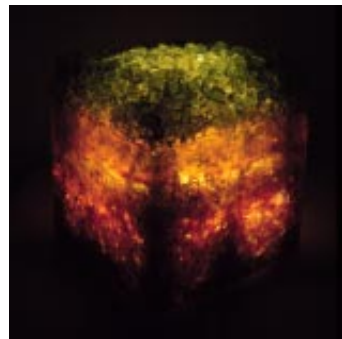

9" Hollow Cube

The enclosure in the final cube is made with plexiglass. Another plexiglass cube is constructed inside it. The void between the cubes is filled with broken tempered glass. The corners of the cube are lapped to the thickness of plexiglass and they are glued and screwed on the edge.



15" Final Cube

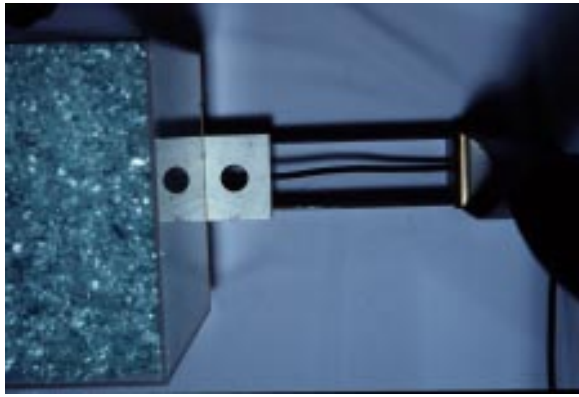

Connection of cord : passing through resting piece and bottom cube

The cube sits on the aluminium pieces and they sit on the steel pieces. There is always an indirect way of joining when two objects meet. The third object acts as a link between two of them.



Indirect connection between cube and steel pieces

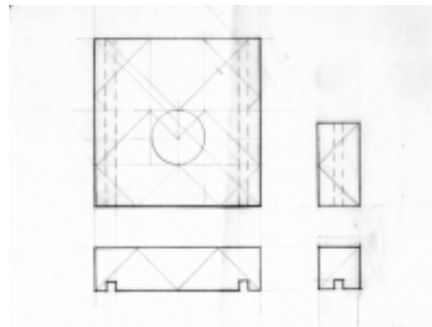

Aluminium pieces rests on steel pieces and transfer the load of the cube.



Section shows how the aluminium rod is fastened to the brass piece with a screw, and the brass piece is holding the plexiglass reflector.



View of the connection

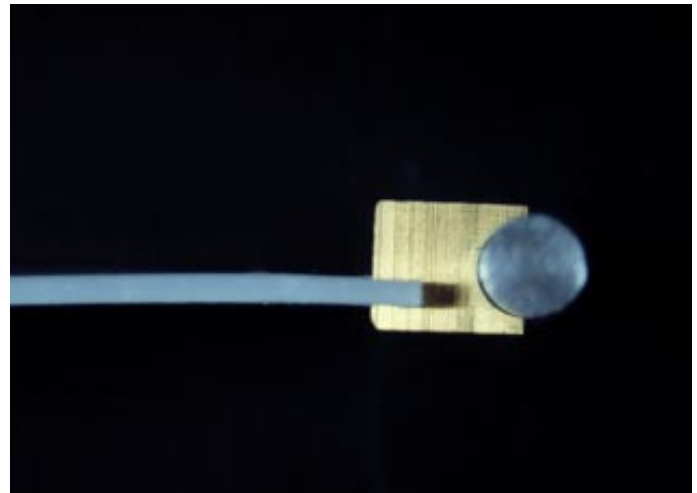

The brass piece acts as a connector which holds the plexiglass and aluminium rod together. Four brass pieces hold the sheet of plexiglass.

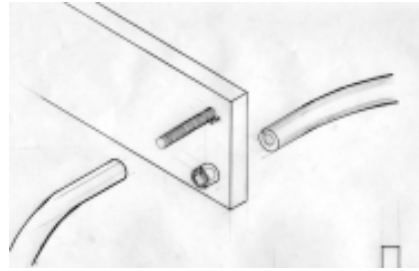
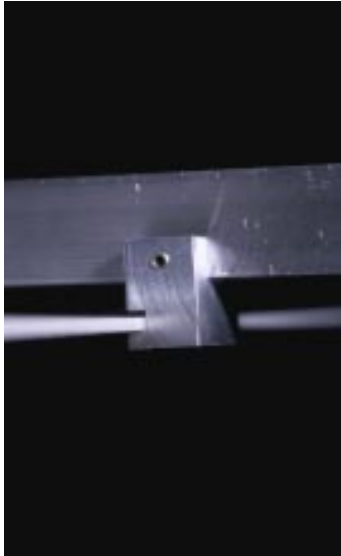

Connection of reflector
Aluminium tube attached by bolts to
the copper plate and pins are added
at the joint to prevent sagging

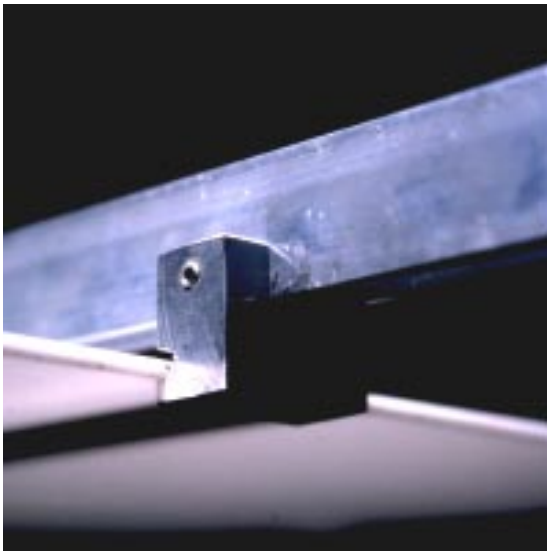

Connector separates aluminum flange and holds
plexiglass



Brass bolts made on the lathe from
hexagonal brass section.

The project started simultaneously with studying Carlo Scarpa's work. It is built at a scale which made it more substantial than initial study models. The starting elements were 20' long 3"x3/16" steel made workable by sizing them into two 6' and two 3'-3" steel elements.

The lamp has interesting moments in the details and acts as an object while lit up. The entire whole is quite complex to understand, but the way all the parts come together gives a better clue to the process of making and of construction.

The steel structure meets strength, weight and volume constraints and has an individual presence in the room. The weight of this object is about 150lbs and the volume is 2'x6'x2'-6". The light bulb was selected after experimenting with different types of bulbs. Finally a 50w halogen bulb with higher(3750) luminosity was selected for its intense focus at the top and an even spread on the sides. Glass pieces are tempered which help to refract light in the cube and give a bright glow in the space. Brass and aluminium are added at the joints with the main structural steel members. Translucent milky plexiglass acts as a top reflector.

The project offered an opportunity to study geometry, detail, processes and materials. The investigation of Scarpa's work and its implication of a full size project gives experience with material, their limitations and the opportunity to solve the joints and connections.

Bibliography

1. Los, S., *Carlo Scarpa. Archietto Poeta*, op.cit Pg12
2. The contextual character of works of art and architecture is discussed in H.-G. Gadamer, *Wahrheit und Methode*.
3. Zevi, B., *Poetica dell'architettura neoplastica*. Milan 1953; Godoli, E., *Jan Wils, Frank Lloyd Wright and De Stijl*. Florence 1980.
4. Los, S., *Carlo Scarpa. Archietto Poeta*, op.cit Pg30
5. In his lectures and in the field Scarpa often described the disassociation of elements as his basic mode of approach in designing, cf. my monograph on Scarpa: *Carlo Scarpa. Architetto Poeta* (Venice 1967). As to the poetic side of his fragments, cf. Tafuri. *Opera Completa*. Milan 1984
6. Navalis maintained that in his opinion one should transcend many stages to perfect creation, and to be a writer one should spend a period as a teacher and as an artisan.
Junod, P., *Transparence e opacite*. Lausanne 1976.
7. Dal Co, F., >>Genie ist FleiB. < L'architettura du Carlo Scarpa << in *Carlo Scarpa. Opera completa*, op. cit.
8. Heidegger, M., *Die Kunst und der Raum*. St Gallen 1969.

Credits of Photographs

1. Pg. 2 a: Antonio Martinelli *Carlo Scarpa* Architecture and Urbanism 1985 p 100
2. Pg. 2 b: Klus Frahm *Carlo Scarpa* Benedikt Taschen 1993 p 18
3. Pg. 3 a: Antonio Martinelli *Carlo Scarpa* Architecture and Urbanism 1985 p 154
4. Pg. 3 b: Antonio Martinelli *Carlo Scarpa* Architecture and Urbanism 1985 p 156
5. Pg. 4 a: Maurizio Brenzoni *Carlo Scarpa* :Architecture in Details 1988 p 247
6. Pg. 4 b: Klus Frahm *Carlo Scarpa* Benedikt Taschen 1993 p 18
7. Pg. 4 c: Antonio Martinelli *Carlo Scarpa* Architecture and Urbanism 1985 p 119
8. Pg. 4 d: Don Flick *Student of Architecture* V.Tech
9. Pg. 5 a: Stefan Buzas, London *Carlo Scarpa* :Architecture in Details 1988 p 60
10. Pg. 5 b: Antonio Martinelli *Carlo Scarpa* Architecture and Urbanism 1985 p 171
12. Pg. 6 a: Antonio Martinelli *Carlo Scarpa* Architecture and Urbanism 1985 p 91
13. Pg. 6 b: Klus Frahm *Carlo Scarpa* Benedikt Taschen 1993 p 138
14. Pg. 7 a: Maurizio Brenzoni *Carlo Scarpa* :Architecture in Details 1988 p 114
15. Pg. 7 b: Sandro Bagnoli *Carlo Scarpa* :Architecture in Details 1988 p 24
16. Pg. 8 b: Antonio Martinelli *Carlo Scarpa* Architecture and Urbanism 1985 p 91
17. Pg. 9 a: Antonio Martinelli *Carlo Scarpa* Architecture and Urbanism 1985 p 114
18. Pg. 9 b: Antonio Martinelli *Carlo Scarpa* Architecture and Urbanism 1985 p 122
19. Pg. 9 c: Don Flick *Student of Architecture* V.Tech
20. Pg. 10 a: Klus Frahm *Carlo Scarpa* Benedikt Taschen 1993 p 133
21. Pg. 10 b: Antonio Martinelli *Carlo Scarpa* Architecture and Urbanism 1985 p 173
22. Pg. 10 c: Antonio Martinelli *Carlo Scarpa* Architecture and Urbanism 1985 p 175
23. Pg. 11 a: Antonio Martinelli *Carlo Scarpa* Architecture and Urbanism 1985 p 105
24. Pg. 11 b: Klus Frahm *Carlo Scarpa* Benedikt Taschen 1993 p 146
25. Pg. 11 c: Maurizio Brenzoni *Carlo Scarpa* :Architecture in Details 1988 p 114
26. Pg. 11 d: Antonio Martinelli *Carlo Scarpa* Architecture and Urbanism 1985 p 91

I dedicate this thesis to my family for their love and support through entire life.

Thanks to all my classmates, all who participated and made entire project possible.

Special thanks to my committee: Michael O Brien, William Green, Dennis Kilper, Heinrich Schnoedt for their time and dedication. Thanks to Bill Sevebeck and Buddy Shaver for their help in metal shop. I will miss you all.

VITA

Kartikey Patel
February 25 1972

1989-1995
Bachelor of Architecture
Institute of Environmental Design
Gujarat, India

1997-1999
Virginia Polytechnic Institute and
State University
Master of Architecture

