

# **A Proactive Routing Protocol for Multi-Channel Wireless Ad-hoc Networks**

Unghee Lee

Dissertation submitted to the faculty of the  
Virginia Polytechnic Institute and State University  
in partial fulfillment of the requirements for the

Doctor of Philosophy  
In  
Computer Engineering

Dr. Scott F. Midkiff, Chair  
Dr. Charles W. Bostian  
Dr. Ing Ray Chen  
Dr. Luiz A. DaSilva  
Dr. Yiwei Thomas Hou

June 14, 2006  
Blacksburg, Virginia

Keywords: Multiple-channel, MANET, Ad-hoc, Multiple Interfaces,  
DSDV-MC, OSPF-MCDS-MC, OLSR-MC,  
Channel Selection Algorithm, Virtual Interface Module

Copyright 2006, Unghee Lee

# **A Proactive Routing Protocol for Multi-Channel Wireless Ad-hoc Networks**

Unghee Lee

Dr. Scott F. Midkiff, Chair

Computer Engineering

## **Abstract**

Wireless mobile ad-hoc networks consist of a collection of peer mobile nodes that form a network and are capable of communicating with each other without help from stationary infrastructure such as access points. The availability of low-cost, commodity network interface cards (NICs) has made the IEEE 802.11 medium access control (MAC) protocol the *de facto* MAC protocol for wireless mobile ad-hoc networks, even though it is not optimal. The IEEE 802.11 MAC protocol is designed to have stations share a single channel in a given network. However, many of the IEEE 802.11 physical (PHY) layer specifications define multiple channels and allow the simultaneous, non-interfering use of some of these channels. Therefore, multiple communications can occur at the same time, offering the opportunity to increase the effective network capacity.

We present an innovative routing protocol that utilizes multiple channels to improve the performance of wireless ad-hoc networks. The basic idea of the protocol is to use multiple channels so that multiple useful transmissions can occur simultane-

ously, thus increasing network capacity. The proposed scheme requires minor changes to existing proactive ad-hoc routing protocols and no modifications to the current IEEE 802.11 MAC protocol. To reduce inefficiencies due to periodic updates in the proactive routing protocols, the proposed scheme divides the network layer into control and data planes. Nodes send routing updates using the control channel and user packets using the data channel.

To demonstrate the multi-channel routing scheme, we extend the Destination-Sequenced Distance-Vector (DSDV), Open Shortest Path First-Minimal Connected Dominating Set (OSPF-MCDS), and Optimized Link State Routing (OLSR) protocol to multiple channel (MC) versions, denoted as DSDV-MC, OSPF-MCDS-MC, and OLSR-MC, respectively. Simulation results for DSDV-MC, OSPF-MCDS-MC, and OLSR-MC are presented and experimental results for OLSR-MC are presented. Simulation results indicate that DSDV-MC and OSPF-MCDS-MC effectively exploit multiple channels to improve network capacity. Goodput, the throughput considering only useful error-free packets, increases with an increased number of available channels as the number of nodes and network load increase in both single-hop and multiple-hop networks. Experimental results with OLSR-MC also support that the proposed scheme increases network capacity without modification to the MAC protocol in a real implementation.

Although simulation and experimental results show that proposed scheme improves network capacity by exploiting multiple channels, problems exist with channel distribution. We introduce a new metric, the Channel Distribution Index (CDI) to investigate these issues. The CDI indicates the fairness of the channel distribution. We identify the channel convergence problem, where a particular channel is over-

utilized, and propose a channel reallocation scheme to mitigate the impact of the channel convergence problem using the CDI.

*To my wife, Sohyun Kim and family*

## **Acknowledgements**

It is difficult for me to know where to begin thanking people for their help. The work done in Virginia Tech was made possible by the personal contributions of a variety of individuals to whom I am greatly indebted. I would like to take the opportunity to thank the many people who guided and supported me during this process.

My sincere appreciation goes to my academic advisor, Dr. Scott F. Midkiff for his guidance, patience, and support. He has not only been my academic advisor but also a mentor throughout my studies at Virginia Tech. I feel lucky that I have been doing my doctoral studies under his supervision. I am also thankful to my committee members, Dr. Charles W. Bostian, Dr. Ing-Ray Chen, Dr. Yiwei Thomas Hou, and, especially, Dr. Luiz A. DaSilva for their time and comments on my work.

I would like to express my sincere appreciation to the many people in the research laboratory, Michael, Aniket, Michelle, Tao, Fahad, and Vijay. I would especially like to thank my very special friends, Otis and Rutger, who have accompanied me throughout my doctoral journey. They have always been there when I needed them. Without their support and patience, I could not have succeeded in my research as well as my life at Virginia Tech. I would also like to thank George for his help in successfully finishing my project. I will always remember the time we had together and wish them all success in their careers and happiness in their lives.

Last, but not least, I think the most my wife, Sohyun Kim, who contributed

much through her patience and support during my studies. She was always with me listening to me. Without her love, support, and encouragement, the work would not have been possible.

This work was supported in part by funding from the U.S. Office of Naval Research (ONR) through the Navy Collaborative Integrated Information Technology Initiative (NAVCIITI) and the Advanced Wireless Integrated Navy Network (AWINN) projects. I was also supported during my Ph.D. studies through projects funded by Intel and Boeing Satellite Systems. This support is gratefully acknowledged. My time at Virginia Tech has included personal strife and enjoyment. With this degree completed, I move on to further build my career in research and development in industry, which I have been eagerly awaiting.

# Contents

<b>Chapter 1 Introduction.....</b>	<b>1</b>
<b>Chapter 2 Background and Related Work .....</b>	<b>7</b>
2.1 The IEEE 802.11 Standard.....	8
2.1.1 MAC Layer.....	10
2.1.2 Types of Networks.....	12
2.2 Mobile Ad-Hoc Network (MANET) Routing Protocols .....	16
2.2.1 Reactive Routing Protocols .....	17
2.2.2 Proactive Routing Protocols.....	18
2.3 Related Work .....	24
2.3.1 MAC Approaches.....	25
2.3.2 Network Layer Approaches .....	33
2.3.3 Channel Assignment Algorithms .....	35
2.4 Summary .....	36
<b>Chapter 3 Problem Statement and Approach .....</b>	<b>38</b>
3.1 Advantages of Using Multiple Channels .....	39
3.1.1 Increased Capacity .....	39
3.1.2 Reduced Propagation Delay .....	40
3.1.3 Provision of Additional Services.....	40
3.2 Issues in a Multi-Channel Environment .....	41
3.2.1 Channel Synchronization .....	41
3.2.2 The Multi-Channel Hidden Terminal Problem .....	42
3.2.3 Number of Transceivers .....	44
3.2.4 Channel Assignment .....	45
3.2.5 Channel Use.....	47

3.2.6 Interface and Node Addressing.....	48
3.2.7 Busy Receiver .....	49
3.3 Proposed Approach to Multi-Channel Ad-hoc Networking.....	50
3.4 Methodology .....	53
3.5 Summary .....	55
<b>Chapter 4 Proactive Routing Protocols for Multiple Channels.....</b>	<b>56</b>
4.1 Assumptions .....	57
4.2 Design Principles.....	57
4.2.1 Channel Allocation.....	60
4.2.2 Delayed Initial HELLO Message .....	61
4.2.3 Channel Switch and Update for Communication.....	62
4.2.4 Advantages of the Proposed Scheme .....	63
4.2.5 Complexity Analysis.....	64
4.3 DSDV-MC: DSDV for Multiple Channels.....	65
4.3.1 Channel Assignment and New HELLO Message .....	66
4.3.2 Channel Switch .....	66
4.4 OSPF-MCDS-MC: OSPF-MCDS for Multiple Channels.....	67
4.4.1 New Hello Message.....	68
4.4.2 Channel Update (CU) Message .....	69
4.5 OLSR-MC: OLSR for Multiple Channels .....	69
4.5.1 New HELLO Message .....	70
4.5.2 Channel Update (CU) message .....	70
4.6 Proactive Routing Protocol Issues for Multiple Channel Networks.....	72
4.6.1 Efficiency.....	72
4.6.2 Channel Convergence Problem.....	73
4.6.3 Frequent Channel Switching .....	74
4.6.4 Power Saving.....	75
4.6.5 Asymmetric Links.....	76
4.6.6 Channel Errors .....	77
4.7 Summary .....	78
<b>Chapter 5 Channel Distribution .....</b>	<b>80</b>
5.1 Motivation.....	81
5.2 Channel Distribution Index (CDI) .....	82
5.2.1 Required Properties of the CDI.....	83

5.2.2 Definition of the CDI.....	85
5.2.3 Continuity Analysis for CDI.....	86
5.3 Channel Reallocation.....	88
5.3.1 Simulations with Random Transmission .....	89
5.3.2 Simulations with Channel Convergence.....	90
5.3.3 Channel Reallocation .....	93
5.4 Summary .....	96
<b>Chapter 6 Simulation Experiments and Results .....</b>	<b>98</b>
6.1 Modifications to the Node Model Object .....	98
6.2 Simulation Experiments .....	102
6.3 Results for DSDV-MC.....	103
6.3.1 Results for Single-Hop Networks.....	103
6.3.2 Results for Multiple-Hop Networks.....	107
6.3.3 Results for the Channel Reallocation Procedure .....	110
6.4 Results for OSPF-MCDS-MC .....	119
6.4.1 Results for Single-Hop Networks.....	119
6.4.2 Results for Multiple-hop Networks .....	125
6.5 Discussion.....	129
6.6 Summary .....	132
<b>Chapter 7 Implementation and Experimental Results.....</b>	<b>134</b>
7.1 OLSR-MC Module .....	135
7.1.1 Communication with the Virtual Interface Module .....	135
7.1.2 New Format for HELLO and Channel Update Messages .....	136
7.1.3 Delayed Initial HELLO Message .....	137
7.2 Virtual Interface Module .....	137
7.2.1 Design Approach .....	138
7.2.2 User Data Flow.....	139
7.2.3 Neighbor Table.....	141
7.2.4 VIM Functions .....	141
7.3 Implementation Issues.....	142
7.3.1 Multiple-hop Networks .....	143
7.3.2 Number of Virtual Interfaces .....	143
7.3.3 Address Resolution.....	145
7.3.4 Routing Table Manipulation.....	146

7.4 Experimental Results for OLSR-MC.....	148
7.5 Summary .....	153
<b>Chapter 8 Conclusions and Future Work.....</b>	<b>154</b>
8.1 Summary .....	154
8.2 Contributions .....	158
8.3 Future Directions .....	160
<b>Appendix A</b>	<b>162</b>
<b>Appendix B</b>	<b>166</b>
<b>Appendix C</b>	<b>168</b>
<b>Bibliography</b>	<b>170</b>
<b>Curriculum Vitae</b>	<b>177</b>

# List of Figures

<b>Figure 2.1:</b> An illustration of terms used in this dissertation. ....	8
<b>Figure 2.2:</b> Example of an infrastructure network. ....	14
<b>Figure 2.3:</b> Example of an independent basic service set network. ....	15
<b>Figure 2.4:</b> Example of an extended service set (adapted from [8]). ....	16
<b>Figure 3.1:</b> Channel synchronization problem. ....	42
<b>Figure 3.2:</b> Hidden terminal problem under multi-channel networks. ....	43
<b>Figure 3.3:</b> NAV setting for a burst of fragments. ....	44
<b>Figure 3.4:</b> Methodology. ....	54
<b>Figure 4.1:</b> Control and data planes at a node with two transceivers. ....	59
<b>Figure 4.2:</b> Pseudocode for the channel assignment procedure. ....	61
<b>Figure 4.3:</b> DSDV-MC HELLO message. ....	66
<b>Figure 4.4:</b> New OSPF-MCDS-MC HELLO message. ....	68
<b>Figure 4.5:</b> OSPF-MCDS-MC CU message. ....	69
<b>Figure 4.6:</b> OLSR-MC HELLO message. ....	71
<b>Figure 4.7:</b> OLSR-MC CU message. ....	71
<b>Figure 4.8:</b> Illustration of the channel convergence problem. ....	74
<b>Figure 4.9:</b> Illustration of the frequent channel switching problem. ....	75
<b>Figure 4.10:</b> Asymmetric ranges for the control and data channel. ....	77
<b>Figure 4.11:</b> Illustration of CU message loss. ....	78
<b>Figure 5.1:</b> Illustration of the continuity of the CDI. ....	87
<b>Figure 5.2:</b> Comparison the CDI and Jain, Chiu, and Hawe’s fairness index. ....	88
<b>Figure 5.3:</b> Channel distribution index after random exchanges. ....	90
<b>Figure 5.4:</b> Example wireless sensor network architecture. ....	91
<b>Figure 5.5:</b> CDI values indicating the channel convergence problem. ....	92
<b>Figure 5.6:</b> Pseudocode for the channel reassignment procedure. ....	94
<b>Figure 6.1:</b> Schematic of a MobileNode object in ns2 [67]. ....	100
<b>Figure 6.2:</b> Schematic of the modified MobileNode object. ....	101
<b>Figure 6.3:</b> Goodput for single-hop network with varying numbers of nodes. ....	105
<b>Figure 6.4:</b> Packet drop rate for single-hop network with varying numbers of nodes. ....	105

<b>Figure 6.5:</b> Routing packets for single-hop network with varying numbers of nodes...	106
<b>Figure 6.6:</b> Goodput for single-hop network with varying packet size. ....	106
<b>Figure 6.7:</b> Goodput for single-hop network with varying packet arrival rate. ....	107
<b>Figure 6.8:</b> Goodput for varying packet arrival rates for a stationary multiple-hop network. ....	108
<b>Figure 6.9:</b> Goodput for varying packet arrival rates for a mobile multiple-hop network. ....	109
<b>Figure 6.10:</b> Number of routing messages for varying numbers of nodes.....	109
<b>Figure 6.11:</b> Number of routing messages for varying numbers of nodes.....	110
<b>Figure 6.12:</b> CDI for linear network for varying numbers of nodes.....	113
<b>Figure 6.13:</b> Goodput for linear network for varying numbers of nodes.....	113
<b>Figure 6.14:</b> CDI for the single-hop network for varying numbers of nodes. ....	115
<b>Figure 6.15:</b> Goodput for the single-hop network for varying numbers of nodes. ....	115
<b>Figure 6.16:</b> CDI for multi-hop network for varying numbers of nodes. ....	117
<b>Figure 6.17:</b> Goodput for multiple-hop network for varying numbers of nodes. ....	118
<b>Figure 6.18:</b> Goodput for multiple-hop network for varying reference index. ....	118
<b>Figure 6.19:</b> Frequency of channel reallocation in a multiple-hop network.....	119
<b>Figure 6.20:</b> Goodput for single-hop network for varying numbers of nodes. ....	122
<b>Figure 6.21:</b> Packet drop rate for single-hop network for varying numbers of nodes. ..	122
<b>Figure 6.22:</b> Routing messages for single-hop network .....	123
<b>Figure 6.23:</b> RMR for single-hop network .....	123
<b>Figure 6.24:</b> Goodput for single-hop network for varying packet size.....	124
<b>Figure 6.25:</b> Goodput for single-hop network for varying packet arrival rate.....	124
<b>Figure 6.26:</b> Goodput for stationary multiple-hop network.....	126
<b>Figure 6.27:</b> Goodput for mobile multiple-hop network for different packet arrival rates. ....	126
<b>Figure 6.28:</b> Number of routing messages for stationary multiple-hop network.....	127
<b>Figure 6.29:</b> Number of routing messages for a mobile multiple-hop network.....	127
<b>Figure 6.30:</b> Goodput for stationary multiple-hop network.....	128
<b>Figure 6.31:</b> Goodput for mobile multiple-hop network for varying numbers of nodes.	128
<b>Figure 6.32:</b> Goodput gain for varying numbers of channels. ....	130
<b>Figure 6.33:</b> Control overhead for varying numbers of channels. ....	131
<b>Figure 6.34:</b> Drop rate for varying numbers of channels.....	131
<b>Figure 7.1:</b> Signaling between OMM and the VIM. ....	136
<b>Figure 7.2:</b> Data flow through the VIM. ....	138
<b>Figure 7.3:</b> Illustration of data flow. ....	140

<b>Figure 7.4:</b> Multiple virtual interface scheme.....	145
<b>Figure 7.5:</b> Format of routing table entries .....	147
<b>Figure 7.6:</b> Maximum throughput for varying arrival rate. ....	151
<b>Figure 7.7:</b> Throughput with varying packet size. ....	152
<b>Figure 7.8:</b> Data rate for routing messages for different numbers of nodes. ....	152

## List of Tables

<b>Table 7-1:</b> Messages between the OMM and VIM. ....	136
<b>Table C-1:</b> IEEE 802. 11b PHY Characteristics.....	169

# Chapter 1 Introduction

Wireless mobile ad-hoc networks consist of a collection of peer mobile nodes that form a network and are capable of communicating with each other without help from stationary infrastructure such as access points. Nodes within each other's radio range communicate directly via wireless links, while out-of-range nodes use other nodes as intermediate routers to forward packets through multiple-hop routing. Such mobile ad-hoc networks are useful in any situation where temporary or rapid network formation is needed, such as in response to a natural disaster, on the battlefield, or in a conferencing scenario. The mobile ad-hoc network (MANET) concept is also important in realizing multi-hop mesh networks, such as for cost-effective metropolitan wireless network deployments.

Multi-hop ad-hoc wireless networks have several characteristics that differ from traditional wired networks. First, any collection of capable nodes within transmission range can form a network and start communicating after a synchronization process since ad-hoc networks do not require an access point or other infrastructure. Second, wireless channel capacity is a scarce and shared resource. As described in the IEEE 802.11 standard [1], the wireless medium does not have absolute or easily observable boundaries

that limit the reception of transmitted frames and the wireless channel is not protected from outside signals. In addition, communication over a wireless medium is significantly less reliable than over a wired medium and has time-varying and asymmetric propagation properties. Third, the network topology can change dynamically due to the movement of mobile nodes, which may lead to sudden packet losses and delays and the need to establish new routes. Finally, mobile nodes often have limited energy resources since they are usually powered by batteries [1].

The availability of low-cost, commodity network interface cards (NICs) has made the IEEE 802.11 medium access control (MAC) protocol the *de facto* MAC protocol for wireless mobile ad-hoc networks, even though it is not optimal. The IEEE 802.11 MAC protocol utilizes carrier-sense multiple access with collision avoidance (CSMA/CA) and channel reservation via the Network Allocation Vector (NAV). The IEEE 802.11 MAC protocol is designed to have stations share a single channel in a given network. The various IEEE 802.11 physical (PHY) layer protocols do allow separate networks to use different channels, but the MAC layer uses a single logical channel provided by the PHY. Since a single channel is used for a network, the MAC protocol is likely to face significant throughput degradation as the number of active nodes and the load increases. An important performance limitation is the so-called “exposed terminal” problem where concurrent transmissions cannot take place when two senders hear each other, even though the respective receivers do not hear any node other than their associated sender [2]. In addition, collisions and the associated backoff scheme in the IEEE 802.11 MAC protocol can waste bandwidth as traffic increases. Since tight synchronization is not practical in a large-scale multi-hop ad-hoc network, backoff delays are likely to be unsynchronized and a medium can be idle if all contending nodes are in

the backoff period.

Many of the IEEE 802.11 PHY specifications define multiple channels and allow the simultaneous, non-interfering use of some of these channels. For example, the IEEE 802.11b and IEEE 802.11g PHY standards provide three orthogonal channels. Twelve orthogonal channels are available in the IEEE 802.11a PHY standard. Therefore, multiple communications can occur at the same time to improve effective network capacity. The challenge, however, is to allow a single ad-hoc network to use the separate channels provided a PHY layer simultaneously in an efficient manner to increase effective capacity [3].

Several advantages are expected using multiple channels in wireless ad-hoc networks, such as increased throughput, reduced propagation delay, and the provision of additional services using multiple channels. In this dissertation, a new routing protocol is proposed to use multiple channels, e.g., realized at different frequencies, in a wireless multi-hop ad-hoc network by equipping nodes with multiple NICs. A complete multi-channel wireless ad-hoc network architecture requires topology discovery, traffic profiling, channel assignment, and routing [4].

The proposed proactive routing protocols, DSDV-MC, OSPF-MCDS-MC, and OLSR-MC, extensions of DSDV [5], OSPF-MCDS [6], and OLSR [7] respectively, provide not only a routing mechanism, but also a method to gather channel information to enable efficient channel assignment. One of the available channels is dedicated to control messages and the remaining one or more channels are used for data transfers. We consider in detail the case where each host is equipped with two transceivers, so that a host can listen on the control and data channel concurrently. Hosts exchange routing

messages, which include channel information through the control channel. We perform simulation experiments for both single-hop and multiple-hop networks to study performance and to verify the operation of the proposed protocol. Simulation results indicate that the proposed routing protocols provide the benefits of using multiple channels without modification to the current IEEE 802.11 MAC protocol. We also show that routing overhead is not significant because nodes use the common control channel to advertise routing information.

To verify the multi-channel routing scheme based on simulation results from DSDV-MC and OSPF-MCDS-MC, we extend the OLSR routing protocol to a multi-channel version, OLSR-MC and perform the experimental validation. The experimental results show that the network saturation point increases as the number of channel increases. In other words, network capacity increases as the number of channels increases. We also show that the number of routing messages with the multi-channel scheme is close to the single-channel case, although OLSR-MC requires additional overhead to advertise channel information as well as routing information.

Utilization of multiple channels in ad-hoc networks provides the benefits of increasing network capacity and increasing efficiency by reducing the probability of collisions. Multi-channel schemes are becoming more attractive as the cost of transceivers decreases and the capacity requirements for potential ad-hoc network applications increase. However, channel assignment mechanisms may distribute channels unfairly to different nodes, thus leading to inefficient use of available capacity and creating system bottlenecks. For this context, we present a new metric to explore channel distribution in multi-channel wireless ad-hoc networks. The approach lets each node measure the fair-

ness of channel distribution among neighboring nodes. Most prior work on multi-channel schemes focuses on the channel assignment (CA) problem and multi-channel multiple access control (MAC) protocols. Our proposed channel distribution index (CDI) measures the fairness of channel distribution and indicates the dynamic channel distribution among neighboring nodes. The proposed metric for multi-channel wireless ad-hoc networks can be used to evaluate the fairness of CA and MAC schemes and, in the future, to improve their efficiency.

To lessen the unfairness of channel distribution we propose a channel reallocation scheme. The channel reallocation scheme enables nodes to adapt to changes of the channel distribution according to the network topology and traffic characteristics. A node with the channel reallocation scheme enabled determines the channel unfairness through the channel distribution index (CDI) in a periodic manner. The reference index is used as a metric to judge fairness of channel resource allocation.

The remaining chapters are organized as follows. Chapter 2 presents background and summarizes past work. Chapter 3 defines problems related to using multiple channels and presents our approach. The new proactive routing protocols for multi-channel environment are presented in Chapter 4. The channel distribution problem and new metrics for multi-channel networks are discussed in Chapter 5. Simulation results are presented and discussed in Chapter 6. Implementation and experimental results that verify our multi-channel routing protocol are summarized in Chapter 7. Last, we summarize the results, cite our contributions, and discuss future research topics in Chapter 8. In addition, Appendix A has the list of acronyms, Appendix B presents the loadable kernel module for the virtual interface module, and Appendix C describes the calculation of

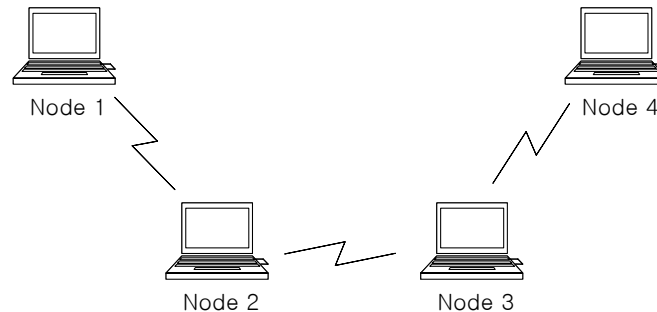
optimal data rate in 802.11b.

## Chapter 2 Background and Related Work

This chapter discusses the IEEE 802.11 standard and introduces wireless mobile ad-hoc networks that use the MAC and PHY layers of IEEE 802.11. It also describes examples of routing protocols that can support mobile ad-hoc networks. Routing protocols are characterized as being reactive or proactive. DSDV [5], OSPFMCDs [6], and OLSR [7], three proactive routing protocols are described in detail.

We define some terms before we use them in this document. A *node or STA* is a basic hardware/software unit in the network that has the capability to forward packets based on its local routing table. Examples include nodes 1, 2, 3, and 4 in Figure 2.1. A host is another basic unit in the network that may attach to or act as a node. A host can be either the source or the sink of a data flow in the network. In the example shown in Figure 2.1, two nodes, node 1 and node 4, are hosts in the example network. Network components refer to hosts and nodes in a network. A node  $M$  is said to be a neighbor of another node, say  $N$ , if there is a bidirectional link between  $M$  and  $N$ . We can also say that node  $M$  and  $N$  are neighbors. For example, node 2 and node 3 in Fig-

ure 2.1 are neighbors, and node 3 and node 4 are also neighbors. A route or path is a sequence of nodes connecting two end hosts within which any two adjacent nodes in the route or path are neighbors. For example, in Figure 2.1, a path between node 1 and node 4 contains node 2 and node 3.



**Figure 2.1:** An illustration of terms used in this dissertation.

A node can be equipped with multiple NICs to access multiple radio channels. This configuration can provide separation of two main types of traffic in the wireless domain. While nodes can exchange routing and configuration information using one radio channel, nodes can transmit data out on a different radio channel. A channel, also referred to as a transmission channel, is a transmission path between two directly connected nodes in a network over which frames can be transmitted. A radio channel is a band of adjacent frequencies having sufficient bandwidth to permit its use for radio communication.

## 2.1 The IEEE 802.11 Standard

The IEEE 802.11 standard covers the MAC and PHY layers. In 1997, the IEEE adopted IEEE Standard 802.11-1997, the Wireless Local Area Network (WLAN) standard [1].

This standard defines the MAC and PHY layers for a local area network (LAN) with wireless connectivity. It addresses local area networking where the connected devices communicate over the air to other devices that are within close proximity to each other. The industry group Wireless Ethernet Compatibility Alliance (WECA) certifies its members' equipment as conforming to the IEEE 802.11b standard (and, recently, other specifications and standards) and enables compliant hardware to be certified as “Wi-Fi compatible.” This is an attempt to guarantee interoperability between thousands of devices from hundreds of vendors. The original IEEE 802.11 standard defines a single MAC that interacts with three physical layers; frequency hopping spread spectrum (FHSS) in the 2.4-GHz band, direct sequence spread spectrum (DSSS) in the 2.4-GHz band, and infrared (IR) [1].

The IEEE 802.11 wireless medium has the following characteristics. The IEEE 802.11 wireless medium has neither absolute nor readily observable boundaries outside of which nodes with conformant PHY transceivers are known to be unable to receive network frames. The wireless medium is unprotected from outside signals and has time-varying and asymmetric propagation properties. In addition, the communication over the IEEE 802.11 wireless medium significantly is less reliable than a wired medium. In terms of capacity, high-capacity wireless networks can be realized by assigning a single wide-band channel or by using multiple narrow-band channels. The IEEE 802.11 standard adopts the former approach in that it defines the MAC operations for a single channel. Mobile nodes in IEEE 802.11 often have limited energy resources since they are usually battery powered. Hence, power management is an important consideration and it affects the design of protocols.

### 2.1.1 MAC Layer

The MAC layer in the IEEE 802.11 standard defines two different access methods, the Distributed Coordination Function (DCF) and Point Coordination Function (PCF). The PCF is the basis for contention-free access to the wireless medium. Contention-free access is a centrally controlled, token-based scheme, where access points provide the "token" function. The PCF is restricted to infrastructure networks where an access point (AP) is present and mobile nodes communicate through the AP. Therefore, PCF cannot be used in ad-hoc networks. The basic access mechanism, DCF, is a CSMA/CA mechanism. Channel Access Method (CAM) protocols are well known, the most popular being Ethernet, which uses a carrier-sensing multiple access (CSMA) with collision detection (CSMA/CD) protocol [1, 8].

The CSMA protocol works as follows. A node desiring to transmit senses the medium. If the medium is busy, i.e., some other node is transmitting, the node defers its transmission to a later time. If the node senses the medium as being free, the node transmits. These kinds of protocols are effective when the medium is not heavily loaded, since it allows nodes to transmit with minimum delay. However, there is always a chance of two or more nodes simultaneously sensing the medium as free and transmitting at the same time, causing a collision. These collisions should be identified so that the MAC layer can retransmit the packets, as retransmission by upper layers would often cause significant delay. While collision detection is possible in a wired connection, it cannot be used for a wireless LAN.

In order to overcome this limitation, 802.11 uses Collision Avoidance (CA) mechanism coupled with a positive acknowledgement scheme as following. A node

wanting to transmit senses the medium. If the medium is busy, it defers transmission. If the medium is free for a specified time, as defined by the Distributed Inter-Frame Space (DIFS), the node is allowed to transmit [1, 8].

A receiving node checks the cyclic redundancy check (CRC) code of the received packet and sends an acknowledgment (ACK) packet. Receipt of the ACK indicates to the transmitter that no collision occurred. If the sender does not receive the ACK, it retransmits the frame until it receives the ACK or until it reaches a set number of maximum retransmissions, at which point the sender discards the packet (with possible later retransmission by the transport layer). According to the IEEE 802.11 standard, a maximum of seven retransmissions are allowed before the frame is dropped [1, 8].

To reduce the probability of two nodes colliding due to not hearing each other, which is the well known “hidden node problem,” the IEEE 802.11 standard defines a virtual carrier sensing (CS) mechanism. A node wanting to transmit a data packet first transmits a short control packet called a Request-To-Send (RTS) packet. This packet includes the source, destination, and duration of the intended packet stream and ACK transaction. The destination node responds, if the medium is free, with a response control packet called a Clear-To-Send (CTS), which includes the same duration information [1, 8].

All other nodes receiving either the RTS and/or the CTS set their virtual CS indicators, the Network Allocation Vector (NAV), for the given duration and use this information together with the physical CS when sensing the medium. The physical layer carrier sensing function is referred to as Clear Channel Assessment (CCA). The state of the NAV is checked in conjunction with the CCA to determine the current state of the me-

dium. This mechanism reduces the probability of a collision caused by a node that is “hidden” from the transmitter (and, thus, cannot hear the RTS or data packet), but is within radio range of the receiver. The “hidden” node would overhear the CTS and then “reserve” the medium as busy until the end of the transaction. The duration information of the RTS also protects the transmitter’s area from collisions during the ACK (from nodes that are out of range of the acknowledging node). It should also be noted that because RTS and CTS are short frames, the mechanism can also reduce the overhead added by collisions. This is due to the short transmissions allowing for faster recognition of collisions than would be possible for the transmission of an entire packet [1, 8].

### **2.1.2 Types of Networks**

The basic building block of an IEEE 802.11 network is the Basic Service Set (BSS), which is simply a group of nodes that communicate with each other. Communications take place within a basic service area, defined by the propagation characteristics of the wireless medium. When a node is in the basic service area, it can communicate with the other members of the BSS [1, 8].

#### **2.1.2.1 Infrastructure Networks**

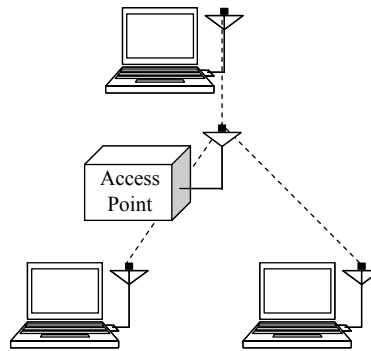
Infrastructure networks, as illustrated in Figure 2.2, are distinguished by the use of an access point. Access points are used for all communications in infrastructure networks, including communication between mobile nodes in the same service area. If a mobile node in an infrastructure BSS needs to communicate with a second mobile node, the communication must take two hops. First, the originating mobile node transfers the frame to the access point. Second, the access point transfers the frame to the destination

node. With all communications relayed through an access point, the basic service area corresponding to an infrastructure BSS is defined by the points in which transmissions from the access point can be received. Although the multi-hop transmission takes more transmission capacity than a directed frame from the sender to the receiver, it has two major advantages.

1. An infrastructure BSS is defined by the distance from the access point. All mobile nodes are required to be within reach of the access point, but no restriction is placed on the distance between mobile nodes themselves. Allowing direct communication between mobile nodes would save transmission capacity, but at the cost of increased physical layer complexity because mobile nodes would need to maintain neighbor relationships with all other mobile nodes within the service area.
2. Access points in infrastructure networks are in a position to assist nodes with some functions, such as attempting to save power or use security functions. Access points can detect when a node enters a power-saving mode and then buffer frames for it. Battery-operated nodes can turn the wireless transceiver off and power it up only to transmit and retrieve buffered frames from the access point. Access points also provide a location for node authentication and access control.

In an infrastructure network, nodes must associate with an access point to obtain network services. Association is the process by which a mobile node joins an IEEE 802.11 network; it is logically equivalent to plugging in the network cable on an Ethernet. It is not a symmetric process. Mobile nodes always initiate the association process and access points may choose to grant or deny access based on the contents of an association

request. Associations are also exclusive on the part of the mobile node; a mobile node can be associated with only one access point. The IEEE 802.11 standard places no limit on the number of mobile nodes that an access point may serve. Implementation considerations may limit the number of mobile nodes an access point may serve. In practice, however, the relatively low throughput of wireless networks is far more likely to limit the number of nodes placed on a wireless network [1, 8].

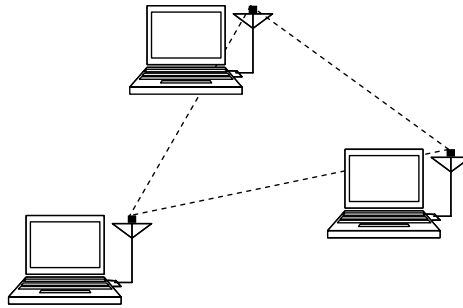


**Figure 2.2:** Example of an infrastructure network.

### 2.1.2.2 Independent Networks

Nodes in an Independent BSS (IBSS) communicate directly with each other and, thus, must be within direct communication range. The smallest possible IEEE 802.11 network is an IBSS with two nodes. Typically, IBSSs are composed of a small number of nodes set up for a specific purpose and for a short period. One common use is to create a short-lived network to support a single meeting in a conference room. As the meeting begins, the participants create an IBSS to share data. When the meeting ends, the IBSS is dissolved. Due to their short duration, small size, and focused purpose, IBSSs are

sometimes referred to as ad-hoc BSSs or ad-hoc networks [1, 8].



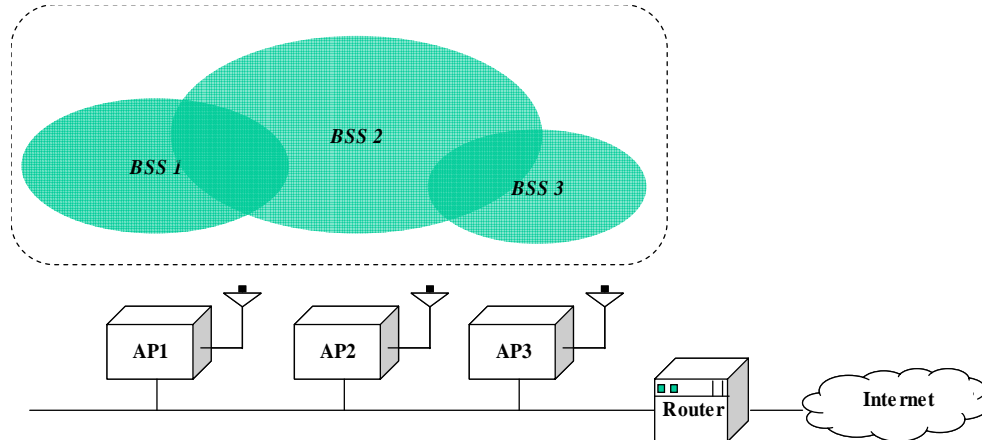
**Figure 2.3:** Example of an independent basic service set network.

### 2.1.2.3 Extended Service Areas

BSSs can create coverage in small offices and homes, but they cannot provide network coverage to larger areas. IEEE 802.11 allows wireless networks of arbitrarily large size to be created by linking BSSs to form an Extended Service Set (ESS). An ESS is created by chaining BSSs together with a backbone network. IEEE 802.11 does not specify a particular backbone technology; it requires only that the backbone provide a specified set of services. In practice, Ethernet is commonly used as the backbone network technology.

Nodes within the same ESS may communicate with each other, even though these nodes may be in different basic service areas and may even be moving between basic service areas. For nodes in an ESS to communicate with each other, the wireless medium must act like a single layer 2 connection. Access points act as bridges, so direct communication between nodes in an ESS requires that the backbone network also be a layer 2 connection. Any link layer connection will suffice. Several access points in a single area may be connected to a single hub or switch or they can use virtual LANs

(VLANs) if the link-layer connection must span a large area. IEEE 802.11 supplies link-layer mobility within an ESS, but only if the backbone network is a single link-layer domain, such as a shared Ethernet or a VLAN. This important constraint on mobility is often a major factor in IEEE 802.11 network design. Extended service areas are the highest-level abstraction supported by the IEEE 802.11 standard. Access points in an ESS operate in concert to allow the outside world to use a single MAC address to talk to a node somewhere within the ESS [1, 8].



**Figure 2.4:** Example of an extended service set (adapted from [8]).

## 2.2 Mobile Ad-Hoc Network (MANET) Routing Protocols

The routing mechanisms designed for wired networks are not adequate for ad-hoc networks due to their dynamic topology. To enable transmission between sender and receiver, the density of nodes should be high enough to provide connectivity [9]. Multi-hop routing protocols face the following two challenges. First, finding and choosing a

path from the source node to the destination node, given no initial information, is complex and requires some form of global flooding of the network. Second, nodes in an ad-hoc network are mobile and communication is unstable. As a result, it is costly to gather routing information and such information can become quickly out of date. MANET routing protocols to address these challenges have been the subject of a substantial amount of research over the past ten years or so. In general, these routing protocols for wireless ad-hoc networks can be classified as being either proactive (table-driven) or reactive (on-demand) [10].

### **2.2.1 Reactive Routing Protocols**

Reactive routing protocols, such as the Dynamic Source Routing (DSR) [11] and Ad-hoc On-demand Distance Vector (AODV) [12] routing protocols, are source-initiated on-demand routing protocols. This type of routing protocol creates routes only when requested by the source node. When a node requires a route to a destination, it initiates a route discovery process within the network. This process is completed once a route is found or all possible route permutations have been examined. Once a route is established, it is maintained by a route maintenance procedure either until the destination becomes inaccessible along every path from the source or until the route is no longer needed. This approach can adjust quickly to route changes and does not introduce overhead for periodic control messages when routes are cached or when the network is idle. However, discovering a new route “from scratch” on demand is costly and bad routes are detected at the cost of packet drops.

## 2.2.2 Proactive Routing Protocols

Proactive routing protocols, such as the Destination-Sequenced Distance-Vector (DSDV) [5], the Topology Broadcast Based on Reverse-Path Forwarding (TBRPF) [13] routing protocols, Optimized Link State Routing (OLSR) [7], and Open Shortest Path First with Minimum Connected Dominating Sets (OSPF-MCDS) [14], maintain up-to-date routing information using periodic control messages. Therefore, proactive routing protocols are ready to exchange packets at anytime. Each node using a proactive routing algorithm maintains one or more tables to store routing information and responds to changes in network topology by propagating updates throughout the network to maintain a consistent view of the network. The areas in which different protocols vary are the number of necessary routing-related tables and the methods by which nodes disseminate changes in network structure.

While this approach does not require global route discovery broadcasts, there are two main disadvantages. First, even when the network is idle, proactive protocols exhibit a certain amount of overhead for control messages. Second, proactive protocols are relatively slow to adjust to topology changes. To try to leverage the attractive features of both proactive and reactive routing protocols, hybrid protocols, such as SHARP [15], are proposed. Hybrid protocols use a proactive algorithm within local clusters of nodes and a reactive algorithm between clusters.

### 2.2.2.1 Destination-Sequenced Distance-Vector (DSDV) Protocol

DSDV [5] is a table-driven protocol based on the classical Bellman-Ford routing algorithm [16]. The improvements made to the Bellman-Ford algorithm include freedom

from loops in routing tables [5, 10]. Every mobile node in the network maintains a routing table that records all possible destinations within the network and the number of hops to each destination. Each entry is marked with a sequence number assigned by the destination node. The sequence numbers enable the mobile nodes to distinguish stale routes from new ones, thereby avoiding the formation of routing loops. Nodes periodically transmit routing table updates throughout the network to maintain consistent tables. To help alleviate the potentially large amount of network traffic that such updates can generate, route updates can employ two possible types of messages. The first is known as a “full dump.” This type of message carries all available routing information and can require multiple Network Protocol Data Units (NPDUs). During periods of occasional movement, these messages are transmitted infrequently. Smaller “incremental” messages are broadcast to provide only that information which has changed since the last full dump. Each of these messages should fit into a standard size NPDU, thereby decreasing the amount of traffic generated. The mobile nodes maintain an additional table where they store the data sent in the incremental routing information messages [5, 10].

New route broadcasts contain the address of the destination, the number of hops to reach the destination, the sequence number of the information received regarding the destination, as well as a new sequence number unique to the broadcast. The route labeled with the most recent sequence number is always used. In the event that two updates have the same sequence number, the route with the smaller metric is used to optimize (shorten) the path. Nodes also keep track of the settling time of routes, or the weighted average time that routes to a destination will fluctuate before the route with the best metric is received. By delaying the broadcast of a routing update by the length of the settling time, nodes can reduce network traffic and optimize routes by eliminating

those broadcasts that would occur if a better route was discovered in the near future [5, 10].

### **2.2.2.2 Open Shortest Path First with Minimum Connected Dominating Sets (OSPF-MCDS) Protocol**

The OSPF-MCDS routing protocol [6] is a table-driven, or proactive, protocol and regularly exchanges topology information with other nodes in network. The nodes selected as relay nodes form a Minimum Connected Dominating Set (MCDS) and only MCDS nodes rebroadcast control messages to reduce overhead of broadcast. Link state information is propagated through the network via MCDS nodes so that all nodes in network keep identical topology information. Dijkstra's algorithm [17] can be used to determine the shortest path to the destination. MCDS nodes are selected based on a heuristic algorithm and, as a set, cover all nodes in a network. Therefore, all nodes are guaranteed to receive propagated link state information via the MCDS nodes. The MCDS is used as the relay node set to replace the designated router concept used in the Open Shortest Path First (OSPF) routing protocol [6, 14, 18], which is widely used in traditional wired networks.

Nodes periodically broadcast HELLO messages to detect new neighbors and a time-out scheme is used to find expired neighbors if there is no HELLO message received from a neighbor for a certain period of time. OSPF-MCDS uses differential HELLO messages, which only include the Internet Protocol (IP) addresses of new neighbors. If the received HELLO message does not contain the receiver's node ID (Identifier), the sender's node ID is included in the receiver's next HELLO message. Otherwise, the receiver detects a new bi-directional link. In this case, if the sender has a

larger node ID, the sender's IP address will be included in the next HELLO message. If the sender has a smaller node ID, the receiver sends a Link UP Link State Description (LSD) message if there is no Link Database Description (LDD) message to be sent soon. After a two-way link is established between two neighbors, the neighbors' IP addresses are excluded from the HELLO messages.

Generally, when a new link comes up, the neighbor node with the largest ID sets the sequence number and sends a LSD message to declare the corresponding Link UP event. When an old link goes down, both end nodes inform other nodes about the Link DOWN event by sending a LSD message. Note that in the case of a link coming up, a neighboring node does not send the LSD message if there are only two nodes in its link state database. In other words, all known nodes in the network have the knowledge of this new link and there is no need to broadcast it. Similarly, in the case of a link down event, a neighboring node of that link does not send a LSD message if there is no neighboring node in its neighbor list. Note that if a period LDD message is going to be sent soon, the LSD Link UP message is not generated or forwarded. If the LSD describes a link down event, it is forwarded by MCDS nodes to guarantee that no node uses this broken link in its shortest path tree. In the case of a link state change, the shortest paths to all destinations are recalculated [6].

There is a counter associated with the HELLO protocol. When a HELLO message is sent, the counter is increased by one. When the counter reaches a predefined maximum value, say three, the counter is reset and the node also sends a periodic broadcast of its local link state database. When the counter is one less than the predefined maximum value, the node is going to broadcast link state database "soon." In this case,

there is no LSD Link UP message to be forwarded or sent by this node because the LSD Link UP message is included in the next periodic control message scheduled in a short time [6].

An MCDS node broadcasts its neighbor list and full copy of its local link state databases using LDD messages. MCDS nodes also increase the sequence numbers of neighboring edges that connect to neighbors with small IDs. Note that a neighbor node is not added into the LDD message if the counter for that neighbor is one less than the maximum allowed missing HELLO messages. Similarly, if the counter for an edge is one less than the maximum allowed missing synchronization, this edge is excluded from the corresponding LDD message. When a node receives an LDD message, the sequence number of each link state description in this message is checked with the local copy. If the received message has a later (higher) sequence number, the local link state is updated. If there is no local copy for one link entry, this link is considered a new link and processed as if a LSD Link UP message is received.

Similar to the counter used for neighbors, there is also a counter for each edge. If an edge is refreshed by a LDD message, i.e., the received link state entry is more recent than the local copy, the counter is reset to zero. Each time when a node generates a periodic broadcast message, the counters for all edges are increased by one. If the counter for a link reaches the maximum allowed value, this edge expires in the local link state database. If any link expires before the generation of the next broadcast message, the MCDS is re-selected and the shortest paths to all possible destinations are recalculated [6].

### 2.2.2.3 Optimized Link State Routing (OLSR) Protocol

OLSR is a proactive routing protocol for mobile ad hoc networks, i.e., it regularly exchanges topology information with other nodes in the network. The protocol inherits the stability of a link state algorithm and has the advantage of having routes immediately available when needed due to its proactive nature. OLSR is an optimization over the classical link state protocol, tailored for mobile ad hoc networks [7].

OLSR minimizes the overhead from flooding of control traffic by using only selected nodes, called multipoint relays (MPR), to retransmit control messages. Each node selects a set of its neighbor nodes as MPR. Only nodes selected MPRs are responsible for forwarding control traffic intended for propagation to the entire network. MPRs provide an efficient mechanism for flooding control traffic by reducing the number of transmissions required. MPR nodes also have a special responsibility when declaring link state information in the network. Indeed, the only requirement for OLSR to provide shortest path routes to all destinations is that MPR nodes declare link state information for their MPR selectors. Additional available link state information may be utilized, e.g., for redundancy [7].

Nodes that have been selected as multipoint relays by at least one neighbor node announce this information periodically in their control messages. Thus, a node announces to the network that it can reach nodes that have selected it as an MPR. In route determination, the MPRs are used to form the route from a given node to any destination in the network. Furthermore, OLSR uses the MPRs to facilitate efficient flooding of control messages in the network. A node selects MPRs from among its one-hop neighbors with symmetric, i.e., bi-directional, links. Therefore, selecting the route

through MPRs automatically avoids the problems associated with data packet transfer over unidirectional links, such as not getting link layer acknowledgments for data packets at each hop for link layers employing this technique for unicast traffic. The protocol is particularly well suited for large and dense networks, as the optimization done using MPRs works well in this context. The larger and more dense a network, the more optimization can be achieved as compared to the classic link state algorithm. [7].

OLSR is designed to work in a completely distributed manner and does not depend on any central entity. The protocol does not require reliable transmission of control messages; each node sends control messages periodically and can, therefore, sustain a reasonable loss of some such messages. Such losses occur frequently in radio networks due to collisions or other transmission problems.

Also, OLSR does not require sequenced delivery of messages. Each control message contains a sequence number that is incremented for each message. Thus, the recipient of a control message can, if required, easily identify which information is more recent even if messages have been re-ordered while in transmission.

## **2.3 Related Work**

There have been many research efforts focusing on multi-channel schemes for ad-hoc networks in the past few years. Multi-channel schemes can be broadly categorized according to the different layer's perspective, MAC versus Network layer. Prior research on multi-channel MAC protocols is based on IEEE 802.11. Most proposed multi-channel MAC protocol schemes require modifications to IEEE 802.11's MAC mechanism, and, therefore, cannot be deployed using commodity hardware.

In contrast, prior research from the network layer's perspective is performed to make use of standard IEEE 802.11 interfaces. These two approaches are described below. Following the MAC and network layer schemes, the channel assignment schemes are discussed. Channel assignment is the one of the key factors for a complete multi-channel wireless ad-hoc network architecture and should be distributed due to the ad-hoc nature of the networks of interest.

### **2.3.1 MAC Approaches**

Previously proposed multi-channel MAC schemes require changes to the MAC and new hardware. For synchronization and communication between nodes, nodes need to share control messages among nodes for the channel reservation or negotiation. Neighboring nodes might use a common control channel or a common time period to exchange control information. We categorize the related research on MAC layer approaches according to the number of transceivers.

#### **2.3.1.1 Single Transceiver Approaches**

Since only a single transceiver is used by each node for this scheme, the cost and compatibility are the primary advantages compared to multiple transceiver approaches. Only one channel is active at a time from each node since a single transceiver is used, and different nodes communicate through different channels simultaneously to increase network capacity. Coordination of channel synchronization between nodes is required under this situation.

Chen, Sheu, and Yang [3] proposed a new CSMA based protocol, called the Multi-channel Access Protocol (MAP), to support parallel transmissions by a single transceiver

in IEEE 802.11 ad-hoc WLANs. The channel access is partitioned as two alternative and non-overlapping time intervals: the Contention Reservation Interval (CRI) and the Contention Free Interval (CFI). Mobile nodes use a dedicated contention channel to contend with other nodes to reserve data slots. All of the other channels serve permanently as data channels. During CRI, nodes contend to exchange RTS and CTS frames with channel information. The successful sender and receiver switch to one of available channels according to the Channel Scheduling Algorithm (CSA) and exchange packets during the CFI. The interval information for CRI and CFI is delivered using the Beacon frame since all nodes in a network should share the interval information. However, since beacon frames are delivered in a distributed manner in ad-hoc networks, it is hard for nodes to be correctly synchronized.

Li, Haas, Sheng, and Chen [19] propose a modified IEEE 802.11 MAC protocol for multiple channels that includes a new channel-status indicator. One channel is designated as the common control channel and the other channels are data channels. Data packets and the associated acknowledgement packets are transmitted through the traffic channel. Nodes exchange RTS and CTS frames with channel information through a common control channel to make the traffic channel reservation for transmission of data packets. After successful exchange of channel negotiation, nodes change the working channel to the channel they negotiated. Nodes reside on the common access control channel, except when they transmit data on one of the traffic channels. Other nodes listening to the common control channel set their NAV and defer transmissions to the node that is transmitting or receiving. Nodes are assumed to be equipped with half-duplex radio transceiver and it is assumed that the transceiver can be tuned to different channels. With a single transceiver, nodes must be synchronized to switch between the common

control channel and data channel at the correct time. Otherwise, the hidden terminal problem can occur, so that nodes are not able to listen to the RTS/CTS exchange from other nodes. This will break all functions of the proposed mechanism.

Bahl, Chandra, and Dunagan [20] propose Slotted Seeded Channel Hopping, or SSCH, that increases the capacity of an IEEE 802.11 network by utilizing frequency diversity. However, they change channel assignment in a fast time scale on a per-packet basis that may not work with existing commodity hardware. Unlike other multi-channel MAC scheme, SSCH does not require modifications to the IEEE 802.11 MAC itself since SSCH works on top of IEEE 802.11 MAC.

Wiwatthanasaranrom and Phonphoem [21] propose a Multi-channel MAC (MMAC) protocol that utilizes multiple channels. Each node in the protocol negotiates channel assignments during IEEE 802.11's Announcement (Ad-hoc) Traffic Indication Message (ATIM) window, which occurs at a fixed time after the beacon. The protocol requires only a single transceiver at each host and a separate common control channel. After successful channel negotiation during the ATIM window, nodes switch to the negotiated channel and exchange messages on the channel for the rest of the beacon interval. Each host periodically sends out beacons to synchronize time in a distributed manner as in IEEE 802.11's power saving mechanism. However, the time multiplexed control channel requires clock synchronization among all nodes in a network, which is difficult in large multiple-hop ad-hoc networks due to their dynamic nature.

So and Vaidya [22] propose a MAC protocol that enables nodes to negotiate channels dynamically so that multiple communication flows can occur in the same region simultaneously. The main idea of this work is the same as Wiwatthanasaranrom and

Phonphoem's scheme [21] in that every node listens on a common channel to negotiate channels in the ATIM window at the start of each beacon interval.

The MultiNet scheme proposed by Chandra, Bahl, and Bahl [23] facilitates simultaneous connections to multiple networks using different channels or different Service Set Identifiers (SSIDs) by "virtualizing" the single wireless card. Application scenarios for MultiNet include bridging network infrastructure, ad-hoc networks, and increasing network range. A limitation of the current IEEE 802.11 standard is that one node cannot interact with another node in a different network. Further, a node in an ad-hoc network cannot interact with a node in an infrastructure network even though they use the same channel. MultiNet enables a node to access multiple channels and networks simultaneously in a manner that is transparent to the user. While the authors present a new architecture and algorithms that show how to access multiple channels and networks almost simultaneously, the issues regarding how to use multiple channels and networks for ad-hoc multiple-hop networks are not discussed. Switching algorithms are proposed to determine how long a node stays at one channel among multiple possible channels. However, these algorithms are based on one-hop information. Thus, the MultiNet scheme should consider extensions or additional algorithms to account for multi-hop connections for multiple-hop networks.

### **2.3.1.2 Multiple Transceiver MAC Approaches**

In this approach, a node has multiple transceivers each with its own MAC and physical layers. Therefore, communications and accessing the medium in these transceivers are independent. Since nodes are allowed to switch channels dynamically, coordination of channel synchronization and communication between nodes are necessary.

Hung, Law, and Leon-Garcia [24] propose a new MAC protocol, Dynamic Private Channel (DPC), which uses multiple channels in an ad-hoc network to solve two problems, connectivity and load balancing, while maintaining good performance. These two potential problems can occur when current IEEE 802.11 MAC protocol is applied to multi-channel environments. DPC is connection oriented. Two mobile nodes (transmitter and receiver) negotiate the channel by exchanging RTS, Reply to RTS (RRTS), and CTS messages through a multicast Control Channel (CCH) before data exchange. Once a unicast Data Channel (DCH) is assigned to a transmitter-receiver pair, this channel is not shared anymore. The communication ends either when they have no more data to exchange or when the reservation period expires. As acknowledged in [24], the blocking effect in DPC has a significant impact on performance. In addition, different blocking problems can occur if a node has multiple connections since a single transceiver is dedicated to a DCH.

Jain, Das, and Nasipuri [25] propose a multi-channel CSMA MAC protocol, which uses one control channel and  $N$  data channels. Nodes exchange control packets on the control channel to negotiate the best channel for the receiver's data channel. However, Jain, Das, and Nasipuri do not specify how many physical transceivers are required at a node. Based on the assumption that nodes can simultaneously sense carrier on the entire set of channels for incoming transmissions, it is implied (using existing technology) that  $N$  physical transceivers are required at each node for  $N$  data channels. This scheme significantly increases the hardware complexity. In addition, since the destination node creates its own free-channel list by sensing the carrier on all data channels, the delay of changing channels is not negligible even though the delay in channel switching can be reduced using new technology [26].

Wu, et al. [27] propose the Dynamic Channel Assignment (DCA) protocol, which assigns channels dynamically in an on-demand manner. DCA assigns one channel for control messages and uses other channels for data. Each host has two transceivers so that it can listen on the control and data channel simultaneously. RTS and CTS frames are exchanged on the control channel and the data channel is assigned through the exchange of RTS and CTS messages. This protocol does not require synchronization. However, as the number of available data channel increases, the bottleneck in the control channel due to per packet channel negotiation prevents full utilization of data channels.

Pathamasuntharam, Das, and Gupta [28] propose the Primary Channel Assignment-based MAC (PCAM) protocol, which is based on the use of primary channel assignment with three half-duplex transceivers per node. The PCAM scheme does not require any dedicated control channel or complex synchronization. The primary interface serves as a means for other nodes to contact this node in its primary channel. The secondary transceiver is used mainly for sending data and is not assigned any fixed channel. In addition, a fixed common channel is assigned to the third transceiver to implement broadcast messages. In the proposed scheme, primary channel discovery, instead of channel negotiation is required since primary channels are pre-assigned. For the primary channel discovery, Pathamasunthara, Das, and Gupta propose a route discovery scheme, as in AODV [12], using the broadcast channel.

Adya, et al. [29] propose a MAC protocol called the Multi-radio Unification Protocol (MUP). MUP coordinates the operation of multiple wireless transceivers tuned to non-overlapping frequency channels. The goal of MUP is to optimize local spectrum usage via intelligent channel selection in a multi-hop wireless network. MUP does not

require modifications to standards-compliant IEEE 802.11 hardware or higher-level protocols. However, to utilize multiple channels fully available in a network, MUP requires the same number of the network interfaces in a node. This scheme targets to support stationary wireless network since they assumed that nodes acting as routers are not mobile. Packet re-ordering is needed after NIC switching. MUP relies on TCP (Transport Control Protocol) to handle this issue. However, this will cause low end-to-end throughput in a multi-hop network.

Zhai, et al. [30] propose a MAC protocol to address the inefficiency of the IEEE 802.11 MAC protocol. They identify four problems that cause dramatic performance degradation of the IEEE 802.11 MAC in multi-hop ad hoc networks, namely, the hidden terminal problem, the exposed terminal problem, the receiver blocking problem, and the intra-flow contention problem. Their proposed dual-channel MAC protocol (DUCHA) utilizes dual channels for control packets and data packets. DUCHA includes Negative CTS (NCTS) to solve the receiver blocking problem and an out-of-band receiver based busy tone is used to solve the hidden terminal problem.

Kyasanur, Padhye, and Bahl [31] propose the Control Channel-based MAC Protocol (C2M) utilizing a sliver of unused spectrum in the lower frequency band as a low rate control channel to improve the capacity of infrastructure and multi-hop wireless networks. They consider the scenario where the control and data channels may be in different frequency bands, and the ranges of the two channels are expected to be different. Specifically, the control channel is equipped with the lower frequency band and is expected to have longer transmission range. The longer-range frequency control channel is expected to reduce the effect of hidden terminals on the data channel.

In another study, Deng, Han, and Haas [32] evaluate the maximum achievable throughput of split-channel MAC schemes as a function of the ratio of the bandwidths of the control sub-channel and the entire channel, and compare the results to that of the corresponding single-channel MAC schemes. They conclude that splitting the bandwidth between a control and a data channel may not be beneficial, if the contention resolution duration is randomly distributed. Therefore, the key difficulty with using a split-channel approach is appropriately splitting the available channel bandwidth between the control channel and the data channel. In contrast, the primary motivation for using a control channel in our scheme is to utilize extra frequency bands, which does not require splitting an existing channel into multiple sub-channels.

Yang and Vaidya [33] propose to use pipelining techniques to resolve conflicts between a short contention resolution stage and the possibility of collisions and to improve the performance of multiple access control in terms of channel utilization. They divide the channel into two sub-channels: a control channel and a data channel. The control channel is used for the contention resolution procedure, i.e., random backoff and RTS/CTS handshakes, and data channel is used for DATA/ACK exchanges. While the current packet is transmitting on the data channel, the contention resolution and RTS/CTS handshake for the next packet can proceed on the control channel.

Tantra, Foh, and Lee [34] propose the out-of-band signaling technique to provides better bandwidth usage compared to the in-band signaling techniques. Their effort is to provide better bandwidth usage compared to the in-band signaling technique in the existing scheme with the use of a separate low speed channel for signaling.

Another approach using multiple transceivers is a single MAC with multiple

physical layers. In this scheme, a NIC can include multiple parallel RF front-end chips and baseband processing modules to support several simultaneous channels. On top of the physical layer, there is only one MAC layer to coordinate the functions of the physical multiple channels. However, how to design an efficient MAC protocol for this type of physical layer platform is still an open research topic [35].

### 2.3.2 Network Layer Approaches

Channel assignment and routing are key issues in network layer approaches. Multi-channel schemes at the network layer should provide not only a routing mechanism, but also an efficient channel assignment method. One of the primary advantages of a network layer approach versus a MAC layer approach is to require no modifications to current the IEEE 802.11 MAC protocol.

Alicherry, Bhatia, and Li [38] mathematically formulate the joint channel assignment and routing problem, taking into account interference constraints, the number of channels in the network, and the number of radios available at each mesh router in mesh networks. Their research targets infrastructure mesh networks (IWMNs). In IWMNs, topology change is infrequent and the variability of aggregate traffic demand from each mesh router (client traffic aggregation point) is small. These characteristics allow periodic optimization of the network that may be done by system management software based on traffic demand estimation.

Tang, Xue, and Zhang [39] propose the interference-aware topology control and QoS routing in IEEE 802.11-based multi-channel wireless mesh networks. They present the minimum Interference Survival Topology Control (INSTC) problem to find the chan-

nel assignment for the given network such that the induced network topology has minimum interference among all  $K$ -connected topologies. They also present the Bandwidth-Aware Routing (BAR) problem to find the routes for QoS connection with requested bandwidth requirements.

So and Vaidya [40] propose a routing and channel assignment protocol for multi-channel multi-hop networks that works for nodes equipped with a single NIC. The protocol ensures that every node in the network has at least one route to an AP, while allowing nodes to switch channels to associate with an AP with minimum load.

Kyasanur and Vaidya [41] classify interface assignment strategies and propose a new interface assignment scheme that does not require modifications to IEEE 802.11. Their goal is to ensure that fixed interfaces of nodes in a neighborhood have better spatial reuse. While they propose a simple rule to utilize multiple interfaces and channels, the fixed interface may be overloaded while the switched interface is always idle if a node always receives but does not send. They also identify routing heuristics that are suitable for use with the proposed interface assignment scheme.

Draves, Padhye, and Zill [43] propose a new metric, Expected Transmission Time/Weighted Cumulative (ETT/WCETT), for multi-radio, multi-hop wireless networks that can be used for finding a high-throughput path between a source and a destination. They also present the Multi-Radio Link-Quality Source Routing (MR-LQSR) protocol by incorporating this metric.

Raniwala, Gopalan, and Chiueh [4] propose a multi-channel ad-hoc network architecture for wireless mesh networks. They develop centralized channel assignment, bandwidth allocation, and routing algorithms for multi-channel wireless mesh networks.

The proposed scheme assumes that a virtual link is formed between any two nodes that are within communication range of each other. However, a communication channel is required among nodes to build a virtual link. Additionally, their algorithm is based on heuristics and the worst-case performance bound on its performance is not known [38].

Gong and Midkiff [44] propose a family of distributed channel assignment protocols that combine routing with channel assignment. A cross-layer approach is employed, and an example protocol that utilizes the AODV routing protocol is presented. They show that significantly lower communication, computation, and storage complexity than existing channel assignment schemes can be achieved because of the combination of channel assignment with routing.

### **2.3.3 Channel Assignment Algorithms**

Channel assignment is the one of the key components of a complete multi-channel wireless ad-hoc network architecture [4, 76]. Channel assignment should be distributed due to the ad-hoc nature of the network. Distributed channel assignment problems have been studied for decades, but remain challenging problems [46].

A channel assignment problem also occurs in cellular networks where, because of a limited number of channels, the available channels need to be re-used from cell-to-cell, while maintaining some minimum re-use distance. This leads to the problem of channel allocation where each cell needs to be assigned certain channels based on its traffic and the channels that are used in nearby cells. Various static and dynamic techniques have been proposed and used to solve this problem. The asymmetry of mobile terminals versus base stations and communication between them in a cellular network makes the prob-

lem substantially different from channel assignment in an ad-hoc network. In a cellular network, all mobile devices communicate with their corresponding base station, while base station-to-base station communication is carried over a separate network. [37].

Hu [45] discusses different types of channel assignment schemes and analyzes the throughput of the different assignment schemes. In addition, he explores the relationship between Code-Division Multiple-Access (CDMA) code assignment problems and graph coloring. Pair-wise Code Assignments (PCA) for multi-hop Packet Radio Networks (PRNs), which assigns a CDMA code to each edge node, is proposed. Simulation experiments showed that a PCA system provides comparable throughput using fewer codes than a transmitter-based code assignment scheme.

Kodialam and Nandagopal [48] propose a network model with conditions to verify the feasibility of rate vectors. They also present two link channel assignment schemes, static and dynamic, to derive lower bounds on the achievable throughput.

## 2.4 Summary

In this chapter, we briefly introduced basic concepts related to wireless ad-hoc networks, including the MAC layer protocol defined by the IEEE 802.11 standard, network architectures, and routing protocols. MANET routing protocols, specifically, reactive and proactive routing protocol were discussed, and three proactive protocols, DSDV, OSPF-MCDS, and OLSR, were explained in detail.

In spite of their disadvantages, proactive routing protocols maintain a consistent network view by propagating updates throughout the network. The fact that every mo-

bile node in the network maintains a routing table that records all possible destinations within the network motivates our research.

Compared to previous research, our scheme focuses on using a proactive routing protocol to assign a channel to each node and to deliver channel information in a fully distributed manner. Our protocol does not require tight synchronization among nodes. It assigns channels without using per-packet negotiation, which eliminates the overhead and delay before data transmission required for MAC-based channel negotiation. Our scheme provides a simple way to utilize multiple channels at the cost of dedicating one channel for control messages. Our scheme also allows the use of standard, unmodified IEEE 802.11 NICs. Proposed scheme is illustrated in section 3.3, and the design principles and advantages of our schemes are described in section 4.2 in detail.

In the following chapter, we introduce our approach with a proactive routing protocol for multi-channel wireless networks.

## Chapter 3 Problem Statement and Approach

The IEEE 802.11 MAC protocol is designed to share a single channel in a given network. Since a single channel is used for a network, the MAC protocol is likely to face significant throughput degradation as the number of active nodes and the load increases. This problem cannot be solved at the level of an individual component; rather it must be solved by considering the behavior of the complete system. Thus, the challenge is to design systems that use all available resources (spectrum, energy, hardware, and software) efficiently while being general enough to support a wide variety of applications [49].

Our approach is to utilize extra spectrum using multiple radios on each node, working in an integrated manner to accomplish common tasks. We show that the scheme provides significant benefits in terms of functionality and performance over single-channel systems. Multiple communications at the same time can improve effective network capacity [2, 35]. The challenge, however, is to allow a single ad-hoc network to use the separate channels provided by the PHY layer simultaneously in an efficient

manner to increase effective capacity [2]. This chapter describes the advantages we can expect when multiple channels are exploited and discusses the issues associated with multi-channel schemes. Finally, we present our approach to make use of multiple channels.

## **3.1 Advantages of Using Multiple Channels**

The following advantages are expected by utilizing multiple channels in a wireless ad-hoc network.

### **3.1.1 Increased Capacity**

The network capacity of a single-channel network is limited by the bandwidth of the single channel. Better bandwidth usage can be achieved by enabling more concurrent transmissions. Multi-channel protocols allow multiple nodes in the same neighborhood to transmit concurrently on different channels without interfering with one another. As a result, network capacity can be increased with multi-channel communication.

It is not necessary that all the channels in the system operate in the same general band [49]. Radios that work in different frequency bands may also be used, e.g., a node can have one IEEE 802.11b interface using a 2.4-GHz radio and one IEEE 802.11a interface using a 5-GHz radio. It is important to note that channels in different frequency bands may have significantly different communication ranges and data rates.

Channels can be heterogeneous in that one of the radios might have significantly lower bandwidth with higher range than other radios in the network. Mixtures of different radios may be able to improve the network capacity. The lower bandwidth chan-

nel with higher range on each node can be used as a control channel to coordinate data transmissions on the higher bandwidth radios. Such a system can be significantly more efficient than present systems that use contention-based MAC protocols like IEEE 802.11 [31].

### **3.1.2 Reduced Propagation Delay**

Nasipuri, Zhuang, and Das [50] show that the normalized propagation delay per channel in a multi-channel system is smaller than that in a single-channel environment. The maximum throughput using a single-channel MAC protocol is bounded by the bandwidth of one channel. Thus, using multiple channels should lead to nodes experiencing less normalized propagation delay per channel than in the single-channel counterpart. Further, less normalized propagation delay can reduce the collision probability.

### **3.1.3 Provision of Additional Services**

Multimedia applications such as digital audio and video have much more stringent quality of service (QoS) requirements than traditional applications. For a network to deliver QoS guarantees, it must reserve and control resources. A major challenge in wireless ad-hoc networks is the ability to account for resources so that bandwidth can be reserved. In single-hop networks, such as infrastructure networks, all nodes learn of each other's requirements easily either directly or through an access point. However, this solution cannot be extended to the ad-hoc environment. If we consider "bandwidth" as the QoS metric, it is more convenient to support quality of service when multiple channels are used. This is reasonable because a bandwidth guarantee is one of the most critical requirements for real-time applications. With multi-channel schemes, QoS can be pro-

vided by assigning channels according to a QoS policy considering the current environment, such as the network load on channels.

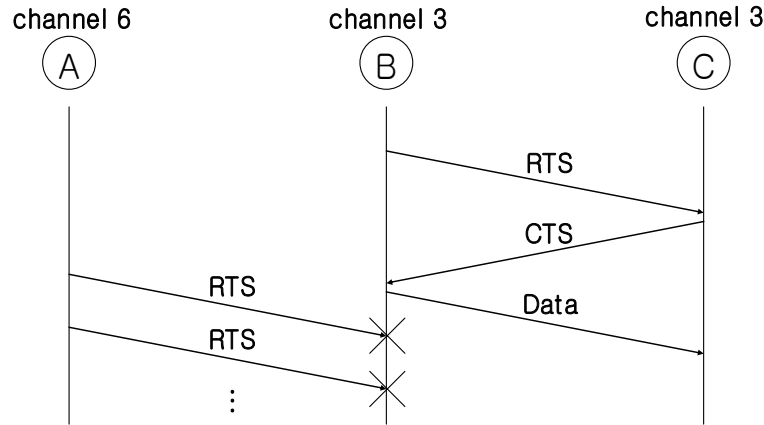
## **3.2 Issues in a Multi-Channel Environment**

In this section, we discuss the general issues related to the scheme for multi-channel networks. In a multi-channel network, different issues not considered in single-channel networks can arise, for instance, channel synchronization and the multi-channel hidden terminal problem.

### **3.2.1 Channel Synchronization**

In multi-channel networks, nodes can be out of channel synchronization if they do not share channel information among neighbors. Ad-hoc network protocols are dependent on the broadcast nature of the wireless medium to operate effectively. In particular, routing protocols for MANETs are dependent on broadcast or multicast messages. Due to the dynamic nature of ad-hoc networks, due to mobility, congestion, and the unpredictable wireless channel, nodes can lose connectivity and have to update their routes frequently.

For instance, consider the scenario of Figure 3.1. Node B is communicating to node C through channel 3 by exchanging RTS and CTS frames. Node A starts communication with node B by transmitting a RTS frame through channel 6. However, since node B listens to channel 3 it cannot hear RTS frames. As a result, RTS frames from node A destined to node B will drop. This problem results from the lack of the channel synchronization among neighboring nodes in a network.

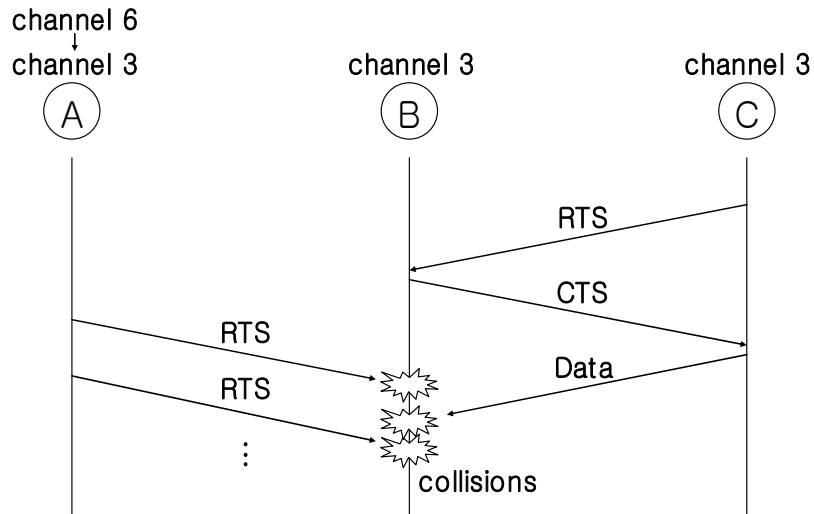


**Figure 3.1:** Channel synchronization problem.

This problem can be solved by using a common control channel [24, 25, 27] or a common period [3, 19, 21, 22] where all neighboring nodes can share channel information among neighboring nodes. In designing a multi-channel scheme, the need for broadcast messages should be considered [28].

### 3.2.2 The Multi-Channel Hidden Terminal Problem

In a single-channel environment, a hidden terminal problem can occur in a situation with at least three nodes, where at least two nodes are out of each other's radio range [2]. In a multi-channel environment, a different hidden terminal problem can occur, as depicted in Figure 3.2. The node misses an RTS/CTS exchange on one channel when listening on another, causing the hidden terminal problem despite use of RTS/CTS signaling. Node B and C are communicating after successful exchange of RTS/CTS. Node A switches to channel 3 from channel 6 since the destination node B is using channel 3. Node A misses the CTS sent out by node B when it switches to channel 3. Node A, a hidden terminal, proceeds to transmit RTS and the frame can collide at node B.



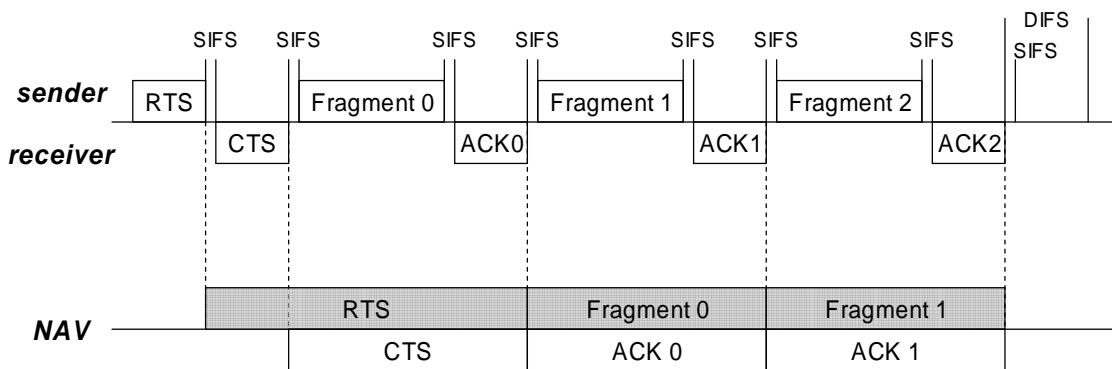
**Figure 3.2:** Hidden terminal problem under multi-channel networks.

This problem can be solved as follows. When a node joins the destination node's channel, it should not send RTS immediately since it could cause a hidden terminal problem. Instead, a node waits for RTS, CTS, or fragment frame to detect any current communication after changing to a new channel. The timeout would be the addition of transmission time of the fragmentation threshold. If the medium is busy, a node must wait for the channel to become idle. Otherwise, a node sends an RTS frame to initiate communication.

A node has to wait for RTS, CTS, or a fragment frame since the NAV is set by these three frames. A node can set the NAV using these three frames so that it knows when the medium is available. All of the fragments that comprise a frame are normally sent in a fragmentation burst. Fragments and their acknowledgments are separated by the Short Interframe Space (SIFS), so a station retains control of the channel during a fragmentation burst. The NAV is also used to ensure that other stations do not use the channel during the fragmentation burst. The RTS and CTS set the NAV from the ex-

pected start-time to the end of the “first” fragments in the air (See Figure 3.3). Subsequent fragments then form a chain. Each fragment sets the NAV to hold the medium until the end of the acknowledgment for the next frame.

In Figure 3.3, Fragment 0 sets the NAV to hold the medium until ACK 1, fragment 1 sets the NAV to hold the medium until ACK 2, and so on. After the last fragment and its acknowledgment have been sent, the NAV is set to 0, indicating that the medium will be released after the fragmentation burst completes. Therefore, if a node joins this channel in the middle of transmission, it should wait for next RTS, CTS, or fragment frame to set the NAV.



**Figure 3.3:** NAV setting for a burst of fragments.

### 3.2.3 Number of Transceivers

We can categorize multi-channel approaches based on the number of transceivers employed and whether nodes require a single transceiver or multiple transceivers. With a single transceiver, a node can access only one channel at a time. However, a single transceiver approach does not necessarily have to be a single channel approach since a transceiver is able to switch from one channel to another. Each node in a multi-channel environment with a single transceiver must perform functions such as negotiating chan-

nel allocations and sharing channel information among neighboring nodes. Prior research with a single transceiver relies on a designated period for control messages to which every node in the network should listen [3, 19, 21, 22].

In contrast, nodes with multiple transceivers are able to access different channels simultaneously. Various schemes can be applied to coordinate multiple channels that can be accessed simultaneously using multiple transceivers. One channel can be dedicated to a control channel and the other channels can be used for data exchange [24, 25, 27, 30, 31, 32, 33, 34] or each channel can be accessed independently [28].

A more involved scheme is to assign transceivers based on the direction of messages. For instance, a particular channel can be assigned for reception and another channel for transmission. The disadvantage of dedicating a channel to each transmission direction is that the channel can be poorly utilized if message flows in the two directions are highly asymmetric, i.e., the data rate in one direction is far below the data rate in the other direction. However, in special cases such as data collection in a sensor network, dedicating a channel to reception of messages can increase network throughput [35, 36].

### **3.2.4 Channel Assignment**

Channel assignment schemes can be categorized as Fixed Channel Allocation (FCA), Dynamic Channel Allocation (DCA), or Hybrid Channel Allocation (HCA) schemes, based on the flexibility of assigning channels to nodes [37]. In FCA schemes, a channel is assigned to each node according to some reuse pattern depending on the desired network size and the number of available channels at the time of network initialization.

The FCA scheme is simple, but it does not adapt to changing traffic conditions and node movement. DCA can overcome these deficiencies of FCA. In the DCA scheme, all channels are placed in a pool and are assigned to a new connection. At the cost of higher complexity, DCA provides flexibility to changing traffic conditions. However, DCA is less efficient than FCA under conditions of high node mobility due to the need to frequently change channel assignments. To overcome this drawback, HCA combines features of both FCA and DCA.

Channel assignment schemes can be implemented in a centralized or distributed fashion [4]. In a centralized scheme, a central controller assigns channels, while in a distributed scheme nodes select channels autonomously. In autonomously organized distributed schemes, each node chooses a channel based on its measurement criteria without the involvement of a central controller. The distributed scheme has lower complexity, but at the cost of lower efficiency. Both FCA and DCA can use a distributed assignment scheme based on local information [37].

Distributed channel assignment schemes can also be categorized as being a Receiver-based Channel Assignment (RCA), Transmitter-based Channel Assignment (TCA), or Negotiation-based Channel Assignment (NCA) scheme. In RCA schemes, the receiving channel of the destination node is assigned to each transmitting node. RCA must find a channel for each node to use to receive packets with the objective that all logical neighbors of a given node have different receiving channels.

In TCA schemes, all neighbors of a given node should have different transmit channels so that no two neighboring nodes can cause a primary conflict. Broadcasting and passive acknowledgements are possible with TCA schemes. However, a receiver

must be able to tune to any of its neighbor's channels. A TCA scheme needs to find a channel for each node to use to transmit packets with the constraint that all logical neighbors of a given node have different transmitting channels, i.e., a transmitter uses its unique channel for transmission and no primary conflict can result from a logical neighbor's transmission.

In NCA schemes, a transmitter-receiver pair negotiates to acquire a channel such that no two adjacent pairs in the logical topology have the same channel. A large number of orthogonal channels are needed in a fully connected network if no interference is required. However, this scheme can result in the utilization of fewer channels than RCA and TCA schemes in a carefully controlled topology [45].

### **3.2.5 Channel Use**

There are two possible ways to make use of multiple channels under the assumption that multiple interfaces are available in a node. These are to use one channel as a dedicated control channel and the others for data and the other is to allow independent access of all channels.

#### **3.2.5.1 Dedicated Control Channel**

Several past research efforts in the use of multiple radio channels that require modification of the MAC layer protocol propose channel separation schemes [24, 25, 27, 30, 31, 32, 33, 34, 77]. In a channel separation scheme, one channel is dedicated as the control channel and the other channels are used for data exchange. Neighboring nodes listen to the common control channel since control messages are exchanged between any transmitter-receiver pair for reservations or other negotiation. This scheme can utilize multi-

ple channels with less control message overhead.

Splitting the bandwidth between a control and a data channel may not be beneficial if the contention resolution duration is randomly distributed [32]. The key issue with a split-channel approach is the appropriate split of the available channel bandwidth between the control channel and the data channel. In addition, it may not perform well in an environment where all channels have the same bandwidth. When the number of channels is small, one channel dedicated for control messages can be costly. In the case of IEEE 802.11b, only three fully orthogonal (non-overlapping) channels are available, so having one control channel results in dedicating 33% of the total available bandwidth to control overhead. However, if the number of channels is large, then the control channel can become a bottleneck and prevent data channels from being fully utilized [22, 24, 25, 27].

### **3.2.5.2 Independent Access**

A more complex control scheme for channel negotiation can allow simultaneous access to different channels by using multiple transceivers. This can increase the channel utilization. Although this scheme seems to be more practical and profitable, practical aspect and feasibility need to be examined in detail [28].

### **3.2.6 Interface and Node Addressing**

If multiple physical transceivers are available, a node can have multiple unique MAC addresses, one for each transceiver. In addition to multiple MAC addresses, a node can have multiple IP addresses since an IP address is tied to an interface and, thus, the MAC address. Several schemes are possible for transceivers regarding address assignment.

For example, each transceiver can be assigned a different MAC address for each interface mapped with a different IP address, alternatively, a single MAC and IP address can be assigned to all interfaces. As a third alternative, multiple unique MAC addresses, one assigned to each interface, can be mapped to a single IP address.

Each scheme is feasible and the best scheme depends on the details of the implementation. In the case of different MAC and IP addresses for each interface, the number of routing message can increase. Since each interface has a different IP address, each interface works as an independent node. Thus, nodes may exchange routing messages frequently in proportion to the number of interfaces rather than the number of nodes.

As far as the MAC layer is concerned, a single MAC address for multiple interfaces does not cause a problem as long as each transceiver stays on a different channel. Especially, if a single channel is dedicated as the control channel, one interface should stay on the control channel and listen to control information. A single IP address can be assigned to each node regardless of the number of physical transceivers as well. A node can acquire a neighboring node's single MAC and IP addresses.

### **3.2.7 Busy Receiver**

The channel availability of the receiver should be considered when multiple channels are used. For instance, in a design where the transmitter is tuned to the receiver (RCA), the transmitter is notified of the channel availability of the receiver while the channel switching occurs. Otherwise, the transmitter-receiver pairs can lose synchronization and will not be able to communicate [28].

### 3.3 Proposed Approach to Multi-Channel Ad-hoc Networking

The routing protocol is one of the fundamental functions in a MANET [9]. Several standard routing protocols for MANETs have been defined [5, 7, 11, 12, 13, 15], but there is not yet widespread acceptance of one or a few protocols. In addition, all of these protocols are designed for single-channel operation. Furthermore, routing protocols for multi-channel networks have not been studied thoroughly. Before our research, most past research in the use of multiple radio channels required the modification of the MAC layer protocol. Compared to previous research, our scheme focuses on using the routing protocol, especially proactive protocols, to assign a channel to each node and to deliver channel information. This protocol does not require close synchronization among nodes, which reduces complexity. It also does not require channel negotiation, which eliminates the associated overhead and the delay that is introduced before data transmission.

Only proactive routing protocols are capable of providing each node with full topology information for the network. Nodes can use this topology information for the initial channel assignments and for channel switching for data transmission. A complete multi-channel wireless ad-hoc network architecture requires topology discovery, traffic profiling, channel assignment, and routing [4]. However, proactive routing protocols can be inefficient because of the need for periodic updates, regardless of the number of network topology changes and network traffic. To overcome this limitation, the network layer is divided into a control plane and a data plane in our proposed scheme. Routing packets use the control plane and user packets (packets from an upper layer) use the data plane. Nodes transmit broadcast and multicast packets using the common control chan-

nel.

To demonstrate the proposed multi-channel routing scheme, we extend the DSDV, OSPF-MCDS, and OLSR MANET routing protocols to multi-channel versions, DSDV-MC, OSPF-MCDS-MC, and OLSR-MC, respectively. (See Sections 4.3, 4.4, and 4.5 for additional information.) DSDV is a simple and fast routing protocol and we focus on having the multi-channel scheme maintain the benefits of the proactive DSDV routing protocol. OSPF-MCDS, in comparison to DSDV, provides good performance for large and dense mobile networks with heavy traffic in terms of the number of traffic flows because of the idea of broadcast using a minimal connected dominating set. The larger and more dense a network, the greater the performance improvement as compared to DSDV which employs blind broadcasts [6]. OLSR inherits the stability of a link state algorithm and has the advantage of having routes immediately available when needed due to its proactive nature. OLSR is an optimization over the classical link state protocols that is tailored for mobile ad hoc networks. OLSR, like OSPF-MCDS, minimizes the overhead from flooding of control traffic by using only MPRs to retransmit control messages. The protocol is particularly suited for large and dense networks, as the optimization done using MPRs works well in this context. The larger and more dense a network, the more optimization can be achieved as compared to a classic link state algorithm [7].

In our proposed scheme, we assume that two or more transceivers are available. One of the available channels (the control plane) is dedicated to control messages and the remaining one or more channels (the data plane) are used for data transfers. The channel synchronization problem can be eliminated since nodes share control information through the control channel. We consider each node being equipped with two transceiv-

ers so that it can listen on the control and data channel concurrently. Routing messages with channel information are exchanged through the control channel to address the hidden terminal problem. As discussed in Section 3.2.5, even though independent access seems to be practical and beneficial, this is beyond our current scope and remains a topic for future research.

Channels are assigned dynamically, using a dynamic channel allocation (DCA) scheme, in a distributed fashion according to the channel distribution from the available channel pool. A transmitting node switches a data channel to a receiving node (RCA scheme) based on the channel information. For addressing, we assume that each node has a same MAC address for each interface with a single IP address for the node so that neighboring nodes can acquire a single IP address for the node through the Address Resolution Protocol (ARP) for IPv4 or Neighbor Solicitation (NS) for IPv6.

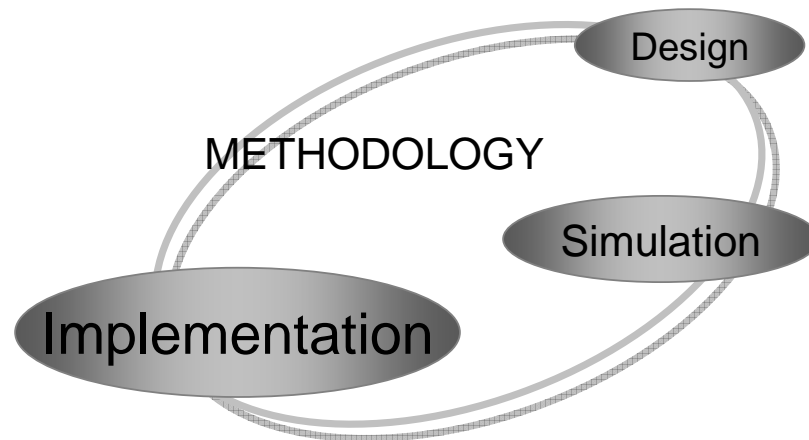
With a proactive routing protocol for a multi-channel network, we introduce a new metric, the Channel Distribution Index (CDI), as discussed further in Chapter 5. Utilization of multiple channels in ad-hoc networks provides the benefits of increasing network capacity and increasing efficiency by reducing the probability of collisions. Multi-channel schemes are becoming more attractive as the cost of transceivers decreases and the capacity requirements for potential ad-hoc network applications increase. However, channel assignment mechanisms may distribute channels unfairly to different nodes, thus leading to inefficient use of available capacity and creating system bottlenecks. CDI measures the fairness of channel distribution and indicates the dynamic channel distribution among neighboring nodes (see Section 5.2). Our proposed metric for multi-channel wireless ad-hoc networks can be used to evaluate the fairness of the channel assignment

and MAC schemes and, in the future, to improve their efficiency. The basic approach is to let nodes measure the fairness of channel distribution among their neighbors so that available multiple channels can be efficiently and fairly utilized.

Along with CDI, we introduce a channel reallocation scheme to mitigate the impact of the channel convergence problem, which is discussed in more detail in Section 5.3. Nodes are able to utilize the standardized criterion to determine the unfairness of channel distribution. Each node keeps the reference index as the standardized threshold. Our current implementation provides manual configuration for the reference index. However, the reference index should be adaptive to changes since the distribution of CDI can be altered due to the dynamic nature of large multiple-hop ad-hoc networks. The adaptive reference index scheme is discussed in Section 8.3.2 as possible future work.

### **3.4 Methodology**

The methodology for our approach can be broken down to three major phases: design, simulation, and implementation. Figure 3.4 depicts the methodology. Careful design and analysis can lead to accurate simulation model and implementation, and we are able to verify the proposed scheme through the simulation and implementation. A proactive routing scheme for a multiple channel network is presented in this dissertation.



**Figure 3.4:** Methodology.

A new node model is implemented in ns2 (Network Simulator 2) to evaluate the proposed scheme through simulation experiments. Simulation is essential in the case where the model is very complex with many variables and interacting components. Another important aspect of the simulation technique is that we build a simulation model to replicate the actual system [42]. Ns2 is a discrete event simulator targeted at networking research. It provides substantial support for simulation of protocols such as TCP, routing, and multicast over various networks, for instance, wireless, wired, and satellite. It describes systems that are assumed to change instantaneously in response to certain discrete occurrences. In this research, two example proactive routing protocols are extended to verify the proactive routing protocol for multiple channels in ns2.

With verified simulation results in hand, we present the implementation to verify that the proposed scheme successfully exploits multiple channels to improve network capacity and increases the network throughput. A proactive routing protocol is implemented on Linux with multiple physical network interfaces. Specifically, we adapt the

Naval Research Laboratory (NRL) OLSR implementation, `nrlolsrd`, which consists of NRL-developed code [47]. We made modifications to the Linux version of `nrlolsrd` for OLSR-MC. We present the virtual interface (VI) to realize the multi-channel scheme in Linux to avoid complex changes to the kernel's network subsystem. Section 7.2 covers the virtual interface module (VIM) in detail.

### **3.5 Summary**

In this chapter, we described the advantages when we make use of multiple channels, such as increased throughput, reduced propagation delay, and the provision of additional services using multiple channels. We, also, discussed the general issues that arise when using multiple channels, such as the hidden terminal problem, the number of transceivers, channel assignment, channel utilization, and addressing. An approach to multi-channel ad-hoc networking was proposed. Chapter 4 describes the use of proactive routing protocols for multi-channel networks in detail.

## **Chapter 4 Proactive Routing Protocols for Multiple Channels**

Only proactive routing protocols are capable of providing each node with full topology information for the network. Nodes can use this topology information for the initial channel assignments and for channel switching for data transmission. However, proactive routing protocols can be inefficient because of the need for periodic updates, regardless of the number of network topology changes and network traffic load. To overcome this limitation, the network layer is divided into a control plane and a data plane in our proposed scheme. Routing packets use the control plane and user packets (packets from an upper layer) use the data plane. Channel information is piggybacked in routing messages. Broadcast and multicast packets are transmitted using the common control channel. This chapter describes the design principles of the proposed multi-channel routing protocol and presents extensions to existing proactive routing protocols to use our multi-channel scheme. We also discuss issues that can arise when we use the proposed proactive routing protocol for a multi-channel network.

## 4.1 Assumptions

We assume that  $N$  data channels are available to use and that all  $N$  channels have the same bandwidth. No channels overlap, so packets transmitted on different channels do not interfere with each other. Nodes have prior knowledge about how many channels are available. Second, each node is equipped with two half-duplex transceivers. A single transceiver can either transmit or listen at a given time, but cannot do both simultaneously. Different transceivers at a host can listen to or transmit on different channels simultaneously. Third, we assume that the channel switching overhead is negligible since rapid channel switching will become feasible with the availability of improved hardware [26, 43]. Finally, we assume that no network is present other than the multi-channel network so that nodes are able to use the common control channel and data channels without interference from other networks.

## 4.2 Design Principles

Our proposed multi-channel scheme can be combined with any typical proactive routing protocol. Proactive protocols have many desirable properties, especially for applications including real-time communications and QoS guarantees, such as low-latency route access and alternate QoS path support and monitoring. Most of all, proactive routing protocols are capable of providing each node with full topology information for the network, and we use this topology information for the initial channel assignment and channel switching for data transmission.

However, proactive routing protocols can be inefficient because of the need for periodic updates, regardless of the number of network topology changes and network traffic. To overcome this limitation, the network layer is divided into control and data planes in our proposed scheme. Routing packets use the control plane and user packets (packets from an upper layer) use the data plane. Broadcast and multicast packets are transmitted using the common control channel. We do not consider the use of reactive, or on-demand, MANET routing protocols.

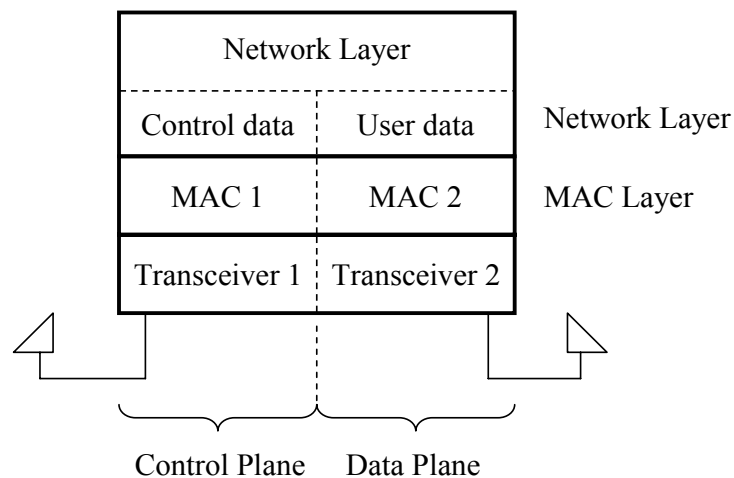
As stated in Section 4.1, each node is equipped with two transceivers so that it can listen on the control and data channel concurrently. The proposed routing protocol should be compatible with current IEEE 802.11 ad-hoc network mode of operation without modification to the MAC protocol. No network is present other than the multi-channel network, so nodes are able to use common control channel and data channel without interference from other networks.

We divide the network layer into control and data planes. Control packets are essential messages to be shared among nodes in a network such as broadcast and multicast messages. From the perspective of the network layer, routing messages belong to the control plane and user messages are in the data plane. Control plane packets are transmitted via the common control channel so that control frames can be shared among neighboring nodes. If control plane packets are not shared among neighboring nodes, nodes can be out of channel synchronization as discussed in Section 3.2.1. User data (data plane) packets are transmitted via the data channel selected according to the channel information in the routing table. As shown in Figure 4.1, control and data planes have separate protocol stacks underneath the network layer. Therefore, the MAC proto-

col for each plane works separately, which requires no modifications to the current MAC protocol.

Using a single MAC address for both transceivers does not cause any problems since the two transceivers always stay in different channels – one in the common control channel and the other in one of the data channels. With respect to IP addressing, using different MAC addresses, also, does not cause problems as long as the MAC address is resolved to the correct IP address. A single IP address is assigned to each node, thus a unique MAC and IP address pair can be obtained for a destination node.

All incoming and outgoing packets diverge and converge at the network layer. For example, routing messages from the network layer should be transmitted through the control channel at the MAC layer, and user data packets should be transmitted using the data channel at the MAC layer. Likewise, incoming frames from the MAC layer, regardless of whether they are from the control plane or the data channel, are delivered and processed transparently in the network layer. Figure 4.1 illustrates this situation.



**Figure 4.1:** Control and data planes at a node with two transceivers.

### 4.2.1 Channel Allocation

The principle for channel allocation is to combine channel assignment with a routing mechanism. Piggybacking channel information in routing messages is motivated by the fact that each node using a proactive routing algorithm maintains a consistent view of the network. In addition, transmitting channel information through routing control messages can greatly reduce the communication complexity of channel assignment protocols. For instance, a recently proposed channel assignment algorithm has a communication complexity of  $O(d^2)$ , where  $d$  is the maximum number of one-hop neighbors any node can have (maximum network degree) [46]. By carrying channel information through routing messages, the complexity of computation at nodes can be reduced to  $O(1)$ .

When allocating channels initially, nodes consider channel information of nodes that are up to two hops away to mitigate interference. Channel information for nodes that are one hop away, i.e., direct neighbors, has higher priority than that for nodes two hops away in allocating channels. Nodes select the least assigned channel among one-hop neighboring nodes. If there are multiple least used channels from the one-hop neighbors, then the least assigned channel among the two-hop neighboring nodes is selected. In the case of multiple least used channels among two-hop neighbors, the channel assigned is chosen randomly from among the least used channels.

```

Variables
 $m_1$ : number of 1-hop away neighbor nodes
 $m_2$ : number of 2-hop away neighbor nodes
Channel Allocation()
  get  $m_1$  from routing table
  if (the least used channels among  $m_1 > 1$ ) {           (1)
    get  $m_2$  from routing table
    if (the least used channels among  $m_2$  out of (1)  $> 1$ ) {   (2)
      choose randomly from (2)
    } else {
      return the least used channel
    }
  } else {
    return the least used channel
  }
}

```

**Figure 4.2:** Pseudocode for the channel assignment procedure.

### 4.2.2 Delayed Initial HELLO Message

When a node joins a multi-channel network, it needs to decide the initial data channel. In our scheme, this initial channel is selected based on the channels used by neighboring nodes (the least used channel is selected). Since data channel information is piggy-backed with HELLO messages, a newly joined node will defer sending a HELLO message to receive HELLO messages from neighbors to create the channel information table for neighboring nodes and, then, select its initial data channel according to the channel information table using the procedure explained in Section 4.2.1. This delay should not impede routing functions, which has been verified with experiments using simulation and

implementation.

When deciding routes, channel information from one-hop neighbors is sufficient since a transmitting node only needs to know the next-hop node's data channel to forward packets. However, when selecting an initial channel, a node needs the channel information for up to two-hop neighbors since interference from two-hop neighbors should be considered.

### **4.2.3 Channel Switch and Update for Communication**

The channel switch procedure for communication between nodes operates as follows. In an RCA scheme, the data channel of the transmitting node is determined according to the receiving node's data channel. Therefore, a node intending to transmit packets should switch its data channel to the destination node's data channel or the next hop's data channel if the destination is more than one hop away. A transmitting node looks in its channel information table to determine the channel to use when it has a packet to transmit. Based on the destination node, the node determines the next hop and its data channel from the routing table and the channel information table.

When a node changes its data channel to communicate, it broadcasts its channel switch so that neighboring nodes can update their channel information tables accordingly. If a node switches its data channel without sending a notification to its neighbors, then the neighboring nodes can have stale channel information in their channel information tables. This problem is called the "busy receiver problem" in a multi-channel network. To avoid this problem, a node intending to change channels broadcasts its routing information with the new channel index before it switches channels. The Channel Update

(CU) packet is the new message intended to avoid the busy receiver problem in our proposed scheme for a multi-channel network.

#### **4.2.4 Advantages of the Proposed Scheme**

The following advantages can be expected by using the proposed multi-channel routing protocol in a wireless ad-hoc network.

##### **4.2.4.1 No Channel Negotiation**

Channel negotiation for a data channel when packets are available to transmit can lead to significant channel negotiation overhead in terms of both latency and network traffic. When a sufficiently large number of nodes have data to transmit, channel negotiation over the control channel would be a bottleneck and prevent data channels from being fully utilized [24, 25, 27]. In the proposed scheme, channel information is piggybacked in routing protocol packets. Therefore, channel information is available to neighbor nodes along with the network topology information. Nodes are able to select the data channel of the destination node (or the next hop if the destination is multiple hops away) according to the channel information in the channel information table without any channel negotiation. Consequently, we can reduce latency and congestion in the control channel.

##### **4.2.4.2 No Channel Scanning**

In some multi-channel schemes, transmitting nodes are required to do full channel scanning to select the best channel [25, 51]. To find the best channel, a node must scan all channels and select the channel with the lowest sensed power when it has a packet to

transmit. This scheme provides a way to find the best channel at the sender, which reduces collisions at the receiver. However, the overhead of channel scanning can be high when network loads are heavy and the number of available channels is large. The proposed scheme does not need channel scanning since nodes keep the channel information in the routing table, which is updated with routing information as necessary. This can save time and resources.

#### 4.2.4.3 No Clock Synchronization

Each node in an ad-hoc IEEE 802.11 network periodically sends out beacons to synchronize time in a distributed manner. When transmitting a beacon, a node includes a timestamp based on its local timer. If a node receives a beacon from another node, it cancels its beacon and adjusts its timer according to the timestamp in the received beacon [1]. This is a relatively straightforward operation for a single-hop network. However, in a multi-hop ad-hoc network, clock synchronization is a difficult task because of unpredictable communication delays and node mobility, especially when the network is large [52]. Past research proposed multi-channel schemes that need this type of tight clock synchronization among nodes [3, 19, 21, 22]. Our proposed routing protocol does not require such tight clock synchronization among nodes since it uses the synchronization mechanism defined in the standard.

#### 4.2.5 Complexity Analysis

Proactive routing protocols require nodes to maintain routing tables containing entries for all the nodes in the network, which implies storage complexity of  $O(N)$ , where  $N$  is the number of mobile nodes in the network. Storage complexity measures the order of

the table size used by the protocols. Communication complexity gives the number of messages needed to perform an operation when an update occurs, which is  $O(N)$  for the proposed scheme.

One of the proposed channel assignment algorithms has a communication complexity of  $O(d^2)$ , where  $d$  is the maximum number of one-hop neighbors any node can have [46]. With our scheme, transmitting channel information through routing control messages can greatly reduce the communication complexity of channel assignment protocols, so that the complexity of computation at nodes can be reduced to  $O(1)$ .

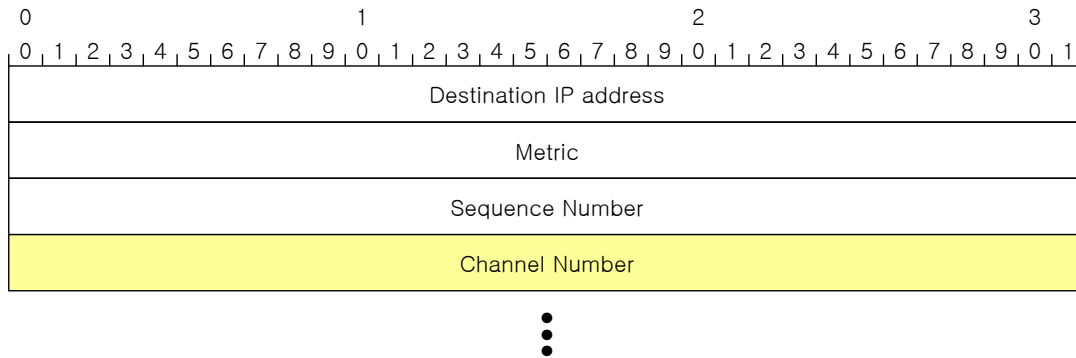
### 4.3 DSDV-MC: DSDV for Multiple Channels

To demonstrate the proposed multi-channel routing scheme, we extend the DSDV routing protocol into a multi-channel version, DSDV-MC. The routing table at each node lists all available destinations, the number of hops to each destination, and the channel index of each neighboring node. To maintain the consistency of routing tables in a dynamically varying topology, each node periodically transmits updates. Nodes also transmit updates immediately when significant new information is available, such as a topology change or a channel switch.

Nodes advertise routing information periodically using the common control channel and, also, incrementally as topology changes are detected or a channel switch is necessary. The incremental messages do not affect DSDV's loop-free property. While nodes delay the advertisement of routes that may not yet be stable to reduce the number of rebroadcasts, nodes immediately transmit a channel change advertisement.

### 4.3.1 Channel Assignment and New HELLO Message

The DSDV-MC protocol requires each node to advertise its routing table to all of its current neighbors. A data broadcast by each node contains its new sequence number for the broadcast and the following information for each new route: the destination address, the number of hops to the destination, the sequence number for this destination, and the associated channel index for the transmission. Figure 4.3 shows the new packet format of a HELLO message with channel information.



**Figure 4.3:** DSDV-MC HELLO message.

When a node joins a network, it receives routing messages from neighboring nodes containing channel information. Each node in the network selects a channel based on the procedure illustrated in Section 4.2.1.

### 4.3.2 Channel Switch

In an RCA scheme, the data channel of the transmitting node is determined according to the receiving node's data channel. Therefore, a node intending to transmit packets should switch its data channel to the destination node's data channel or the next hop's

data channel if the destination is more than one hop away. A node looks in the routing table to select a channel when it has a packet to transmit. Based on the destination node, the node determines the next hop and its data channel from the routing table.

If a node switches its data channel without sending a notification to its neighbors, then the neighboring nodes can have stale channel information in their routing tables. To avoid this problem, a node intending to change channels broadcasts its routing information with the new channel index before it switches channels. As for regular DSDV, two types of routing information messages are defined: (1) “full dump” messages that carry all the available routing information; and (2) “incremental” messages that carry only information that has changed since the last full dump. A channel switch event triggers the broadcast of an incremental message that carries only information changed by the channel switch.

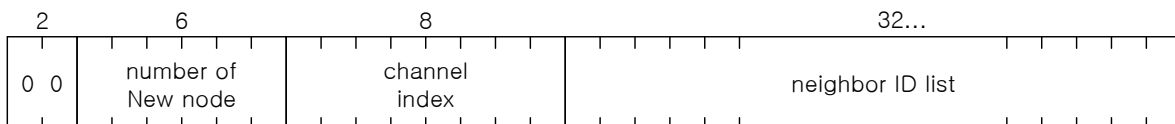
#### **4.4 OSPF-MCDS-MC: OSPF-MCDS for Multiple Channels**

We demonstrate the proposed multi-channel routing scheme with OSPF-MCDS-MC, the multi-channel version of OSPF-MCDS [53]. As a general proactive routing protocol, the routing table at each node in OSPF-MCDS-MC lists all available destinations, the number of hops to each destination, and the channel index of each neighboring node. Nodes periodically broadcast HELLO messages to detect new neighbors and a time-out scheme is used to find expired neighbors. OSPF-MCDS reports the link state changes immediately after the link changes are detected. This implies that OSPF-MCDS requires relatively higher control overhead than DSDV.

### 4.4.1 New Hello Message

Nodes in the OSPF-MCDS-MC protocol periodically broadcast HELLO messages to detect new neighbors. If a new HELLO message is received (after the corresponding link is stable), the sender’s IP address will be added to the receiver’s next HELLO message as the router ID for that new neighbor. If a node receives a HELLO message containing its ID (its own IP address), a two-way connection is determined to be established. When the sender has the smaller node ID, the receiver sends a Link UP Link State Description message if there is no Link Database Description message to be sent soon. Otherwise, the new neighbor’s IP address will be included in the next HELLO message. A new HELLO message includes the list of newly detected neighbors and channel information. Figure 4.4 shows the general packet format of the extended HELLO message containing the channel index.

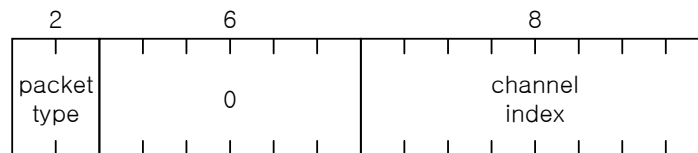
When a node joins a network, it receives HELLO messages from neighboring nodes containing channel information. Each node in the network selects a unique channel as discussed in Section 4.2.1. If an expected HELLO message is missing in a period of Dead Interval time, the generator of that HELLO message is considered to be lost. In other words, the link is considered to be down. In that case, the other node and its associated channel information are deleted from the routing table.



**Figure 4.4:** New OSPF-MCDS-MC HELLO message.

### 4.4.2 Channel Update (CU) Message

As discussed in Section 4.2.1, a node intending to transmit packets should switch its data channel to the destination node's data channel or the next hop's data channel if the destination is more than one hop away. A node looks in the routing table to select a channel when it has a packet to transmit. Based on the destination node, the node determines the next hop and its data channel from the routing table. If a route to a destination node is not available, packets to that destination are queued. A node intending to change its receive channel broadcasts its channel information before it switches. Figure 4.5 shows the format of the channel update packet in OSPF-MCDS-MC.



**Figure 4.5:** OSPF-MCDS-MC CU message.

## 4.5 OLSR-MC: OLSR for Multiple Channels

OLSR-MC is the multi-channel version of OLSR to demonstrate the proposed multi-channel routing scheme [54]. Nodes periodically broadcast HELLO messages with channel information to detect new neighbors and channel usage. The new message, the Channel Update packet, is broadcast before the channel change occurs, which is intended to avoid the busy receiver problem in a multi-channel network. Since channel information is piggybacked with HELLO messages, a newly joined node defers sending a HELLO message to receive HELLO messages from neighbors and select its initial data

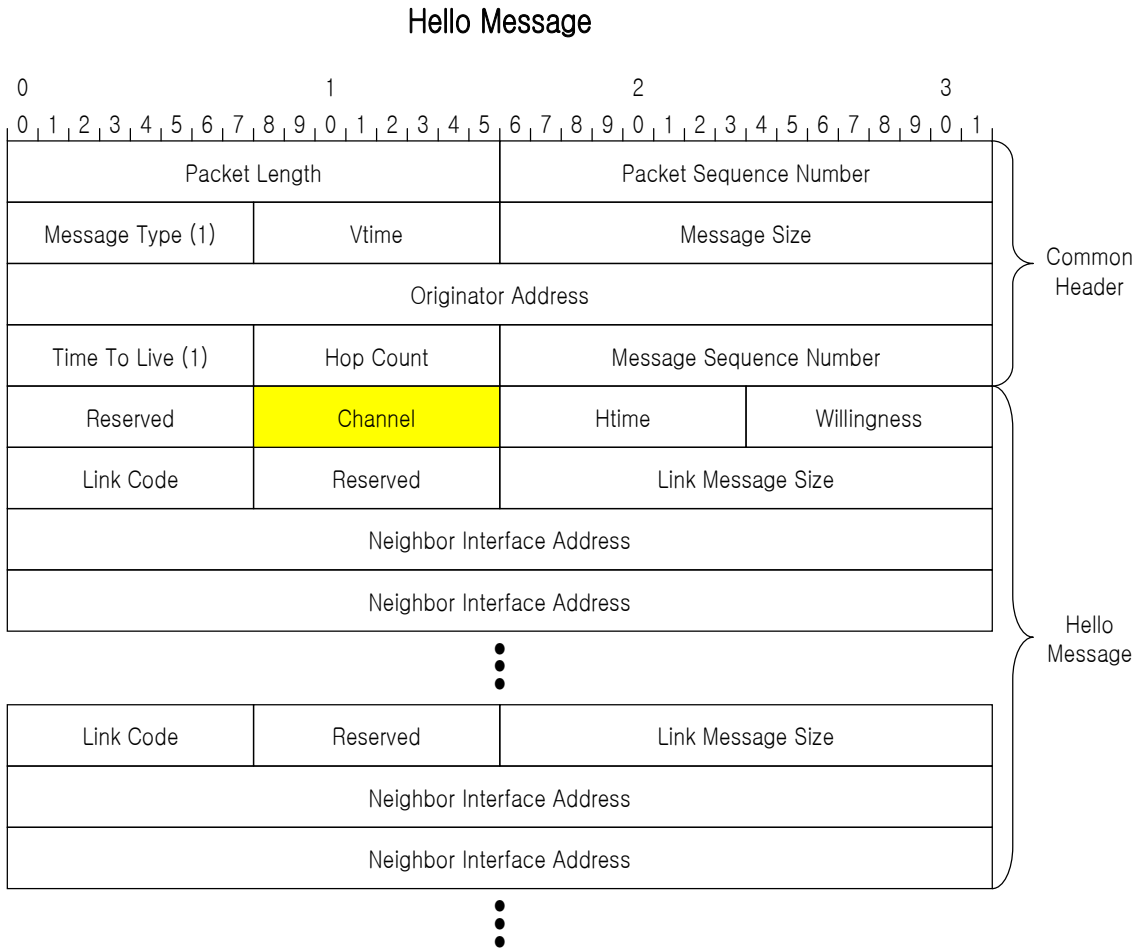
channel. The following sections describe the modification to the OLSR for multi-channel version.

### **4.5.1 New HELLO Message**

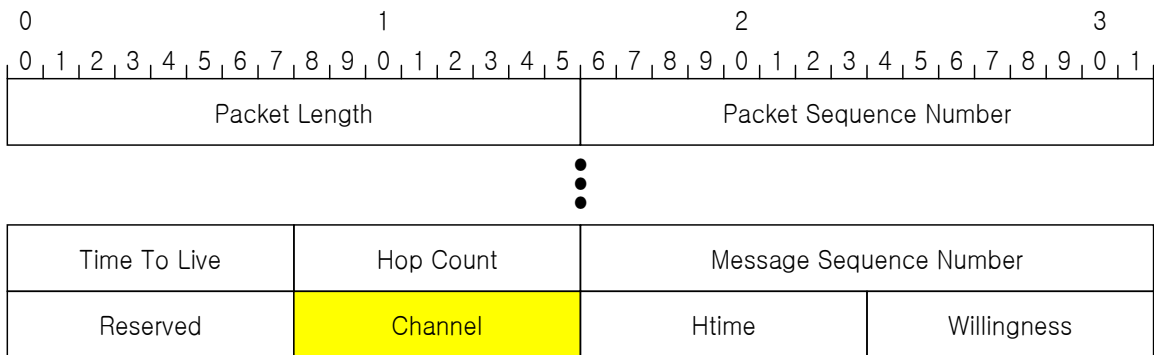
A new HELLO message contains the channel index of each node. Neighboring nodes update their neighbor (NBR) table based on this information. Given the link state information acquired through periodic message exchanges, as well as the interface configuration of the nodes, the routing table for each node can be computed. The physical interface information in the routing table is replaced with the VIM interface so that user data packets are forwarded to the VIM interface.

### **4.5.2 Channel Update (CU) message**

The Channel Update (CU) packet type is the new message intended to avoid the busy receiver problem in a multi-channel network as discussed in Section 4.2.1. If a node switches its data channel without any notification to its neighbors, the neighboring nodes can have stale channel information in their routing tables. A node intending to change its channel broadcasts its new channel index before it switches to the new channel. The extended message is shown in Figure 4.7.



**Figure 4.6:** OLSR-MC HELLO message.



**Figure 4.7:** OLSR-MC CU message.

## 4.6 Proactive Routing Protocol Issues for Multiple Channel Networks

In this section, we discuss issues that can arise when we use the proposed proactive routing protocol for a multi-channel network.

### 4.6.1 Efficiency

As we discussed in Section 3.2.5, splitting the bandwidth between a control and a data channel may not be beneficial, if the contention resolution duration is randomly distributed [32]. In an environment where all channels have the same bandwidth, the channel separation scheme can be inefficient. Especially, if data channels are assigned to each node even though data is not available to transmit, the available channels can be used inefficiently.

If data channels are allocated to active nodes on demand, available channels can be utilized more efficiently. However, this is an inevitable disadvantage for proactive routing protocols since, unlike the on-demand behavior of reactive routing protocols, proactive routing protocols are table-driven and regularly exchange topology information with other nodes in the network.

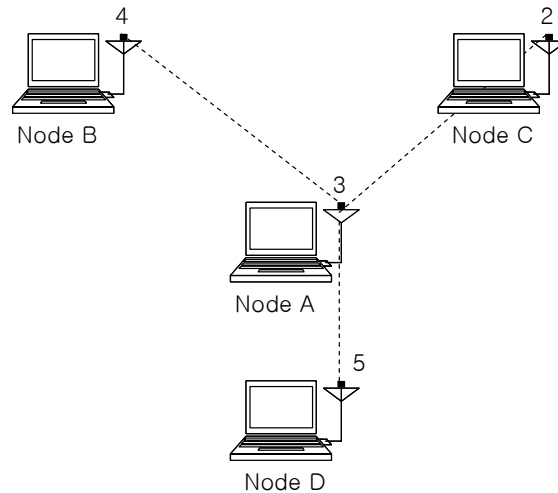
In addition, when the number of channels is small, one channel dedicated for control messages can be costly. In addition, if the number of channels is large, the control channel can become a bottleneck and prevent data channels from being fully utilized [22]. However, unlike MAC schemes proposed by Jain, Das, and Nasipuri [25] and Wu, *et al.* [27], the control channel in proposed scheme does not become a bottleneck and, thus,

does not prevent data channels from being fully utilized even though the number of channels is large since there is no channel negotiation procedure through the control channel in proposed scheme.

#### **4.6.2 Channel Convergence Problem**

In an RCA scheme, the data channel of the transmitting node is determined according to the receiving node's data channel. Therefore, a node intending to transmit packets should switch its data channel to the destination node's data channel or the next hop's data channel if the destination is more than one hop away. Due to the channel assignment scheme of RCA, a single channel or a fewer number of channels than available can be used regardless of the number of available channels. As a result, we are not able to fully utilize all available multiple channels. We call this the "channel convergence problem."

For instance, suppose that node A is the server, such as a data collector, and listening on channel 3, as shown in Figure 4.8. Neighboring nodes, nodes B, C, and D have data to transmit to node A. As nodes B, C, and D initiate data transmission, they switch their data channel according to channel on which node A is listening. As a result, only channel 3 will be used by nodes A, B, and C out of the available channels. This channel convergence problem can be resolved using the channel reallocation scheme and the CDI. The channel distribution and reallocation scheme are covered in detail in Chapter 5.



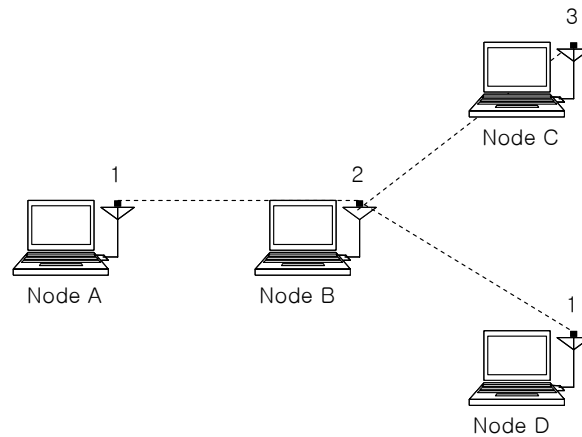
**Figure 4.8:** Illustration of the channel convergence problem.

### 4.6.3 Frequent Channel Switching

Another issue that can arise with an RCA scheme for channel assignment scheme is the “frequent channel switching” problem. This problem can occur in a situation where a node needs to switch its data channel frequently if a node has messages destined to multiple destinations with different channels. The channel change occurs in proportion to the number of multiple destinations with different channels increases and data to transmit. For instance, node A has messages destined to nodes C and D listening on channel 3 and channel 1, respectively, as shown in Figure 4.9. To relay messages from node A to node C and D, node B needs to keep switching its data channel to channel 1 and then to channel 3.

This problem can also occur with channel negotiation schemes in the MAC layer. If the “best” channel negotiated by node B and C is different from the “best” channel from node B and D (which is likely), node B needs to keep switching its data channel back and forth between to the channels selected by the node pair B-C and the node pair

B-D.



**Figure 4.9:** Illustration of the frequent channel switching problem.

#### 4.6.4 Power Saving

With increasing interest in energy constrained multi-hop wireless networks, a fundamental problem is to lengthen the lifetime of batteries to increase a network lifetime. As with any other network interface, powering down the transceiver can lead to great power savings in wireless networks. When the transceiver is off, it is said to be sleeping, dozing, or in power-saving (PS) mode. When the transceiver is on, it is said to be awake, active, or simply on. Power conservation in IEEE 802.11 is achieved by minimizing the time spent in the latter stage and maximizing the time in the former [1].

Power management can achieve the greatest savings in infrastructure networks. All traffic for mobile stations must go through access points, so they are an ideal location to buffer traffic. There is no need to implement a distributed buffer system on every station; the bulk of the work is left to the access point. By definition, access points are aware of the location of mobile stations, and a mobile station can communicate its power

management state to its access point. Furthermore, access points must remain active at all times. It is assumed that they have access to continuous power. Combining these two facts allows access points to play a key role in power management on infrastructure networks [1].

However, power management in an IBSS is not as efficient as power management in an infrastructure network. In an IBSS, far more of the burden is placed on the sender to ensure that the receiver is active. Receivers must also be more available and cannot sleep for the same lengths of time as in infrastructure networks.

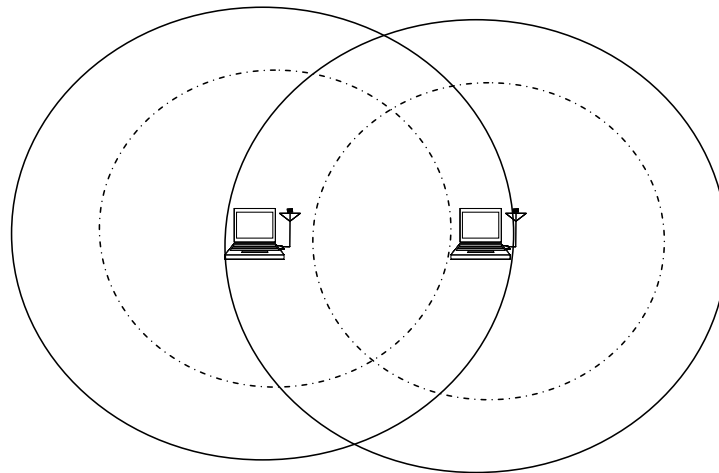
In the proposed multi-channel scheme, the control and data interface can perform power management independently. The control interface may need to stay active to transmit and receive HELLO packets in a periodic manner. However, the data interface can sleep as defined in the power saving mechanism in IEEE 802.11 [1]. The two interfaces are orthogonal, and the routing mechanism would not be influenced by separate power saving operations. There has been a lot of research emphasis on energy efficient protocols for mobile ad hoc networks (MANETs) [52, 55, 56, 57, 58]. Power saving issues in the proposed scheme is beyond the scope of our current research.

#### **4.6.5 Asymmetric Links**

An environment with asymmetric links, for example with different uplink and downlink capacities provides challenges for channel assignment and channel reallocation. Adaptive policy and capacity estimation techniques should be considered due to the asymmetric link capacity. For instance, if the one of data channels has higher bandwidth than the other data channels, more nodes should be assigned to this channel so that the higher

bandwidth should be shared efficiently. This network environment requires a sophisticated channel assignment scheme.

Asymmetric range of links for the control and data channel can also introduce a different issue. The routing information to the destination node (or the next-hop node if the destination is more than one hop away) is determined by the routing message through the control channel in the proposed scheme. Therefore, regardless of the effective ranges of the data channels, a node determines that it is able to reach a destination node according to information in the routing table. This can cause a problem if the range of one of the data channel is less than the range of the control channel, as illustrated in Figure 4.10. However, as discussed in Section 3.1.1, efficient combination of different channels with different range and bandwidth can significantly increase the network capacity [31, 49]. This issue requires more research and is left for future work.



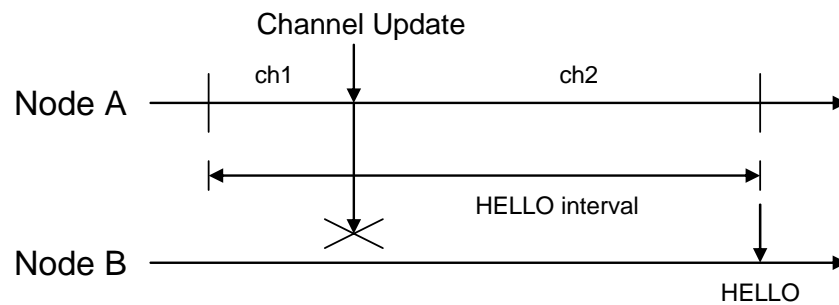
**Figure 4.10:** Asymmetric ranges for the control and data channel.

#### 4.6.6 Channel Errors

Since the wireless medium is error-prone, control messages such as HELLO or CU can

be lost. Although retransmission for the control messages is not provided, loss of control packets does not lead to the loss of channel synchronization since channel information is available in the subsequent HELLO message.

For example, node A in Figure 4.11 switches its data channel from channel 1 to channel 2 and broadcasts CU message. If a CU message is assumed not to be delivered due to a channel error, node B can have stale channel information for node A for a period of time between the loss and the next HELLO message (loss of channel synchronization). However, the following HELLO message from node A includes channel information for node A, which will synchronize channel information in node B with node A.



**Figure 4.11:** Illustration of CU message loss.

## 4.7 Summary

In this chapter, we introduced the design principles for our proposed scheme and extended routing protocols to support multi-channel operation, which we call DSDV-MC, OSPF-MCDS-MC, and OLSR-MC to demonstrate the multi-channel routing scheme. We expect several advantages including the elimination of channel negotiation, channel scanning, and clock synchronization. Along with advantages, we also discussed issues

related to the proposed multi-channel scheme, i.e., efficiency, the channel convergence problem, the frequent channel switching problem, power saving, asymmetric links, and channel errors. Some issues are discussed in the following chapters, and the other issues are left for the future research.

## Chapter 5 Channel Distribution

Utilization of multiple channels in ad-hoc networks provides the benefits of increasing network capacity and increasing efficiency by reducing the probability of collisions. Multi-channel schemes are becoming more attractive as the cost of transceivers decreases and the capacity requirements for potential ad-hoc network applications increase. However, channel assignment mechanisms may distribute channels unfairly to different nodes, thus leading to inefficient use of available capacity and creating system bottlenecks. As discussed in Section 4.6.2, channels can be unfairly distributed due to the channel convergence problem even though they are fairly distributed initially. If channels are distributed unfairly, the proposed multi-channel routing scheme is not able to exploit multiple channels efficiently and, as a result, the available network capacity cannot be fully utilized.

In this chapter, we present a new metric to explore channel distribution in multi-channel wireless ad-hoc networks. The approach lets each node measure the fairness of channel distribution among neighboring nodes. The Channel Distribution Index (CDI) indicates the fairness of channel distribution in a multi-channel network. Each node in a network calculates the CDI based on the channel information available to it [59].

After identifying the channel convergence problem using a wireless sensor network model, we present a channel reallocation scheme to mitigate the effects of the channel convergence problem. The channel reallocation scheme enables nodes to adapt to changes in the network topology and traffic characteristics.

## 5.1 Motivation

Multi-channel schemes proposed in the past can be broadly categorized based on the schemes used for control messages and channel assignment. Some prior research proposes a dedicated control channel scheme to negotiate channel assignment [24, 25, 27, 30, 32, 34], while other research proposes a common period to share control messages [19, 21]. Both schemes use channel negotiation for channel assignment. Other research has shown that channel negotiation and time synchronization can preclude the efficient utilization of multiple channels [28, 53, 54, 60]. Simulation of channel assignment schemes that do not employ channel negotiation has yielded positive results.

In multi-channel networks, channels can be unfairly assigned to nodes in a network. The channel convergence problem, described in Section 4.6.2, can lead to the unfair channel distribution. In non-negotiation schemes [28, 53, 54, 60], the data channel of the transmitting or receiving node is determined according to the transmitting (TCA) or receiving node's data channel (RCA). Therefore, data channels used by nodes located along the path to a destination can converge and, as a result, the multiple channels cannot be fully utilized. Even in channel negotiation schemes [3, 25, 27], channels can be unfairly distributed if the channel negotiation criteria do not consider the distribution and utilization of the available channels.

Most prior work on multi-channel schemes focuses on the channel assignment (CA) problem and multi-channel multiple access control (MAC) protocols. This past work ignored channel distribution and utilization among neighboring nodes and the associated fairness problem. In this chapter, a new metric is proposed to explore and characterize the channel distribution problem in wireless multiple-hop ad-hoc networks.

The Channel Distribution Index (CDI) indicates the fairness of channel distribution based on the dynamic channel use among neighboring nodes. Depending on the network topology and traffic pattern, the channel allocation can become unfair. This unfairness can cause certain channels to become congested, while other channels are lightly utilized or even idle. As a result, the unfairness in channel distribution can degrade network throughput, thus eliminating the benefits of multi-channel operation. This will become an important issue as multi-channel operation is more widely accepted due to the decreasing cost of transceivers and the growing requirements for increased throughput in wireless ad-hoc networks [59].

Research on channel distribution and fairness is needed to enable evaluation and optimization of the channel assignment schemes for multi-channel operation. In addition to evaluating channel assignment and MAC schemes with respect to fairness, nodes can calculate the CDI and use the results to reallocate channels to increase fairness and efficiency.

## **5.2 Channel Distribution Index (CDI)**

The CDI is the index of the fairness of channel distribution from the perspective of the individual node (as indicated by the local value of the CDI) or the network (as indicated

by the global value of the CDI). The CDI is calculated based on the channel information collected by individual node (local CDI) or the channel distribution in a network (global CDI). For the local CDI, each node in a network periodically calculates the fairness of channel distribution among neighbors using the channel information collected through the multi-channel routing extensions described in Chapter 4. The global CDI is computed based on the periodic collection of channel distribution information in a network, which can be used to evaluate and optimize the channel assignment scheme in a network.

The CDI indicates the dynamic channel distribution among neighboring nodes. Depending on the network topology and traffic patterns, a fewer channels than available can be used and as a result, the fairness of channel distribution can become poor. This unfairness can cause certain channels to be congested while other channels are idle. As a result, unfairness can degrade network throughput. Thus, nodes should reallocate channels when they detect a certain level of unfairness based on the CDI (local CDI). The channel reallocation scheme is discussed in Section 5.3.

### **5.2.1 Required Properties of the CDI**

The required properties of the CDI, adapted from the fairness index of Jain, Chiu, and Hawe [61, 62], are described below.

1. *Scale and metric independence*

The index should be independent of scale, i.e., the unit of measurement should not matter. For example, the CDI measured for 100, 300, and 500 nodes occupying each of three different channels should be the same as the CDI measured

for 1, 3, and 5 nodes using each of the three channels. We consider only the fairness of channel distribution regardless of throughput and delay. In the above example, although the network with 100, 300, and 500 nodes assigned to the channels can experience more congestion and delay than the network with 1, 3, and 5 nodes assigned to the channels, the CDI should be same for both cases.

## 2. *Continuity*

The index should be continuous. Any small change in channel allocation should create a proportional small change in the index value.

In addition to the above properties shared with the fairness index of Jain, Chiu, and Hawe [61, 62], we also consider the following issues for the CDI for the particular domain of multi-channel wireless ad-hoc networks.

## 3. *Unlimited number of nodes and a limited number of channels*

The index should be applicable to any number of nodes with a limited number of channels.

## 4. *Fewer nodes than channels*

In a sparse network, the number of neighboring nodes may be less than the number of available channels. The CDI should be calculated according to the number of neighboring nodes rather than the number of available channels if the number of neighboring nodes is less than the number of channels available. Otherwise, the CDI can incorrectly indicate unfairness as the calculation is based on the number of available channels, where some channels cannot be occupied.

## 5. *Bounds*

The index should be bounded between 0 and 1, inclusive, i.e., it should be a real number in the interval  $[0, 1]$ . A totally fair distribution should have a CDI of 1 and a totally unfair distribution should have a CDI of 0.

### 5.2.2 Definition of the CDI

The proposed definition of the CDI is different from the definition of the fairness index of Jain, Chiu, and Hawe [61, 62] in two key aspects.

First, the fairness index proposed in [61, 62] is for distributed systems where a set of resources is shared by a number of users. The fairness index considers the allocation of resources to contending users, thus, all available resource can be allocated and effectively used by a single user. However, the CDI for multi-channel wireless networks considers the allocation of data channels to contending nodes (users), where a single channel is allocated to one or more nodes. A single node can only use at most one data channel at a time, so there is no value in allocating one node more than one channel. Furthermore, if the number of nodes in a two-hop neighborhood is less than the number of available channels, some channels will be unused. These unused channels should not be reflected as unfairness in the CDI.

Secondly, in Jain, Chiu, and Hawe's work [61, 62], a totally fair allocation has a fairness of 1 and a totally unfair allocation (with all resources given to only one user) has a fairness of  $1/n$ , which is 0 in the limit as the number of users  $n$  tends to  $\infty$ . Since the number of channels is, in general, limited, the CDI cannot be bounded between 0 and 1 with an unlimited number of nodes and a limited number of channels if the Jain, Chiu, and Hawe's definition of fairness [61, 62] is used. The value of the CDI is bounded be-

tween 0 and 1 considering a limited number of channels (as shown later in Figure 5.2).

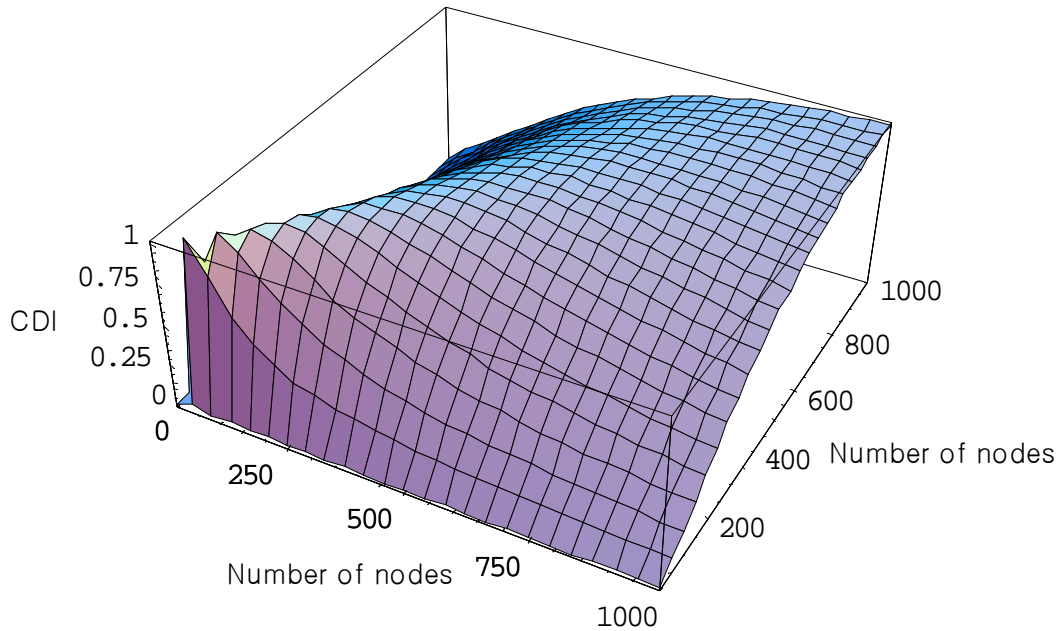
We define the CDI in Equation 1.

$$CDI C_i(x) = \frac{\frac{(\sum_{i=1}^k x_i)^2}{k(\sum_{i=1}^k x_i^2)} - \frac{1}{k}}{1 - \frac{1}{k}} = \frac{\frac{(\sum_{i=1}^k x_i)^2}{(\sum_{i=1}^k x_i^2)} - 1}{k - 1} \quad \begin{cases} n > 1 \\ k = m & \text{if } n > m \\ k = n & \text{if } n \leq m \end{cases} \quad (1)$$

Here,  $n$  is the number of available channels,  $m$  is the number of neighboring nodes including the current node, and  $x_i$  is the number of nodes in the two-hop neighborhood using the  $i$ th channel ( $m = \sum x_i$ ). The CDI ranges from 0 to 1 and is maximized when all channels are fairly distributed to neighboring nodes.

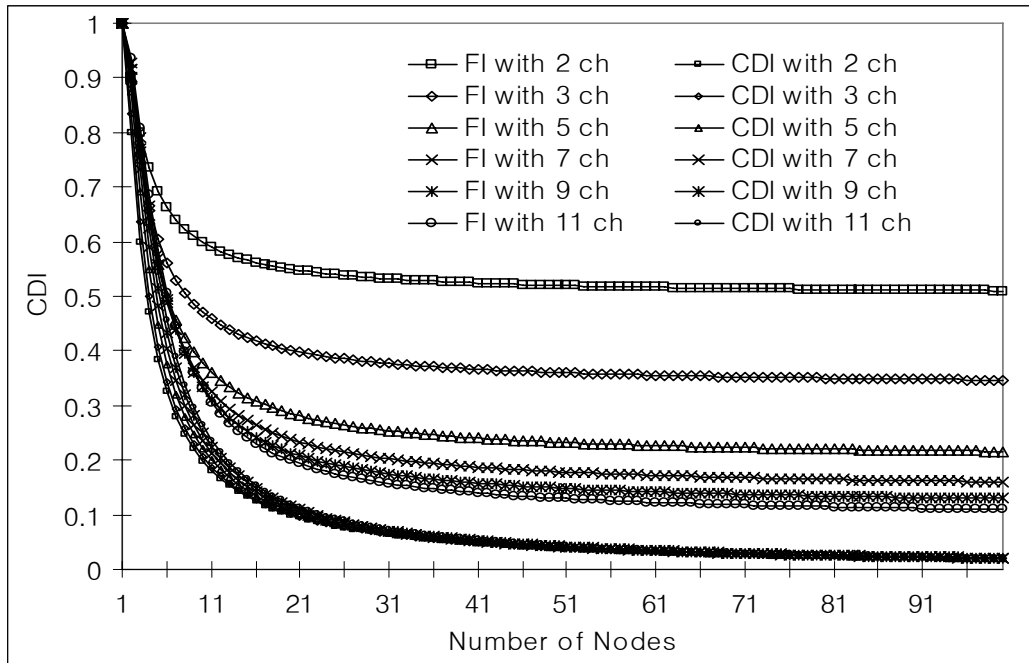
### 5.2.3 Continuity Analysis for CDI

Figure 5.1 shows the CDI where two channels are allocated to 1 to 1000 nodes. The number of nodes on each channel is shown indicated by the  $x$ -axis and the  $y$ -axis, while the CDI is shown on the  $z$ -axis. As indicated in the graph, the CDI varies from 0 to 1 and is continuous and well-behaved in the feasible range.



**Figure 5.1:** Illustration of the continuity of the CDI.

Figure 5.2 compares the bounds of the proposed CDI and Jain, Chiu, and Hawe's fairness index [61, 62] for different numbers of channels. The analysis is performed for the situation where the number of nodes using a particular channel increases, while all other channels are assigned to exactly one node each. If there are  $n$  channels and  $m$  nodes, with  $n \leq m$ , then exactly one channel is assigned to each of  $n-1$  nodes and the remaining one channel is assigned to  $m-n-1$  nodes. If  $n > m$ , then one node uses each of the  $n$  channels. The  $x$ -axis in Figure 5.2 denotes the number of nodes,  $m-n-1$ , sharing a single channel. As the number of nodes sharing the one channel increases, the unfairness also increases. The CDI is bounded between 0 and 1, while Jain, Chiu, and Hawe's fairness index [61, 62] is bounded between  $1/n$  and 1, where  $n$  is the number of channels.



**Figure 5.2:** Comparison the CDI and Jain, Chiu, and Hawe's fairness index.

### 5.3 Channel Reallocation

In multi-channel networks, channels can be unfairly assigned to nodes in a network as discussed in Section 5.1. In particular, the channel convergence problem described in Section 4.6.2 can lead to an unfair channel distribution. Depending on the network topology and traffic pattern, the channel allocation can become unfair. This unfairness can cause certain channels to become congested, while other channels are lightly utilized or even idle. As a result, the unfairness in channel distribution can degrade network throughput, thus eliminating the benefits of multi-channel operation.

In this section, we build on the channel distribution index and fairness issues discussed in Section 5.2, to identify the channel convergence problem using a wireless sensor network scenario and propose a channel reallocation scheme. The channel realloca-

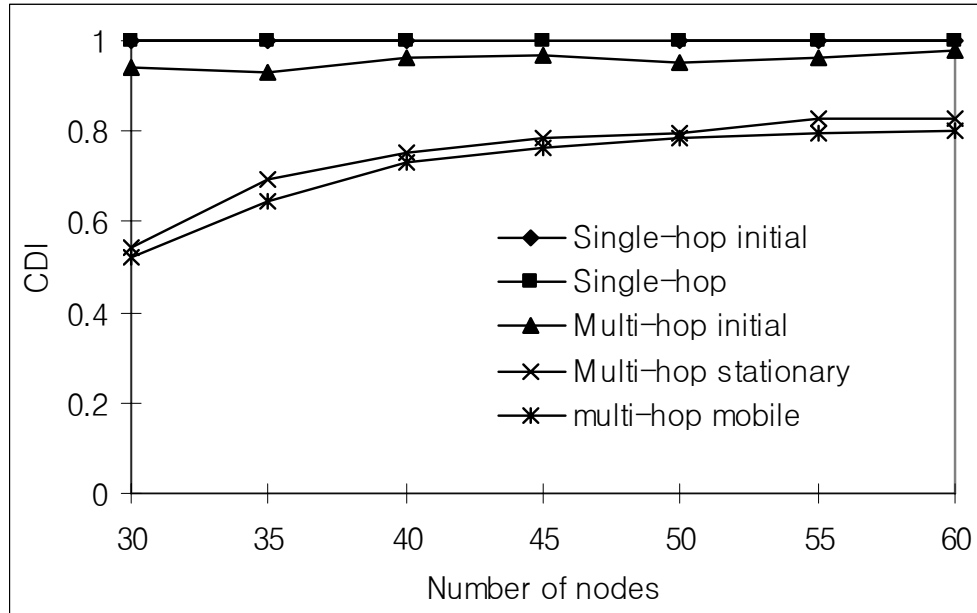
tion scheme enables nodes to adapt to changes in the channel distribution in the network resulting from changes in the network topology and traffic characteristics.

### 5.3.1 Simulations with Random Transmission

First, we perform simulations for random transmissions in single-hop and stationary and mobile multi-hop networks to investigate the unfair use of available channels. For a single-hop network, nodes are placed within each other's transmission range so that every source node can reach its destination node in a single hop. For a stationary multiple-hop network, nodes are randomly placed in a  $670 \text{ m} \times 670 \text{ m}$  square area and do not move. The random waypoint model [63] is used for the mobile multi-hop network model with a 1000-second warm-up period [64] and a maximum speed of 5 m/s. For all scenarios, one-half of the nodes are random sources and other half are random destinations, and a proactive multi-channel routing protocol, DSDV-MC, proposed in Chapter 4 is used.

Figure 5.3 shows the channel distribution index (CDI) in different network scenarios with random transmissions as the number of nodes increases. In a single-hop networks, the channel distribution is relatively fair ( $\text{CDI} \approx 1$ ) after both the initial channel allocation and transmissions, labeled as "single-hop initial" and "single-hop," respectively, in Figure 5.3. In multi-hop networks, the channel distribution becomes unfair after random transmissions due to the channel convergence in multi-hop connections. As a result, CDI decreases a bit from the initial allocation. (In the figure, "multi-hop initial" indicates CDI after initial allocation, "multi-hop stationary" is CDI after random transmissions in a stationary network, and "multi-hop mobile" is CDI after random transmissions in a mobile multi-hop network) However, the channel distribution is rela-

tively fair for all cases with random transmissions, as indicated by CDI values being close to one.

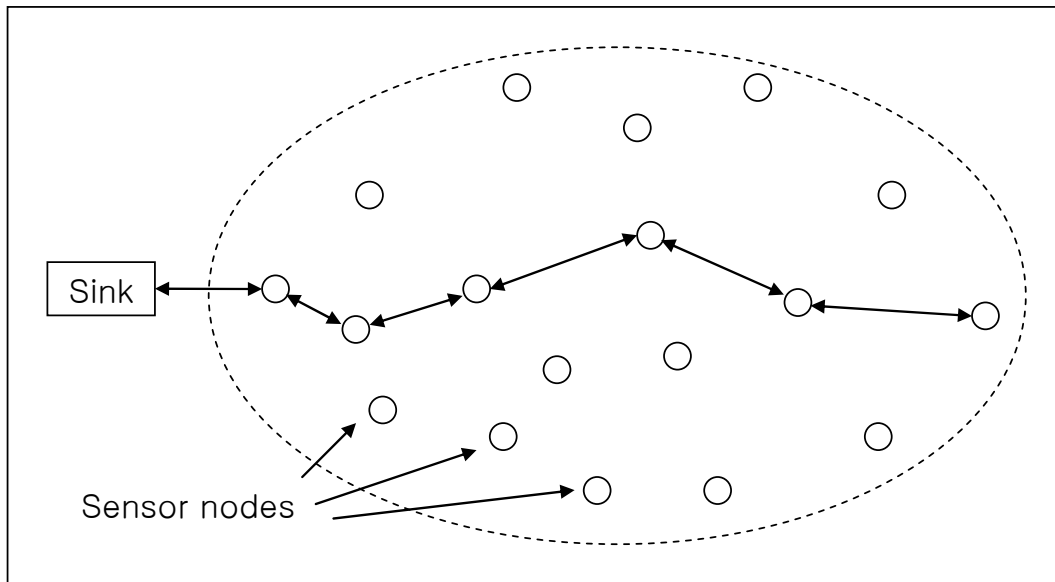


**Figure 5.3:** Channel distribution index after random exchanges.

### 5.3.2 Simulations with Channel Convergence

In this section, we investigate the channel distribution in a scenario exhibiting channel convergence, i.e., where transmissions converge to one or a small number of destination nodes. To illustrate the convergence problem, we consider a wireless sensor network. A wireless sensor network can, in practice, be composed of tens to thousands of wireless sensor nodes that are distributed across a wide area. These nodes form a network by communicating with each other either directly or indirectly through other nodes. In the model used here, one or more nodes serve as sink nodes that are capable of communicating with the other nodes, as shown in Figure 5.4 [36, 65].

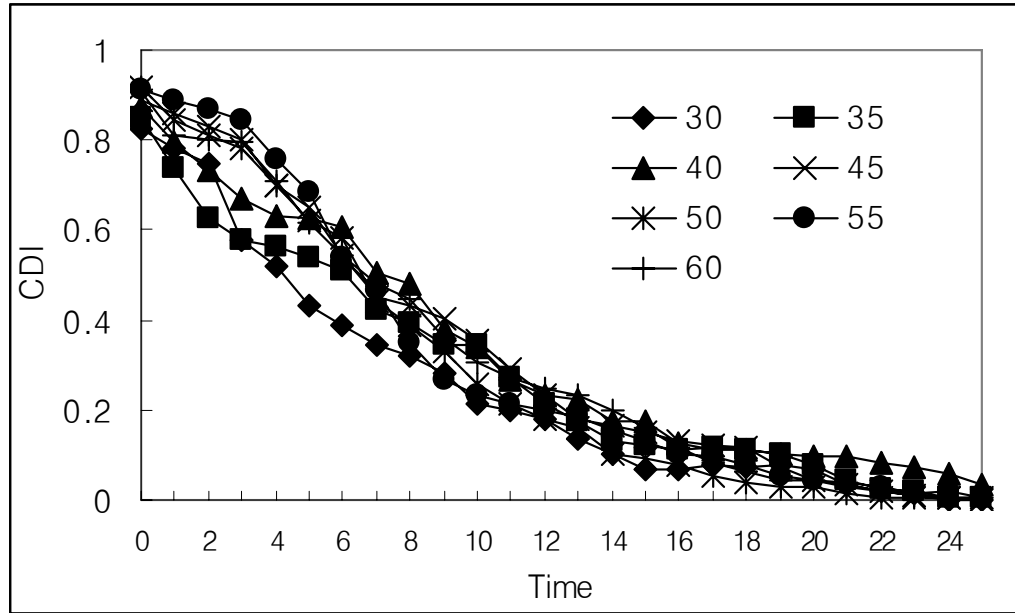
In general, there are two main common phases in a wireless sensor network. In the first phase, the measurement phase, area monitoring results in an accumulation of data at each sensor node. In the second phase, the data transfer phase, the collected data is transmitted to the processing center or intermediate nodes located within the sensor network. We model a sensor network as a collection of distributed nodes that issue queries and collect replies and results. The collection of nodes forms a stationary multi-hop network, and nodes transmit data to a single sink node, which results in the channel convergence problem.



**Figure 5.4:** Example wireless sensor network architecture.

For a stationary wireless sensor network simulation, nodes are randomly placed in a  $670 \text{ m} \times 670 \text{ m}$  square area and do not move. A proactive multi-channel routing protocol, DSDV-MC, proposed in Chapter 4 is used. A single node is designated as the sink node, and the rest of the nodes transmit to the sink node. Figure 5.5 shows the

channel distribution index as a function of time with different numbers of nodes in the network. As time progresses, nodes switch their data channel to the channel used by the associated sink (receiving) node to communicate and, eventually, all nodes share the single channel assigned to the sink node.



**Figure 5.5:** CDI values indicating the channel convergence problem.

As shown in Figure 5.5, the channel convergence problem is likely to occur in the wireless sensor network, which leads to unfair channel use. A wireless sensor network is one example network scenario that can induce the channel convergence problem. However, as discussed in Section 4.6.2, the channel convergence issue can occur, in general, with receiver-based or transmitter-based channel allocation schemes. Also, this problem can arise with negotiation-based channel allocation schemes unless properly designed. This unfairness in channel use can cause certain channels to become congested,

while other channels are lightly utilized or even idle. As a result, the unfairness in channel distribution can degrade network throughput, thus eliminating the benefits of multi-channel operation.

### 5.3.3 Channel Reallocation

As discussed in Section 3.2.4, the channel assignment can be static or dynamic. In static channel assignment, channels are assigned to each node and are used for the lifetime of the node in the network. In dynamic channel assignment, channels are assigned dynamically based on criteria such as signal strength, current channel use, or remaining battery life. Since the proposed multi-channel scheme based on RCA assigns channels during the initial phase, channels can be unfairly distributed and utilized as time goes on due to the characteristics of the RCA scheme. As a result, the channel convergence problem, as discussed in Section 4.6.2 and illustrated in Section 5.3.2, can occur.

To reduce the potential unfairness of channel distributions, we propose a channel reallocation scheme. The proposed channel reallocation scheme enables nodes to adapt to changes in the channel distribution due to changes in the network topology and traffic characteristics. A node using the channel reallocation scheme periodically determines the channel unfairness through the CDI. The reference index is proposed as a metric or “yardstick” to judge the fairness. A node defers its channel switch for a certain period since the channel distribution can be changed dynamically in an active network, which can diminish the problem of frequent channel changes.

**Variables** $m_1$ : number of 1-hop away neighbor nodes $m_2$ : number of 2-hop away neighbor nodes**Parameters** $n$ : number of available channels $t$ : time interval $T_{unfair}$ : Period of unfairness $C_{Ref}(x)$ : Reference index $C_l(x)$ : CDI**Function**

```

assign_chan() {
    get  $m_1$  from routing table
    if (the least used channels among  $m_1 > 1$ ) {           (1)
        get  $m_2$  from routing table
        if (the least used channels among  $m_2$  out of (1)  $> 1$ ) {   (2)
            choose randomly from (2)
        } else assign the least used channel
    } else assign the least channel
}

```

**Channel Reallocation()**

```

foreach  $t$ 
    get  $m_1$  from routing table
    if ( $m_1 < n$ )
         $n = m_1$ 
    compute  $C_l(x)$  with  $n$ 
    if  $C_l(x) < C_{Ref}(x)$  for  $T_{unfair}$ 
        assign_chan()

```

**Figure 5.6:** Pseudocode for the channel reassignment procedure.

The procedure for channel reallocation, based on the channel distribution, is shown in Figure 5.6.

The unfairness is determined by comparing CDI to a reference index ( $C_{Ref}$ ) for some period of time ( $T_{unfairness}$ ) since the unfairness can be temporary. If a node switches the working channel instantly after the detection of unfairness according to the CDI, unnecessary frequent channel updates can occur in a network where the CDI fluctuates frequently. If a node does decided to reallocate channel use, it recalculates the channel distribution to find the best channel at that moment, as described in Section 4.2.1.

With the proposed CDI, nodes are able to utilize a standardized reference threshold to determine the unfairness in a network. The reference index ( $C_{Ref}$ ) and the period of unfairness ( $T_{unfairness}$ ) should be configured according to the expected nature of the network topology and traffic pattern. (An adaptive reference index is discussed in Section 8.3. as potential future work.) In a network in which traffic flows are short lived and source-destination pairs change frequently and randomly, the period of unfairness ( $T_{unfairness}$ ) should be long enough to accommodate the frequent changes in traffic patterns. In addition, the reference index should be relatively higher, since the channel distribution is high with randomly distributed traffic. If the reference index is configured to be relatively high, the channels can be reallocated fairly. However, due to the high rate of reallocation, channel switching can occur frequently and, as a result, excessive overhead for channel switching and associated updates can occur.

Simulation experiments and results for the channel reallocation scheme are discussed in Chapter 6.

## 5.4 Summary

In this chapter, we presented the channel distribution index, a new metric to explore fairness in multi-channel wireless ad-hoc networks. Fairness in channel distribution, which results in a CDI value close to 1, implies that all channels are used equally. As a result, network capacity increases because channel resources are used efficiently. While most prior work focuses on the channel assignment problem and the multiple access control protocol for multi-channel operation, our study provides a method to evaluate the effectiveness of channel assignment and distribution among neighboring nodes.

Depending on the network topology and traffic pattern, only some of the available channels might be used, leading to unfairness. This unfairness can cause certain channels to be congested while other channels are idle. Unfairness can degrade network throughput. Thus, nodes should detect and react to such unfairness to ensure effective use of available capacity. The proposed CDI provides a means to evaluate unfairness. The continuity of the CDI and bounds on the CDI values were discussed to show that the proposed definition conforms to the required properties.

Along with research on channel distribution and fairness, we identified the channel convergence problem through a wireless sensor network scenario and proposed the channel reallocation scheme. The channel reallocation scheme enables nodes to adapt to changes of the channel distribution in the network according to the network topology and traffic characteristics.

To our knowledge, this is the first study of the fairness of channel distribution in multi-channel wireless ad-hoc networks. Future research can consider the use of the

CDI to guide channel reallocation to avoid the channel convergence problem demonstrated in this research.

## Chapter 6 Simulation Experiments and Results

We used simulation to verify the new protocol and to compare the performance of DSDV-MC and OSPF-MCDS-MC [53, 60]. This chapter introduces the new node model and corresponding application program interface (API) and discusses simulation results. Section 6.1 presents the modifications to the node model object and API. Section 6.2 discusses the simulation environment. Simulation results for DSDV-MC and OSPF-MCDS-MC are summarized in Sections 6.3 and 6.4, respectively. Simulation of channel reallocation with DSDV-MC is discussed in Section 6.3.3. Finally, Section 6.5 compares and discusses results.

### 6.1 Modifications to the Node Model Object

The wireless model in the Carnegie Mellon University (CMU) Monarch wireless extensions to ns2 essentially consists of the MobileNode object at its core, with additional supporting features that allow simulation of multiple-hop ad-hoc networks and wireless LANs [66]. (Note that the Monarch project is now based at Rice University.) The MobileNode object is a basic ns2 Node object with added functionalities, including the capability for movement and the ability to transmit and receive on a channel that allows it to

be used to create simulation models of mobile and wireless networks. A MobileNode object is created with an adhoc-routing agent and the network stack consisting of a link layer (LL), interface queue (IFq), MAC layer (MAC), and a network interface (netIF) with an antenna. The MobileNode object is described by the schematic in Figure 6.1.

The MobileNode object implemented in the current version of ns2 does not support multiple interfaces, so it cannot access multiple channels simultaneously. This capability is needed to simulate our proposed multi-channel scheme.

For our simulation, we introduce a new MobileNode object that can access multiple channels concurrently. The new MobileNode object supports multiple interfaces. However, the MobileNode object in our model uses just two interfaces since we assume two physical interfaces for each mobile node. The network stack in the new MobileNode model consists of a link layer and ARP module connected to LL, an interface priority queue, a MAC layer, and a network interface for each network protocol stack. These components are connected to the channel using the same propagation model as in the original MobileNode object. The new MobileNode object is described by the schematic in Figure 6.2.

We, also, introduce a new API along with the new MobileNode object. The new API provides the new MobileNode object with the channel switch function. The API receives the channel index as a parameter and provides a way to unlink old channels from the physical layer and link a new channel. The proposed API unlinks wireless channel from NetIF and links new wireless channel to NetIF, as illustrated in Figure 6.2.

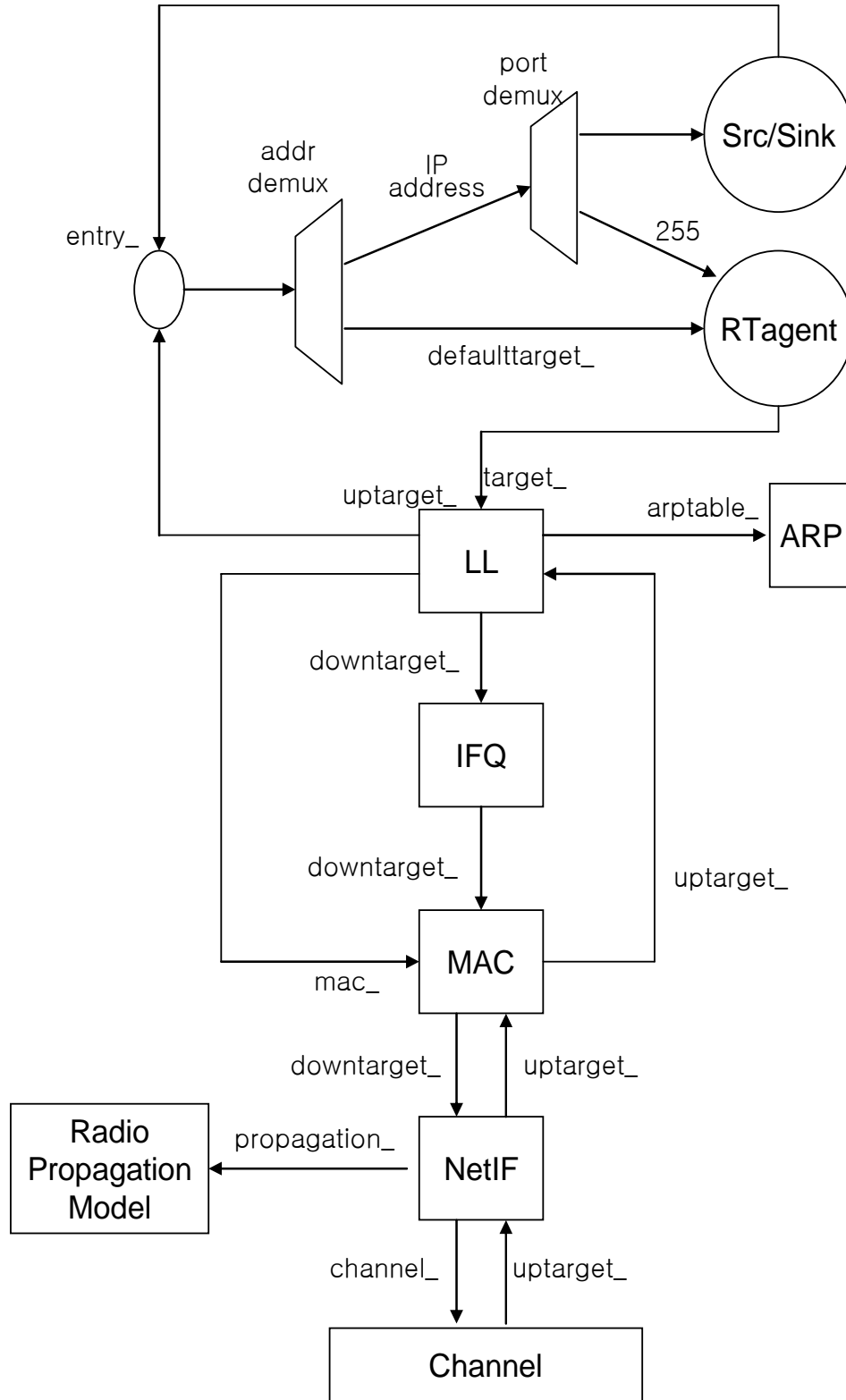
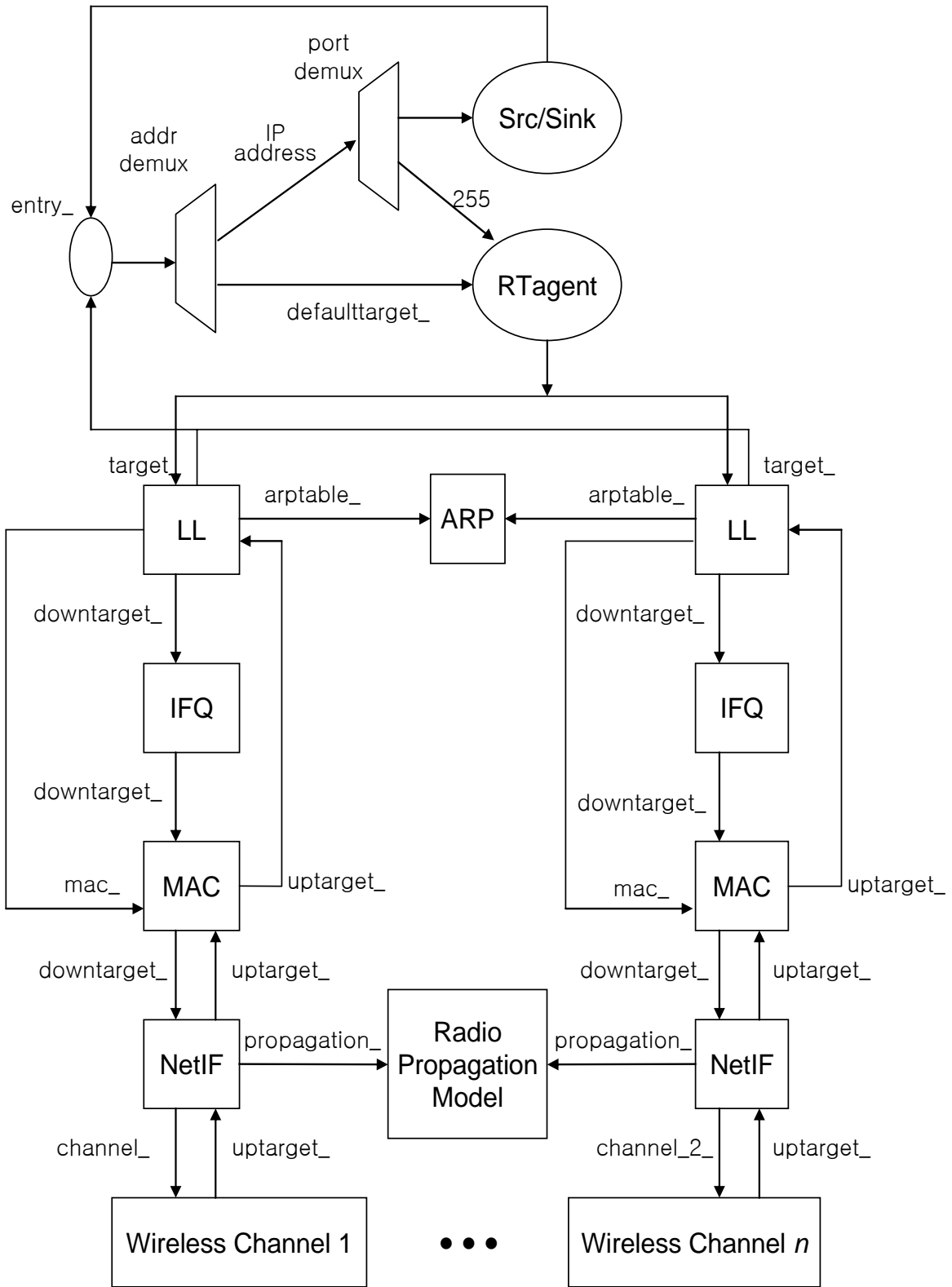


Figure 6.1: Schematic of a MobileNode object in ns2 [67].



**Figure 6.2:** Schematic of the modified MobileNode object.

## 6.2 Simulation Experiments

We perform simulation experiments using the ns2 simulator [66] with the CMU wireless extension [67] and the modified NodeModel object described in Section 6.1. The bit rate for each channel is 2 Mbps and the transmission range of each node is configured to be approximately 250 m. Each source node generates and transmits constant bit rate (CBR) traffic. We run each simulation for 200 seconds of simulated time. Each data point in the results is the average of 30 replications with different random seeds. Unless otherwise specified, the packet size is 512 bytes and the packet arrival rate from each node is 50 packets per second. The free space model [66] is used for the propagation model. To study the impact of these factors, we also perform simulations with varying parameter values.

Simulation experiments are performed for both single-hop and multiple-hop network scenarios. For the single-hop network simulations, all nodes are within the transmission range of all other nodes, thus every source node can reach its destination node in a single hop. For each scenario, half of the nodes are data sources and the other half are data destinations. We consider both stationary and mobile ad-hoc networks for the multiple-hop network scenarios. In the simulation of stationary nodes, nodes are randomly placed in a  $670 \text{ m} \times 670 \text{ m}$  square area and do not move. In cases where node mobility is considered, the random waypoint model [63] is used with a 1000-second warm-up period [64] and a maximum node speed of 5 m/s.

We use the goodput as a performance metric for simulation results. The goodput is the number of bits of user-level (above the network layer) information delivered over

the medium. This measure includes neither packet headers nor overheads and, thus, is useful for measuring the performance as seen by higher layer protocols. The goodput is calculated as the total number of information bits received at the destination divided by the simulation time.

## 6.3 Results for DSDV-MC

This section presents and briefly discusses simulation results for DSDV- MC. Section 6.3.1 describes the results for a single-hop network, Section 6.3.2 presents the results for multiple-hop networks, and Section 6.3.3 discusses the results for the channel reallocation scheme.

### 6.3.1 Results for Single-Hop Networks

To investigate network capacity, we compare the goodput while varying the number of available channels and the number of nodes. Figure 6.3 shows the goodput of DSDV and DSDV-MC routing protocols for different numbers of nodes and different numbers of channels. (In the figure, DSDV-MC- $n$  indicates DSDV-MC used with  $n$  channels.) As the number of nodes increases, the goodput of DSDV-MC increases in proportion to the number of available channels. As a result, the network saturation point increases as the number of channels increases, i.e., network capacity increases as the number of channels increases.

Figure 6.4 shows the packet drop rate. Since packets are distributed to more channels as the number of data channels increases, the packet drop rate decreases significantly as the number of channels increases. The goodput of the network also increases

in a multi-channel environment as the number of nodes increases.

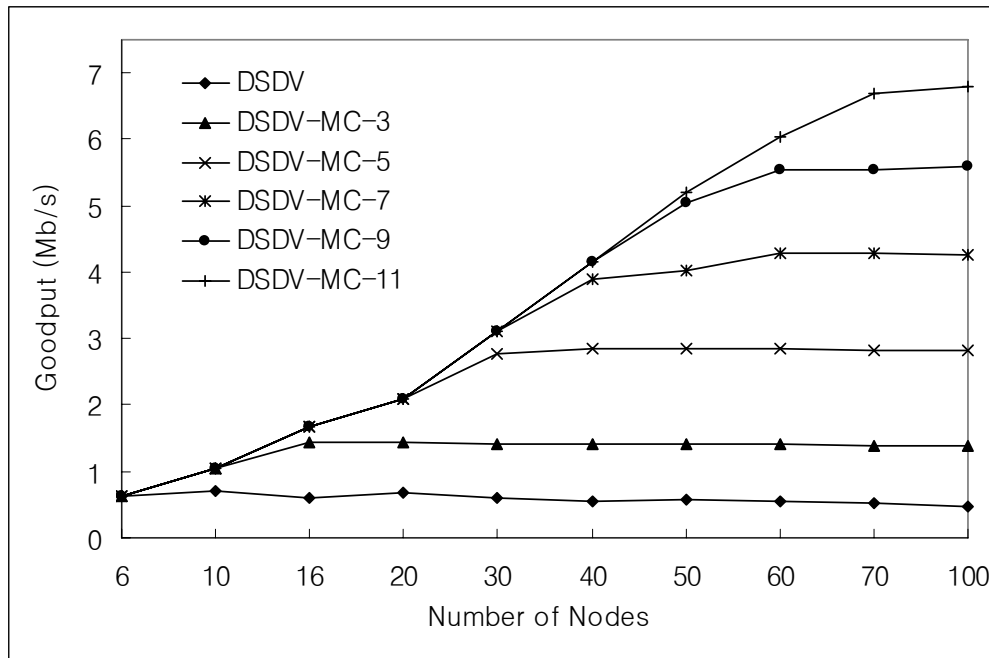
In a single-channel network, as used with standard DSDV, the drop rate increases sharply as the network becomes congested and more routing messages are likely to be dropped since routing messages and control packets share a single channel. Although DSDV-MC requires additional overhead to advertise channel information along with routing information, the number of routing packets in the network is close to that for the single channel case, as shown in Figure 6.5, since routing packets are exchanged through the common control channel.

Figure 6.6 shows the goodput for different numbers of channels and different packet sizes. We vary the packet size from 100 to 1000 bytes. Generally, the goodput is higher when the packet size is larger mainly because there is less control overhead. With larger packets, a larger amount of data is sent for each RTS/CTS exchange and, thus, contention for the channel occurs less frequently.

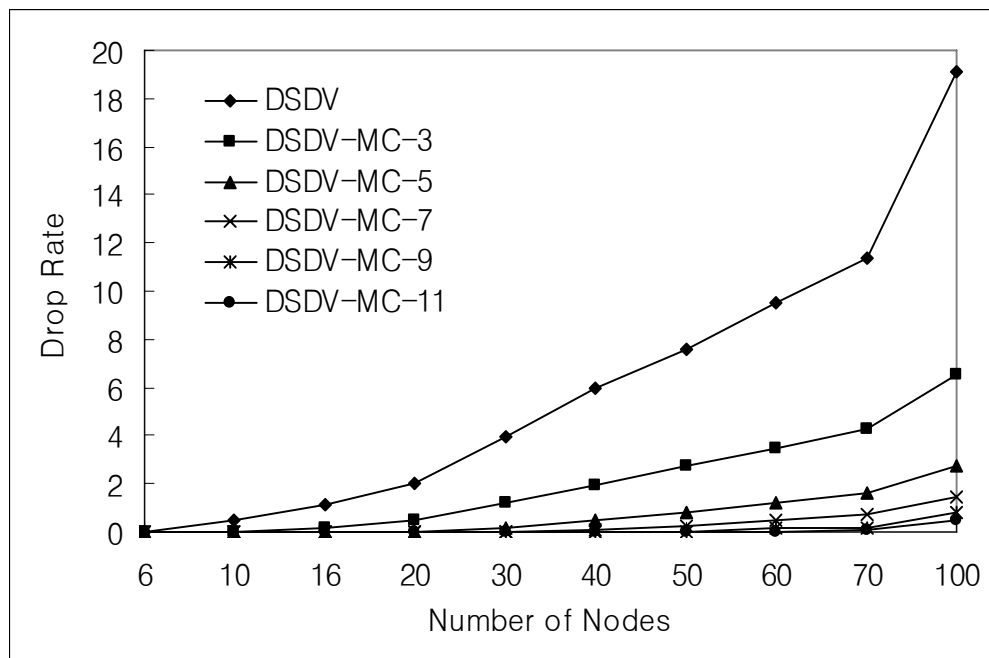
When the packet size is small, the control channel can become a bottleneck if a channel negotiation scheme is used [25]. However, since DSDV-MC does not require channel negotiation, the common control channel does not become a bottleneck. Therefore, the goodput of DSDV-MC does not increase sharply as the packet size increases.

We also measured the goodput of DSDV-MC when varying the packet arrival rate. The packet arrival rate is varied from 1 to 1000 packets per second at each node. The results in Figure 6.7 shows that the goodput of the network increases as the network load increases. The graph includes markers for the 95-percent confidence interval. While DCA [27] does not benefit from having additional channels when the number of channels becomes large due to control channel saturation, the simulation results show that our

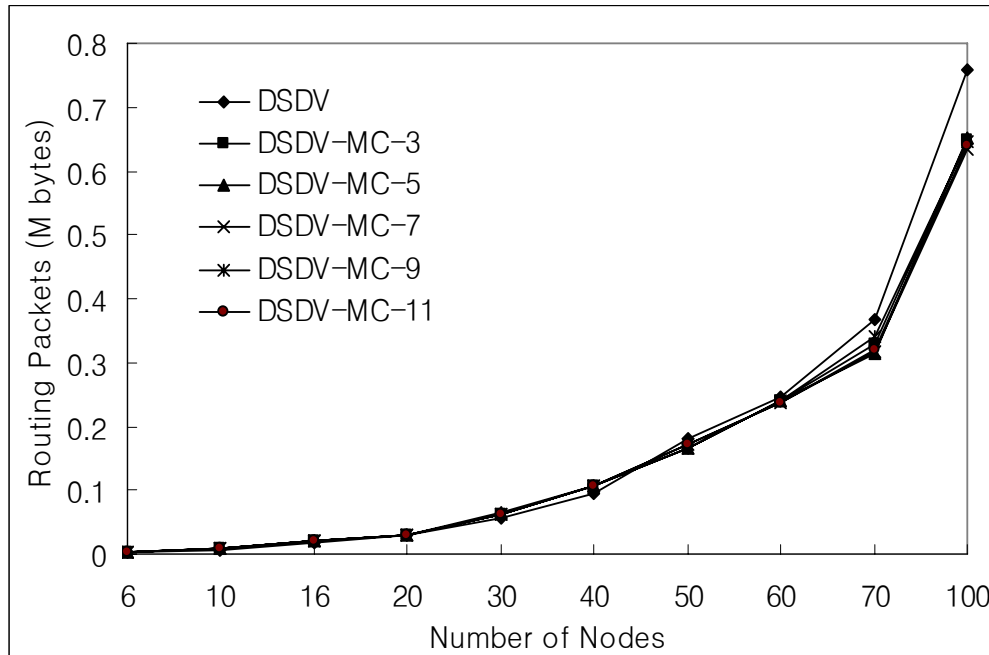
proposed scheme can fully utilize a relatively large number of channels.



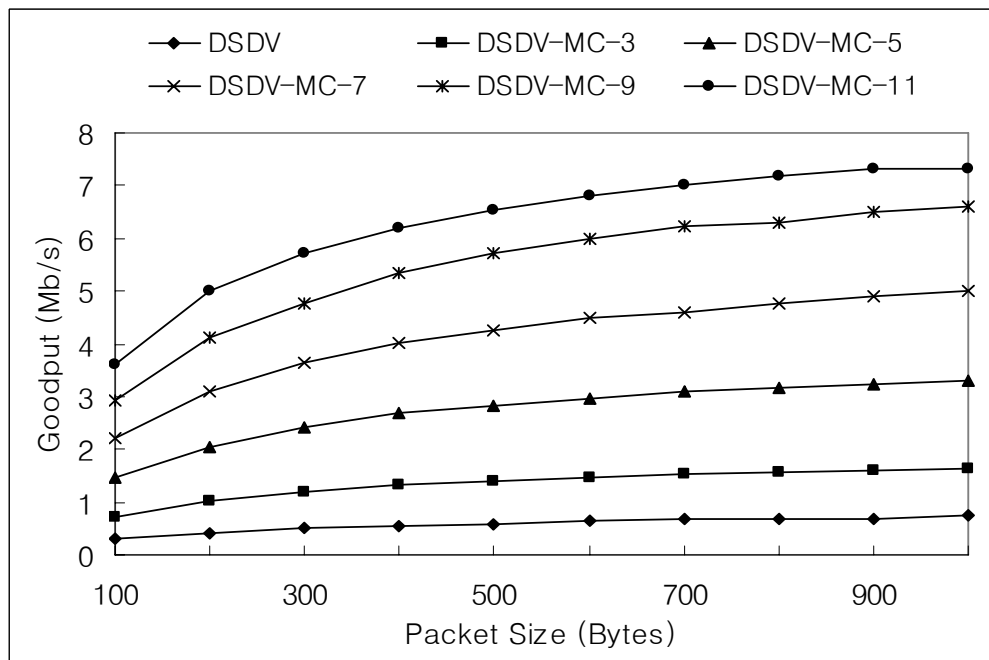
**Figure 6.3:** Goodput for single-hop network with varying numbers of nodes.



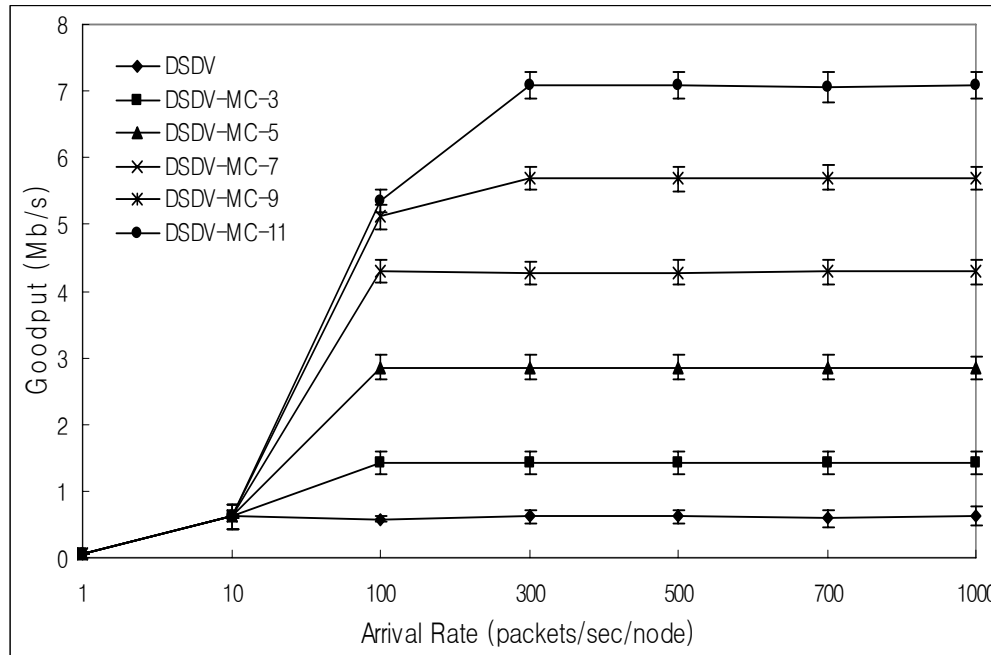
**Figure 6.4:** Packet drop rate for single-hop network with varying numbers of nodes.



**Figure 6.5:** Routing packets for single-hop network with varying numbers of nodes.



**Figure 6.6:** Goodput for single-hop network with varying packet size.

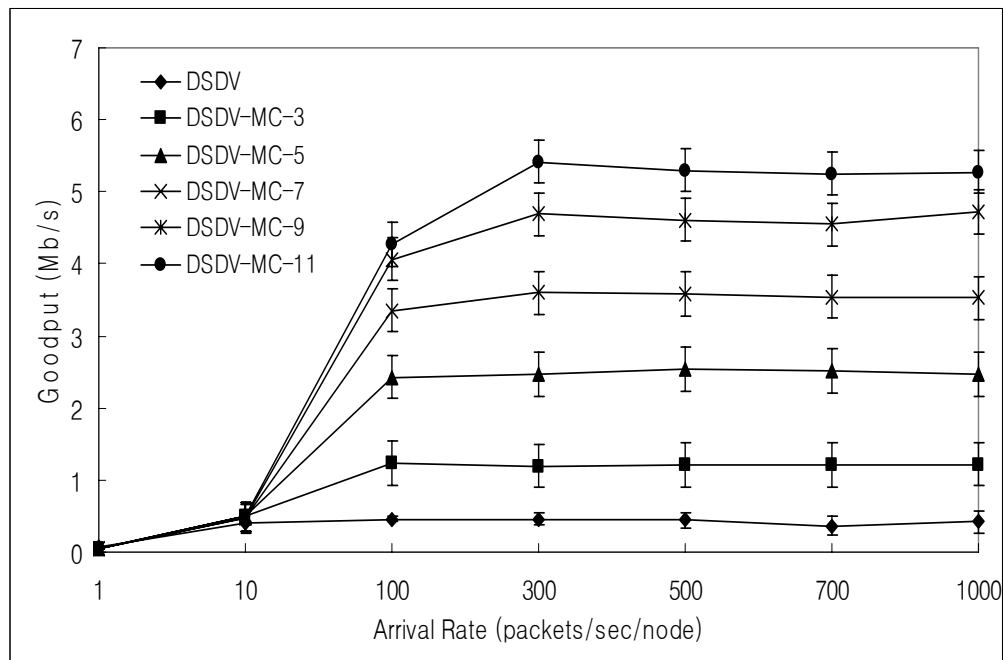


**Figure 6.7:** Goodput for single-hop network with varying packet arrival rate.

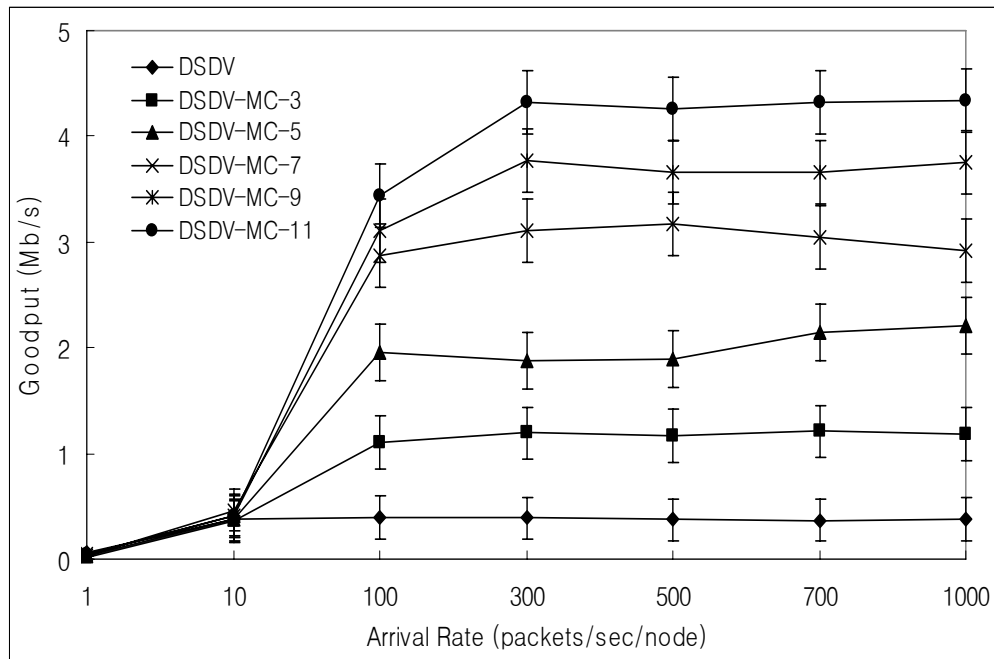
### 6.3.2 Results for Multiple-Hop Networks

For multiple-hop network experiments, we first compare the goodput for different packet arrival rates in stationary and mobile multiple-hop networks. Figures 6.8 and 6.9 show the goodput for DSDV-MC for different packet arrival rates in stationary and mobile multiple-hop networks, respectively. The plots include 95-percent confidence intervals. As the network load increases, the goodput of DSDV-MC increases in proportion to the number of channels. This indicates that the multi-channel routing scheme increases the network capacity even in a multiple-hop network. However, due to the multiple-hop routing and node mobility, the maximum goodput for DSDV-MC in both stationary and mobile configuration is lower than that for a single-hop network. Also, as may be inferred from Figures 6.8 and 6.9, the smaller confidence interval indicates that the stationary network has less variability in performance than the mobile network.

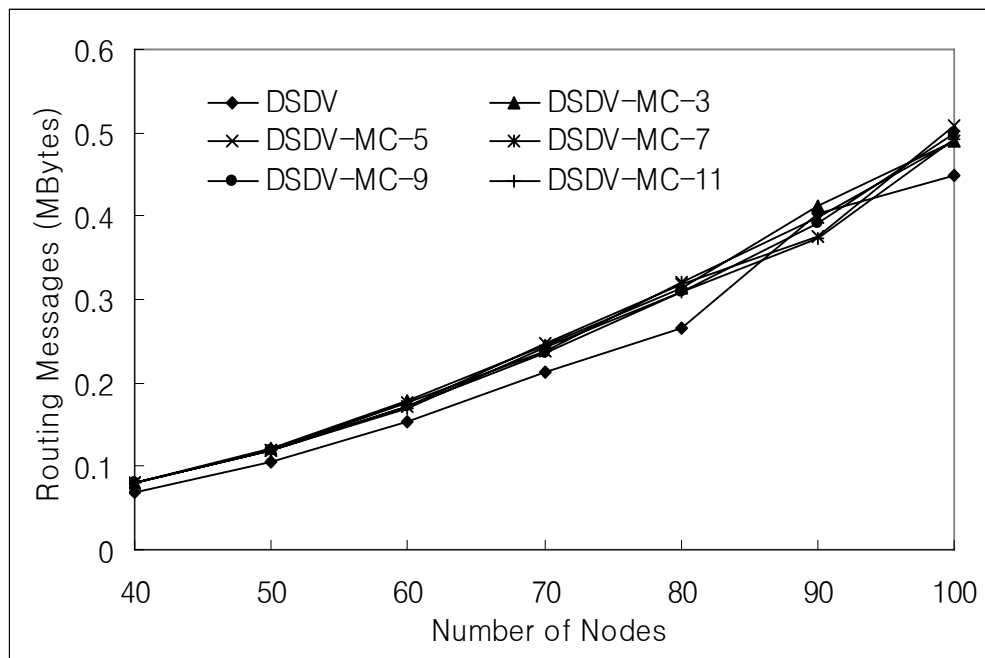
We compare the number of routing messages for different numbers of nodes in stationary and mobile multiple-hop networks. This simulation is done with the number of nodes varying from 40 to 100. Figures 6.10 and 6.11 show that the number of routing messages in a multiple-hop network is higher than in a single-hop network, as shown in Figure 6.5. This is due to the overhead of routing update messages, such as location and channel updates. In addition, the number of routing messages with the multi-channel scheme is slightly higher than for single-channel DSDV due to the overhead of channel updates in a multiple-hop network.



**Figure 6.8:** Goodput for varying packet arrival rates for a stationary multiple-hop network.

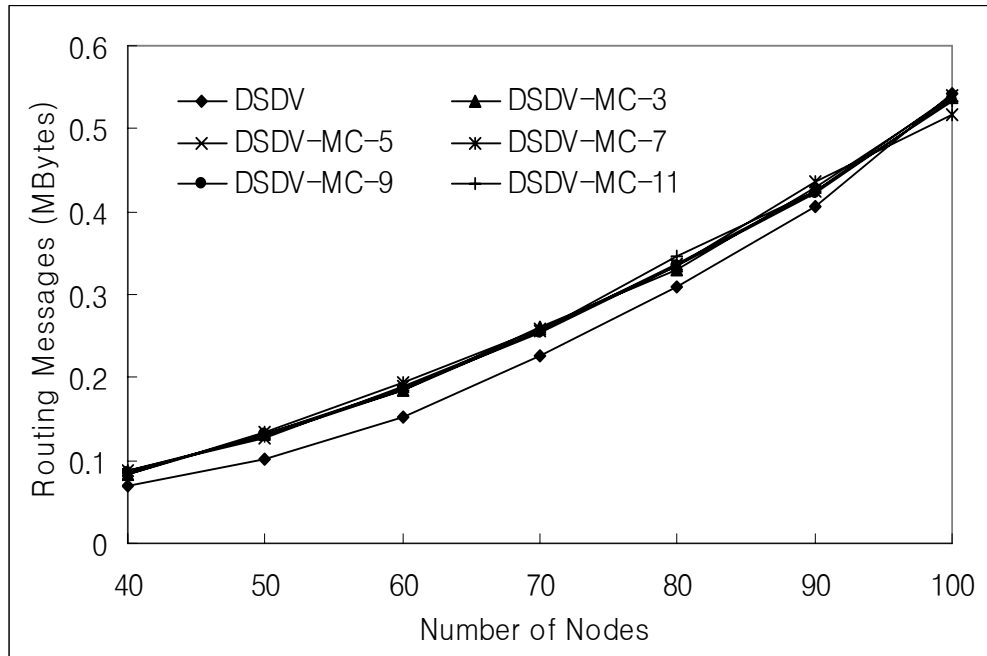


**Figure 6.9:** Goodput for varying packet arrival rates for a mobile multiple-hop network.



**Figure 6.10:** Number of routing messages for varying numbers of nodes

in a stationary multiple-hop network.



**Figure 6.11:** Number of routing messages for varying numbers of nodes in a mobile multiple-hop network.

### 6.3.3 Results for the Channel Reallocation Procedure

For simulation experiments investigating the channel reallocation scheme, experiments are performed with DSDV-MC-3 (DSDV-MC with three available channels) [60] under three network scenarios, linear, single-hop, and multi-hop networks. To demonstrate the channel convergence problem, we adopt a wireless sensor network scenario in which one or more of the nodes serve as sink nodes. Assuming one sink node, as time progresses, nodes switch their data channel to the associated receiving node to communicate and, eventually, all nodes share the single channel assigned to the sink node.

Simulation experiments with channel reallocation are performed using the ns2 simulator [66] with the CMU wireless extensions [67]. The bit rate for each channel is 2

Mbps and the transmission range of each node is approximately 250 m. Each source node generates and transmits CBR traffic. We run each simulation for 200 seconds of simulated time. Each data point in the results is the average of 30 replications with different random seeds. Unless otherwise specified, the packet size is 512 bytes and the packet arrival rate from each node is 50 packets per second.

For the simulation of a linear network, nodes are located such that a node can hear only two neighboring nodes. Nodes initiate transmission of CBR traffic destined to the sink node located at the far end of network after the initial channel allocation. For the single-hop network, nodes are placed within each other's transmission range, thus every source node can reach its destination node in a single hop. The sink node is placed randomly in a network and nodes start the transmission after the channels are distributed. For the multiple-hop network, nodes are interconnected with neighboring nodes so that packets from source to destination can traverse multiple nodes. Only a stationary scenario is simulated. The sink node is placed randomly in each network and nodes start transmission after channels are allocated.

For all scenarios, the simulation is performed with a reference index ( $C_{Ref}$ ) of 0.7 and a period of unfairness ( $T_{unfairness}$ ) of 10 seconds. We model a sensor network as a collection of distributed nodes. Nodes transmit data to a single sink node for all scenarios. To show the goodput and the channel distribution index, the simulation results are collected before and after the channels converge.

### 6.3.3.1 Results for the Linear Topology

First, we study the alteration of the channel distribution and the goodput in a linear net-

work scenario. Figure 6.12 indicates the CDI for varying numbers of nodes for the linear topology at different simulation points in times, specifically with the initial allocation in effect, after channel convergence occurs, and after channels are reallocated using the proposed scheme. After the initial channel allocation, the channels are allocated fairly amongst nodes in a network (labeled as “Initial Allocation” in Figure 6.12). However, after the transmission to the sink node, the CDI drops to zero due to the channel convergence problem (labeled as “Channel Convergence”). After the channel reallocation scheme is applied, nodes update their channel selection. As a result, the CDI increases (labeled as “Channel Reallocation”). The recovered CDI, however, is relatively low due to the interference with traffic unlike the initial allocation.

Figure 6.13 shows the goodput for varying numbers of nodes. “DSDV-MC-3” indicates the goodput of DSDV-MC with three channels under the same network topology. The curve labeled “DSDV” indicates the goodput of the single-channel network with the same network topology. “DSDV-MC-3 after Convergence” shows the goodput after channels are converged. As can be seen in Figure 6.13, the goodput of DSDV-MC with three channels after channel convergence is as low as that of DSDV since channels are all converged to the sink node’s data channel. With the channel reallocation scheme, the goodput can be increased to be close to that of DSDV-MC-3 after the initial allocation.

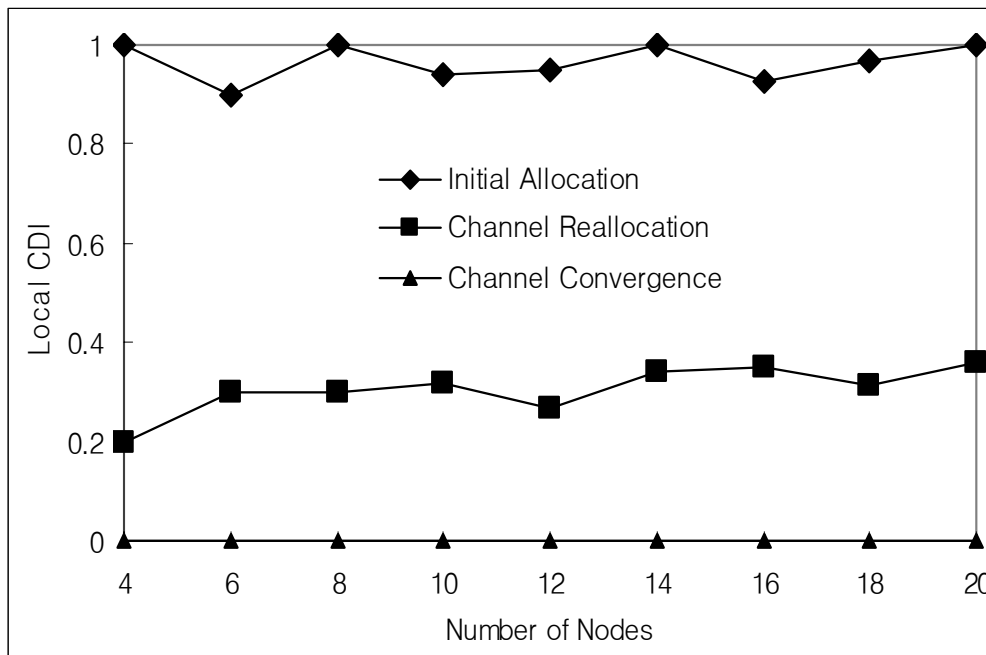


Figure 6.12: CDI for linear network for varying numbers of nodes.

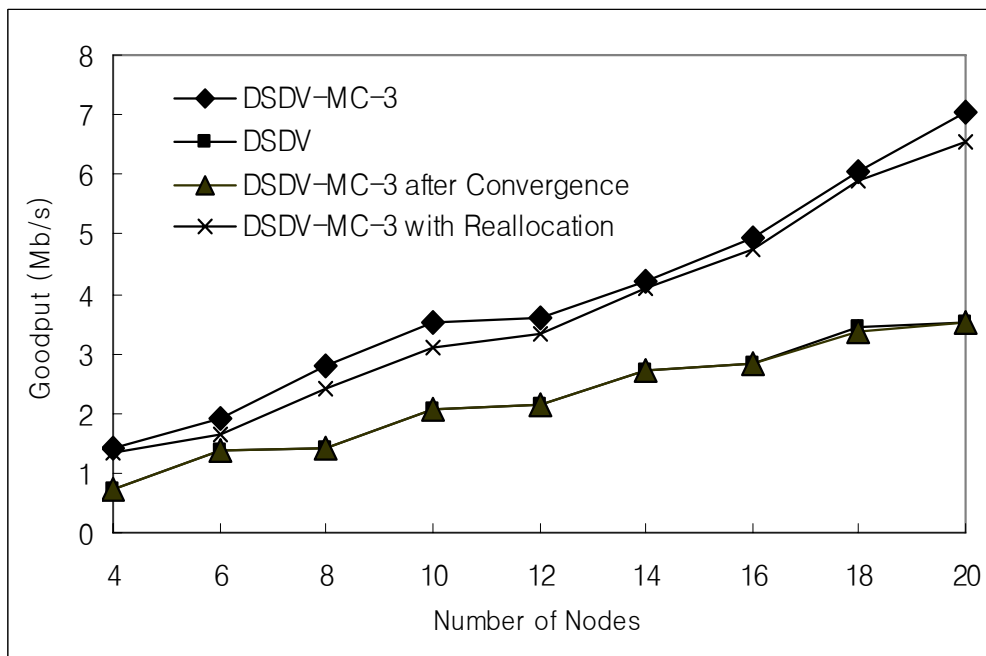
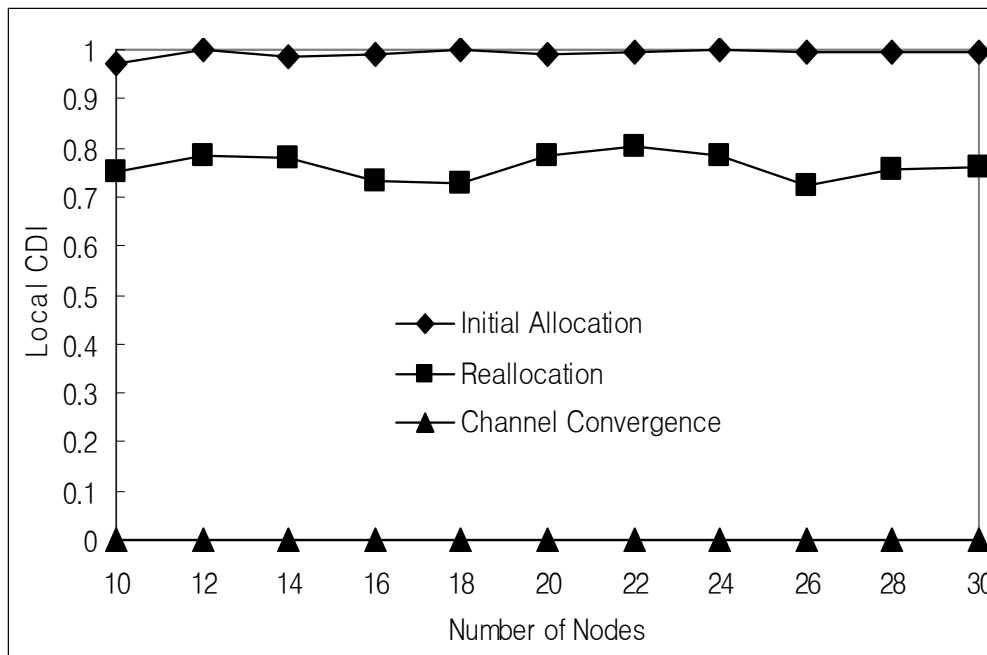


Figure 6.13: Goodput for linear network for varying numbers of nodes.

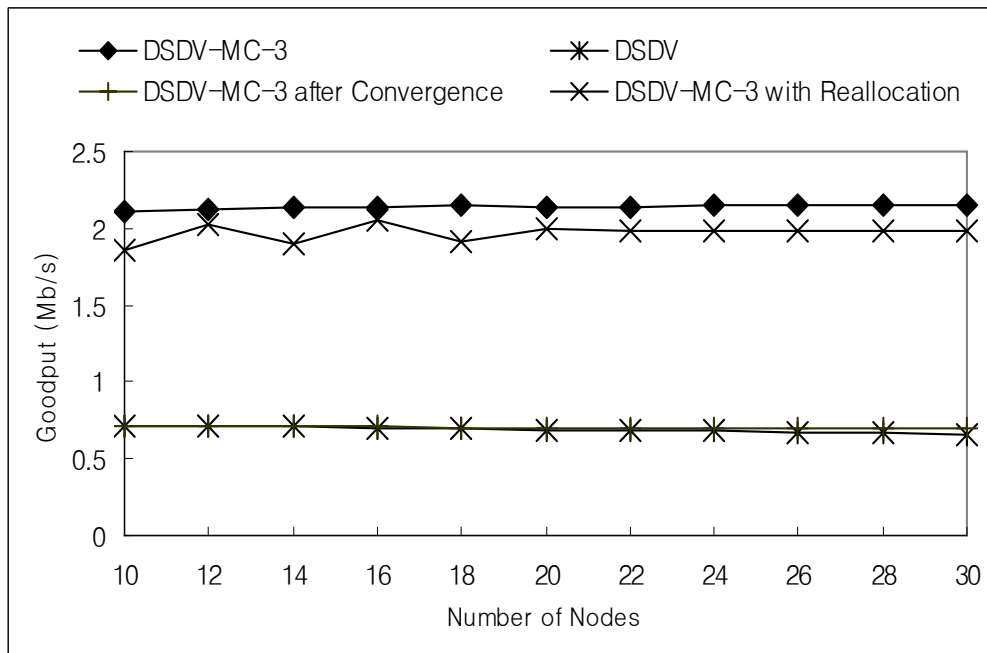
### 6.3.3.2 Results for the Single-Hop Network

Similarly, the channel distribution and the goodput are examined for a single-hop network scenario. Figure 6.14 shows the CDI for varying numbers of nodes at different points in time related to channel allocation for the single-hop network. Like the simulation results for the linear network, the CDI decreases to zero due to the channel convergence problem after the transmission to the sink node (labeled as “Channel Convergence” in Figure 6.14). The CDI increases to 0.8 after channel reallocation (labeled as “Reallocation”). We also note that the gain in the CDI is larger than that in the linear topology due to the characteristics of the network topology specifically that connections are all direct in a single-hop network.

Figure 6.15 illustrates the goodput for varying numbers of nodes. As the channel distribution converges, the goodput of the network drops as low as the goodput of the single-channel network. The goodput is improved to be close to the value at the initial allocation after the channel reallocation scheme is applied. We also note that the goodput of the network does not increase as the number of nodes increases as in the linear network since the network is already congested.



**Figure 6.14:** CDI for the single-hop network for varying numbers of nodes.



**Figure 6.15:** Goodput for the single-hop network for varying numbers of nodes.

### 6.3.3.3 Results for the Multiple-hop Network

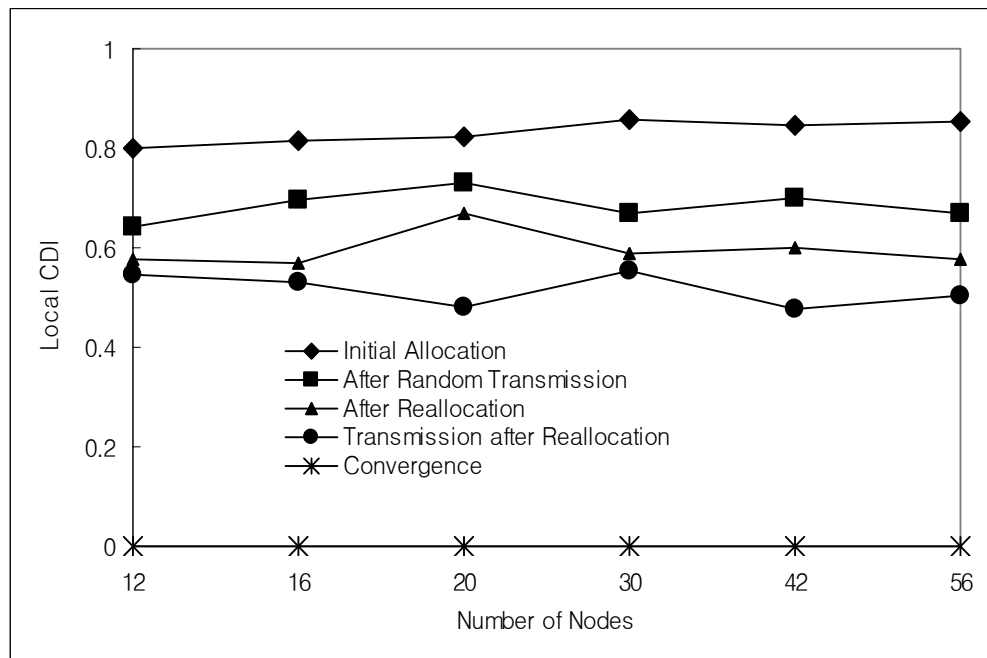
In addition to simulations for varying numbers of nodes, the goodput for varying reference index values is examined in the multiple-hop network scenario. Figure 6.16 shows the CDI for varying numbers of nodes at different points in time related to channel allocation for the multiple-hop network. To investigate the change in CDI, the simulations include random transmissions before beginning transmissions to the sink node. The curve labeled “Initial Allocation” indicates the CDI after initial channel allocation. The channel distribution decreases somewhat after the random transmission period, as indicated by the “After Random Transmission” curve. After the random transmission, the wireless sensor network traffic pattern is used, i.e., nodes transmit to a single sink node. The curve labeled “Convergence” shows the channel distribution after nodes transmit packets to the sink node. Due to the channel convergence problem, the channel distribution index becomes zero, which indicates total unfairness.

Figure 6.17 shows the goodput for varying numbers of nodes in a multiple-hop network. The goodput of DSDV-MC-3 after the channel convergence is as low as the goodput of single-channel DSDV. After the channel reallocation, the goodput increases. The results show that the goodput of a multiple-hop network is greater than that of a single-hop network.

Although the CDI increases due to the channel reallocation procedure, as indicated by the “After Reallocation” curve, the CDI does not increase to as high a level as with random transmission, as shown in Figure 6.16. The CDI decreases with random transmissions after channel reallocation, as indicated by the “Transmission after Reallocation” curve. This result suggests that the reference index value significantly affects the effec-

tiveness of the channel reallocation procedure. We simulate the frequency of channel reallocation as the reference index increases and investigate the relationship between the reference value and the goodput for the network.

The reference value is varied from 0.1 to 0.9. As seen in Figure 6.18, the goodput is at its peak with a reference index of about 0.5. Goodput drops significantly as the reference index increases beyond 0.5 since the higher reference index causes frequent channel reallocation as indicated in Figure 6.19. Figures 6.18 and 6.19 include indicators of the 95-percent confidence intervals.



**Figure 6.16:** CDI for multi-hop network for varying numbers of nodes.

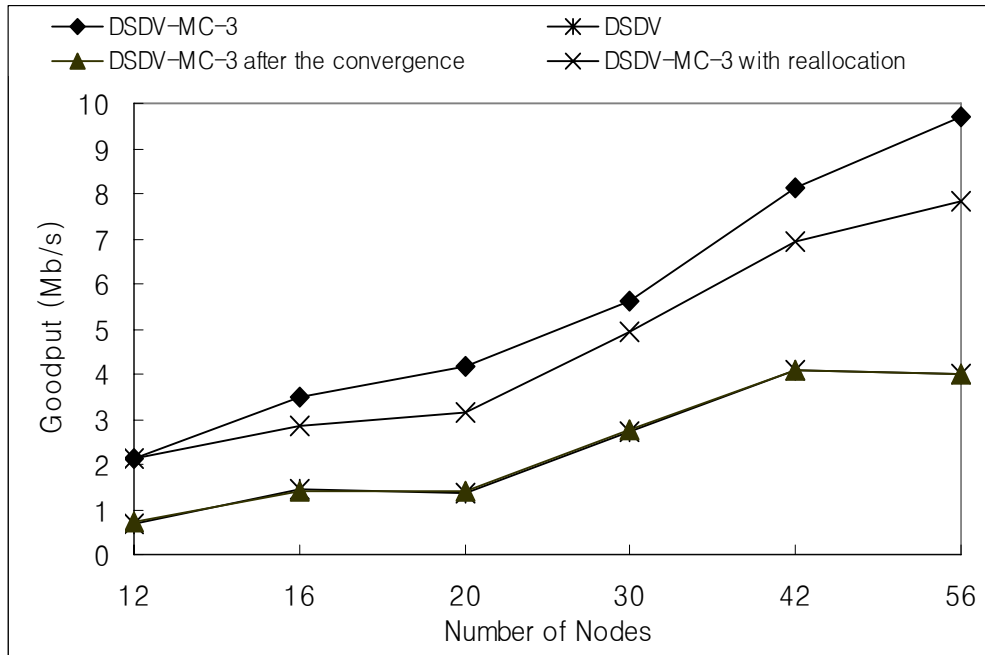


Figure 6.17: Goodput for multiple-hop network for varying numbers of nodes.

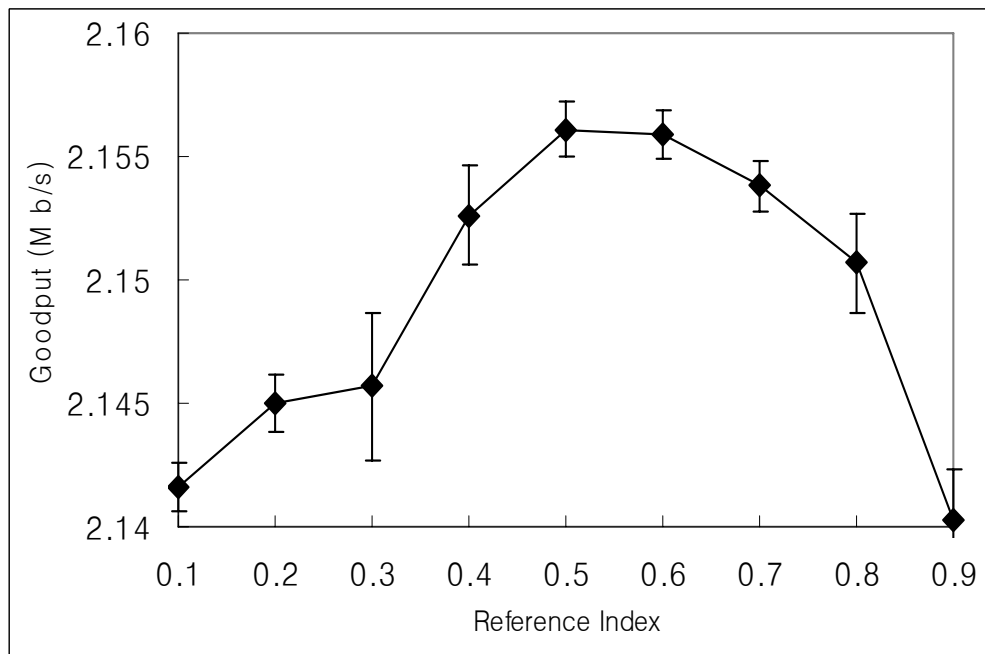
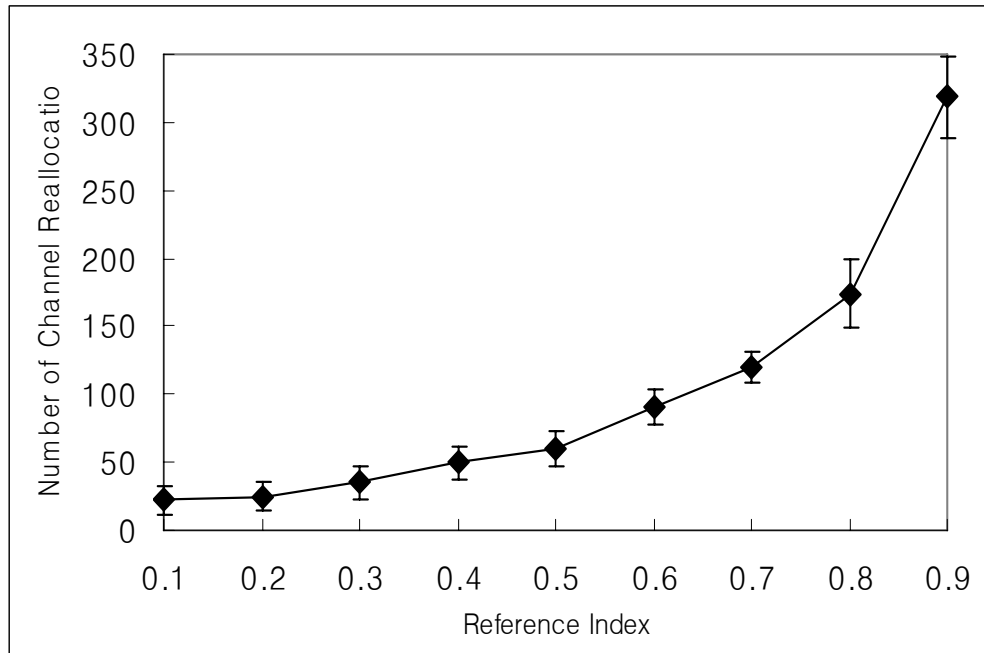


Figure 6.18: Goodput for multiple-hop network for varying reference index.



**Figure 6.19:** Frequency of channel reallocation in a multiple-hop network for varying reference index.

Since the optimum reference index can vary according to the network topology and traffic characteristics, the reference index should be adaptive. An adaptive reference index is discussed as possible future work in Section 8.3.

## 6.4 Results for OSPF-MCDS-MC

This section presents and briefly discusses simulation results for OSPF-MCDS-MC. Section 6.4.1 describes the results for a single-hop network and Section 6.4.2 presents the simulation results for multiple-hop networks.

### 6.4.1 Results for Single-Hop Networks

We first compare the proposed OSPF-MCDS-MC protocol with single-channel OSPF-

MCDS in a single-hop network. Figure 6.20 shows the goodput for OSPF-MCDS and OSPF-MCDS-MC routing protocols for different numbers of nodes and different numbers of channels. As the number of nodes increases, the goodput of OSPF-MCDS-MC increases as the number of available channels increases until a saturation point is reached. As a result, the network saturation point increases as the number of channels increases. In other words, network capacity increases as the number of channel increases.

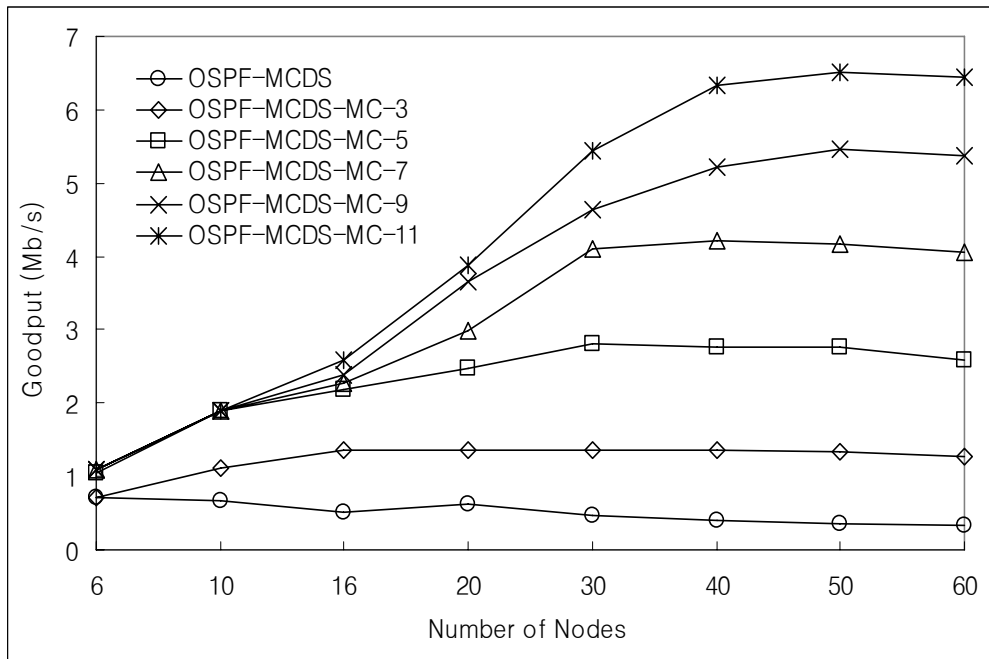
Figure 6.21 shows the packet drop rates corresponding to the simulation of Figure 6.20. Since packets are distributed to more channels as the number of data channels increases, the packet drop rate decreases significantly as the number of channels increases. The goodput of the network also increases in a multi-channel environment as the number of nodes increases.

To investigate the overhead of routing messages, we use the overall size of routing messages and the routing message ratio (RMR) as metrics. The RMR is defined as the ratio of routing messages to the offered load in the network. As seen in Figures 6.22 and 6.23, although OSPF-MCDS-MC requires additional overhead to advertise channel information along with routing information, the number of routing packets in the network is close to that for the single-channel case. However, in a single-channel network, the drop rate increases sharply as the network becomes congested and more routing messages are likely to be dropped since routing messages and control packets share a single channel. Therefore, after the network is saturated, the number of routing messages is likely to increase sharply. This is demonstrated in Figures 6.22 and 6.23 when the number of nodes increases and, in turn, the network load increases.

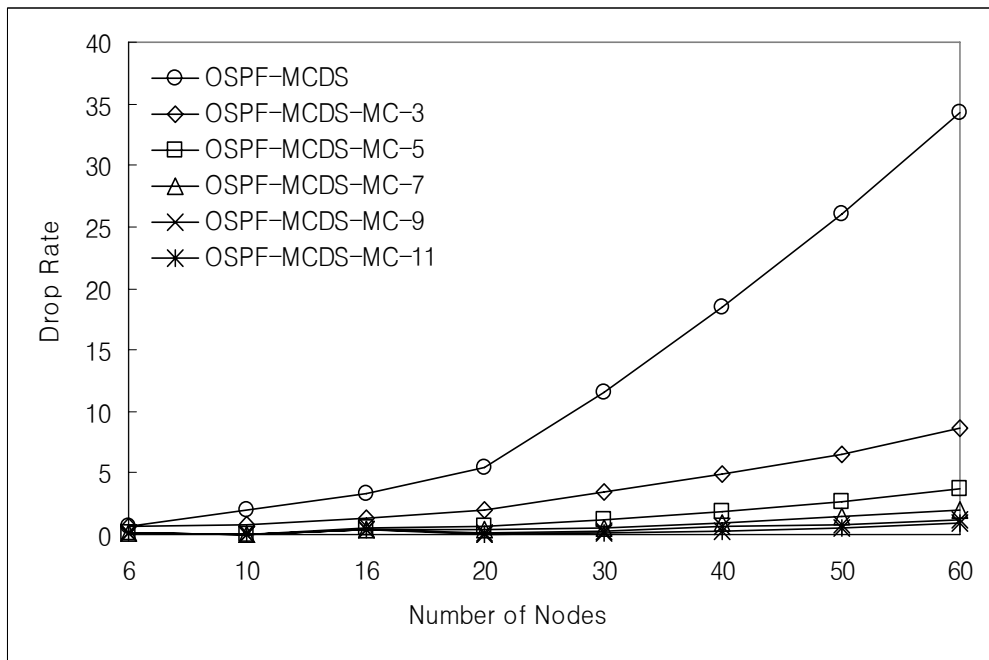
Figure 6.24 shows the impact of different numbers of channels and packet sizes on

the goodput. We varied the packet size from 100 to 1000 bytes. Generally, the goodput is higher when the packet size is larger mainly because there is a lower percentage of control overhead. When the packet length reaches the RTS/CTS threshold, a larger amount of data is transmitted with RTS/CTS and, thus, contention for the channel occurs less frequently. When the packet size is small, the control channel can become a bottleneck if channel negotiation [24, 25, 27] occurs via the control channel. However, since OSPF-MCDS-MC does not require channel negotiation, the common control channel does not become a bottleneck. Therefore, the goodput of OSPF-MCDS-MC does not increase sharply as the packet size increases.

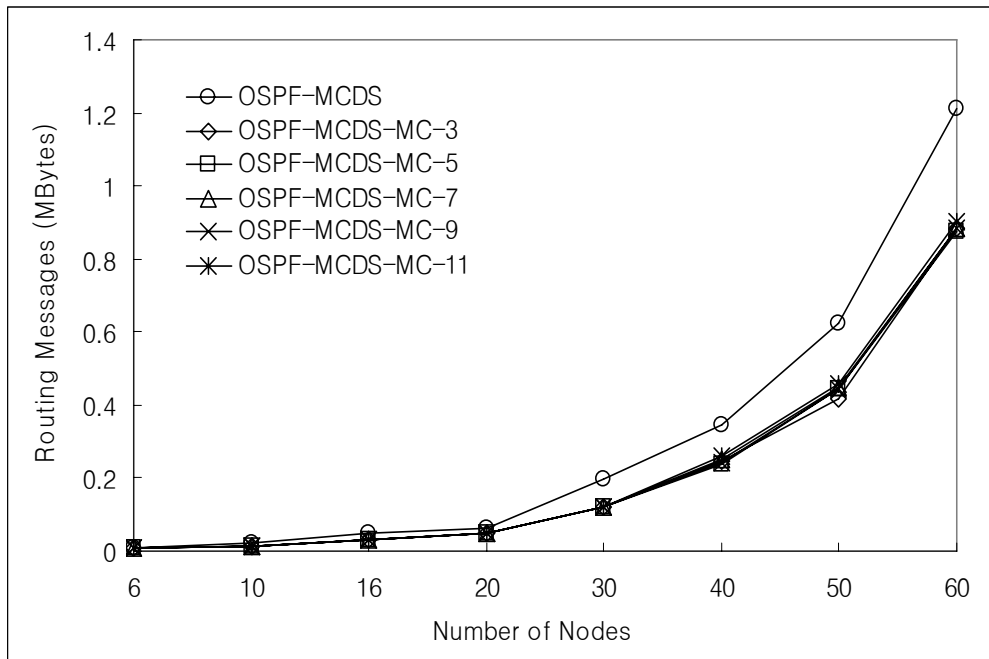
We also measured the goodput of OSPF-MCDS-MC while varying the packet arrival rate. The packet arrival rate is varied from 1 to 1000 packets per second at each node with 30 nodes. The results in Figure 6.25 indicate that the goodput of the network increases as the network load increases. The graph includes 95-percent confidence intervals. While a scheme with channel negotiation [24, 25, 27] does not benefit from having additional channels when the number of channels becomes large due to control channel saturation, simulation results shows that our proposed scheme efficiently utilizes an increased number of channels.



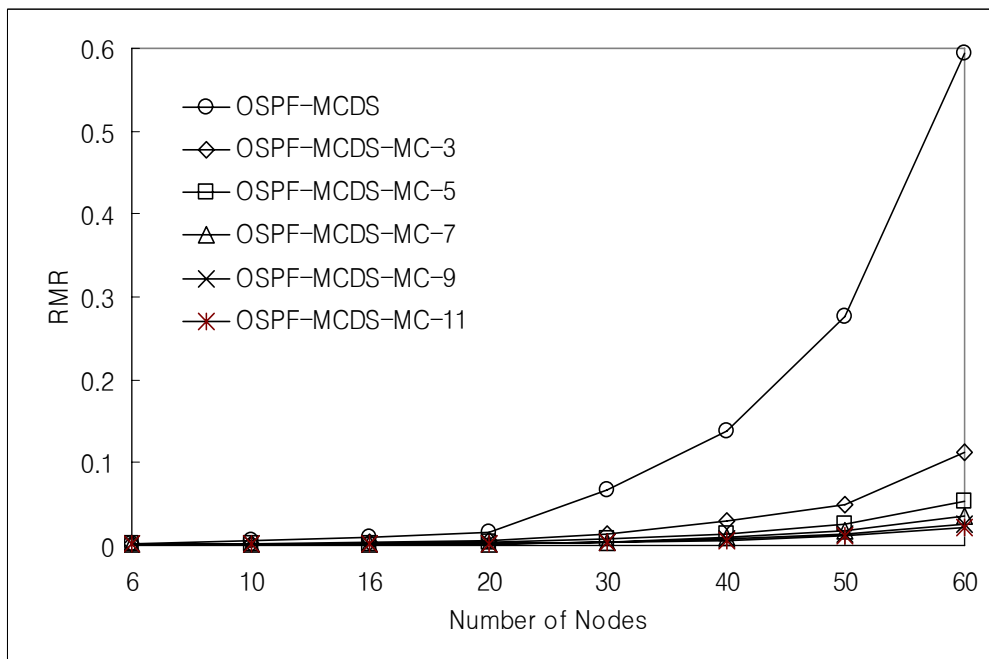
**Figure 6.20:** Goodput for single-hop network for varying numbers of nodes.



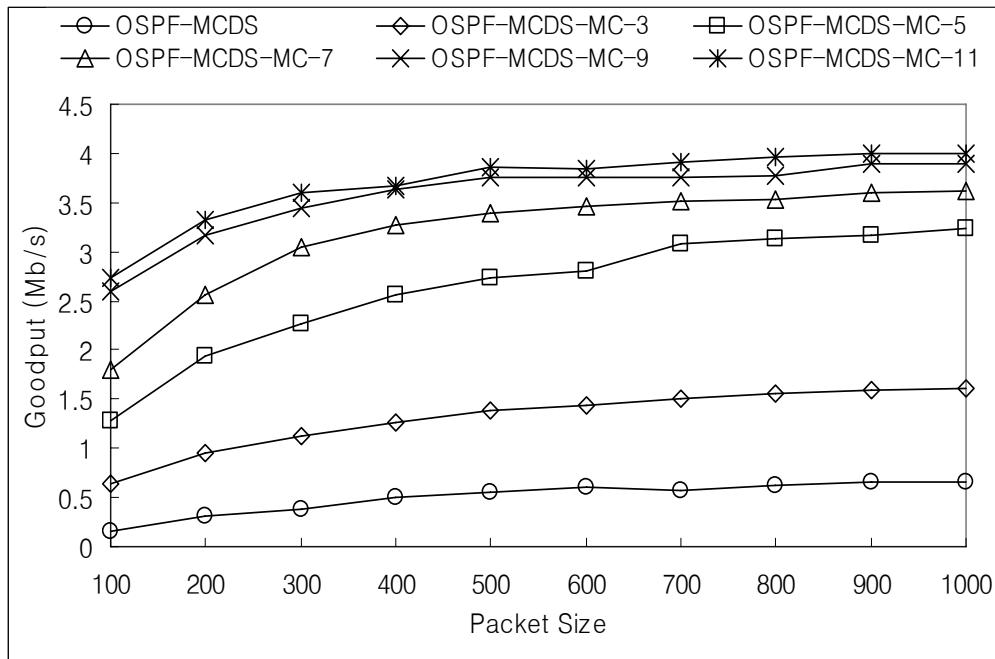
**Figure 6.21:** Packet drop rate for single-hop network for varying numbers of nodes.



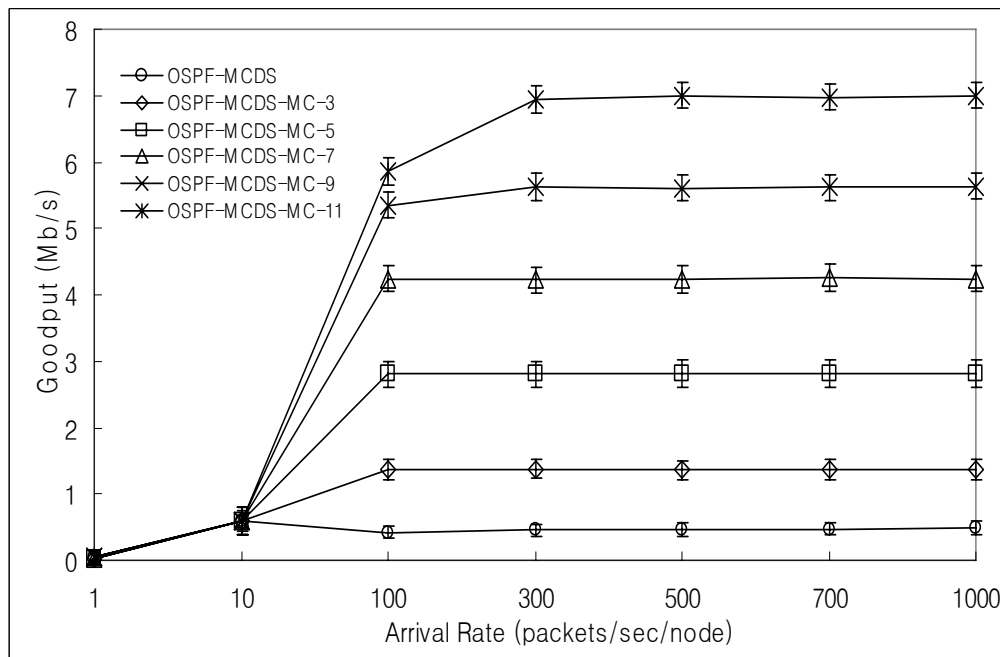
**Figure 6.22:** Routing messages for single-hop network for different numbers of channels and different numbers of nodes.



**Figure 6.23:** RMR for single-hop network for different numbers of channels and different numbers of nodes.



**Figure 6.24:** Goodput for single-hop network for varying packet size.



**Figure 6.25:** Goodput for single-hop network for varying packet arrival rate.

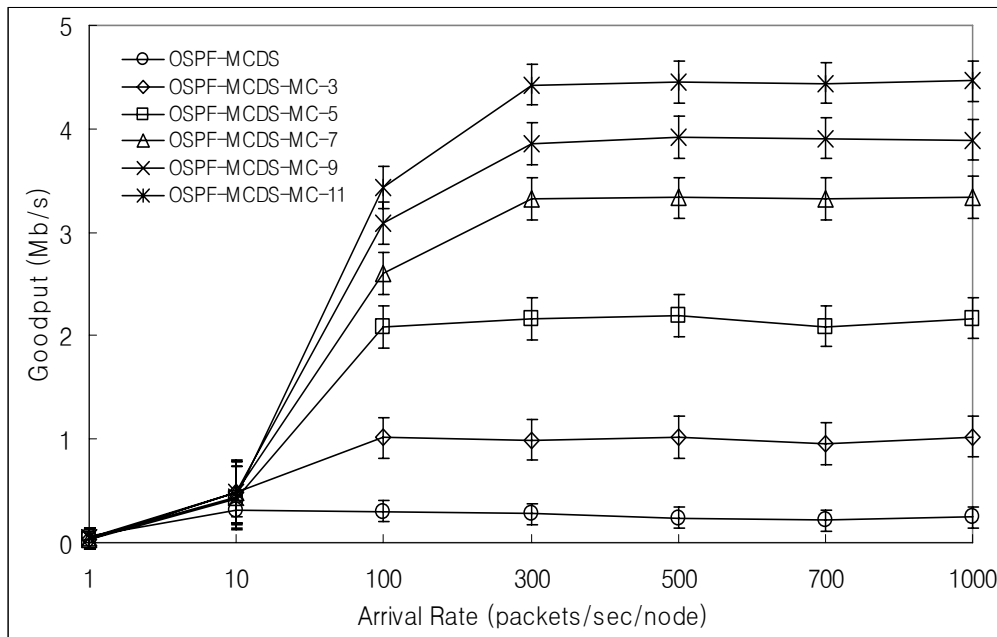
## 6.4.2 Results for Multiple-hop Networks

Similarly, we compare the goodput and control overhead for OSPF-MCDS-MC in multiple-hop networks. Figures 6.26 and 6.27 illustrate the goodput of OSPF-MCDS-MC for different packet arrival rates in stationary and mobile multiple-hop networks, respectively. The 95-percent confidence intervals are shown. As the network load increases, the goodput of OSPF-MCDS-MC increases with an increase in the number of channels. This indicates that the multi-channel routing scheme increases the network capacity even in a multiple-hop network. However, due to the multiple-hop path and node mobility, the maximum goodput for OSPF-MCDS-MC in both stationary and mobile configurations is lower than that for a single-hop network. As may be inferred from Figures 6.26 and 6.27, the smaller confidence interval indicates that the performance in the stationary network is more predictable than in the mobile network scenario.

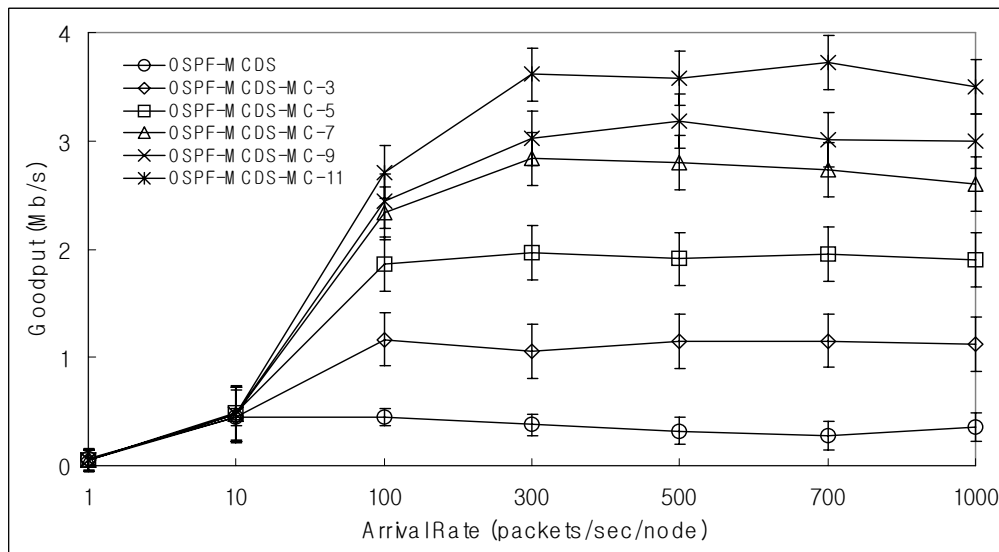
We analyze the number of routing messages for different numbers of nodes in stationary and mobile multiple-hop networks. The number of nodes ranges from 40 to 900 and any randomly selected destination should be reachable from the corresponding random source node. Figures 6.28 and 6.29 indicate that the number of routing messages in a multiple-hop network is higher than that of a single-hop network, as shown in Figure 6.22, due to the extra overhead of routing update messages caused by node mobility. In addition, the number of routing messages with the multi-channel system is slightly higher than that of single-channel system due to the channel update overhead in a multiple-hop network.

Finally, we examine the goodput with different numbers of channels and different numbers of nodes in stationary and mobile multiple-hop networks. Results are

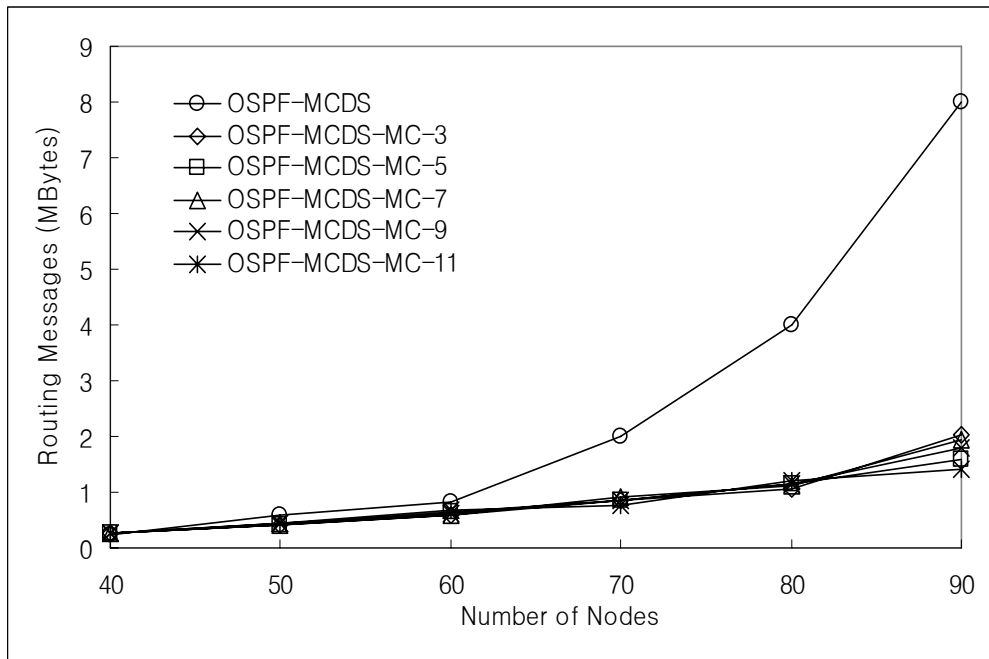
shown in Figures 6.30 and 6.31. As the number of nodes increases, the results indicate that goodput increases as the number of channels increases.



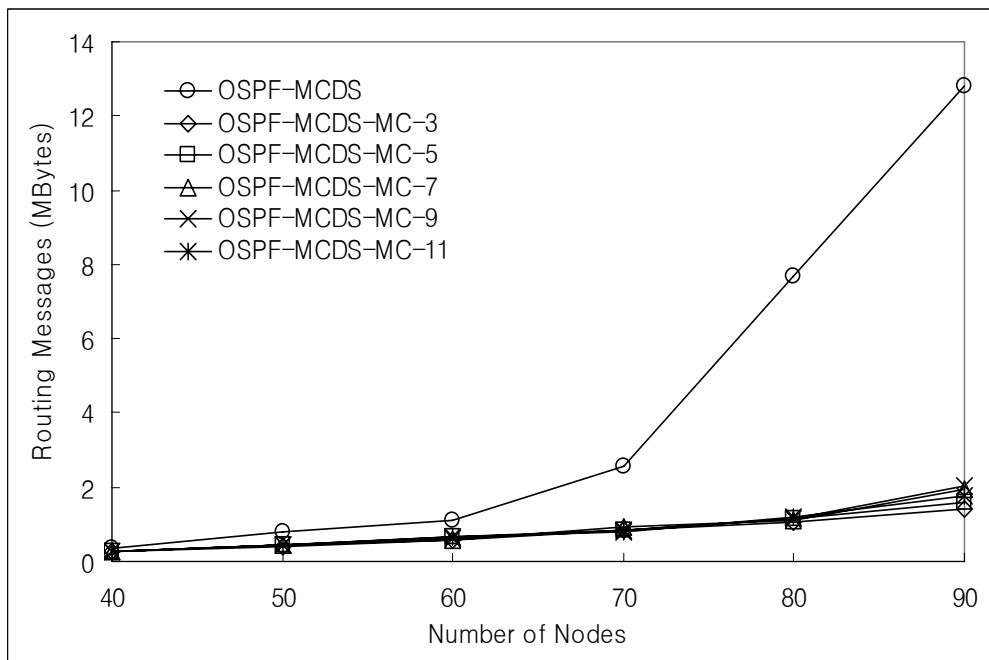
**Figure 6.26:** Goodput for stationary multiple-hop network for different packet arrival rates.



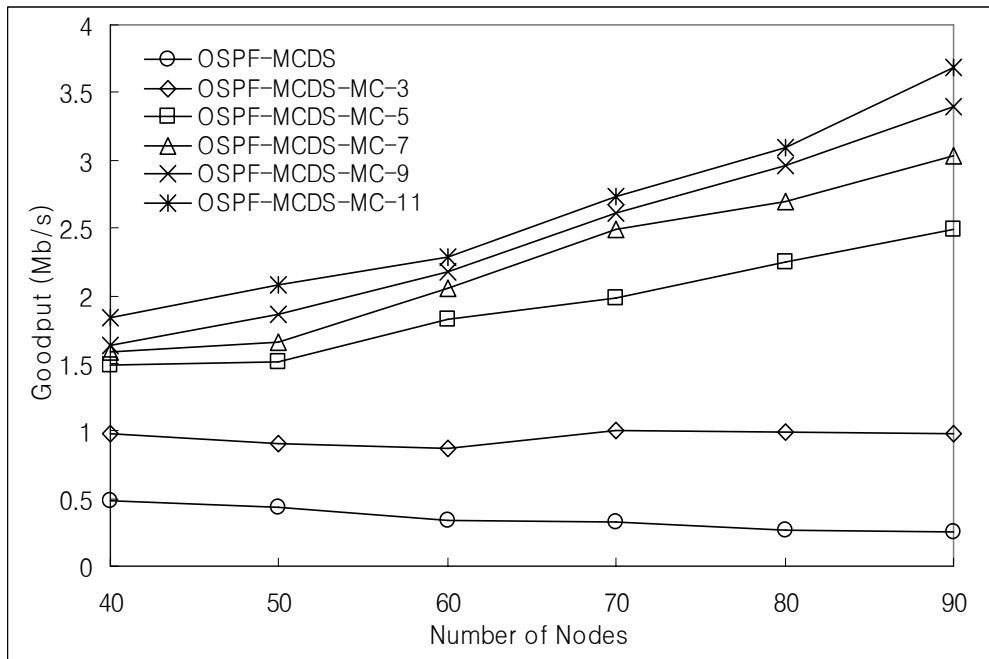
**Figure 6.27:** Goodput for mobile multiple-hop network for different packet arrival rates.



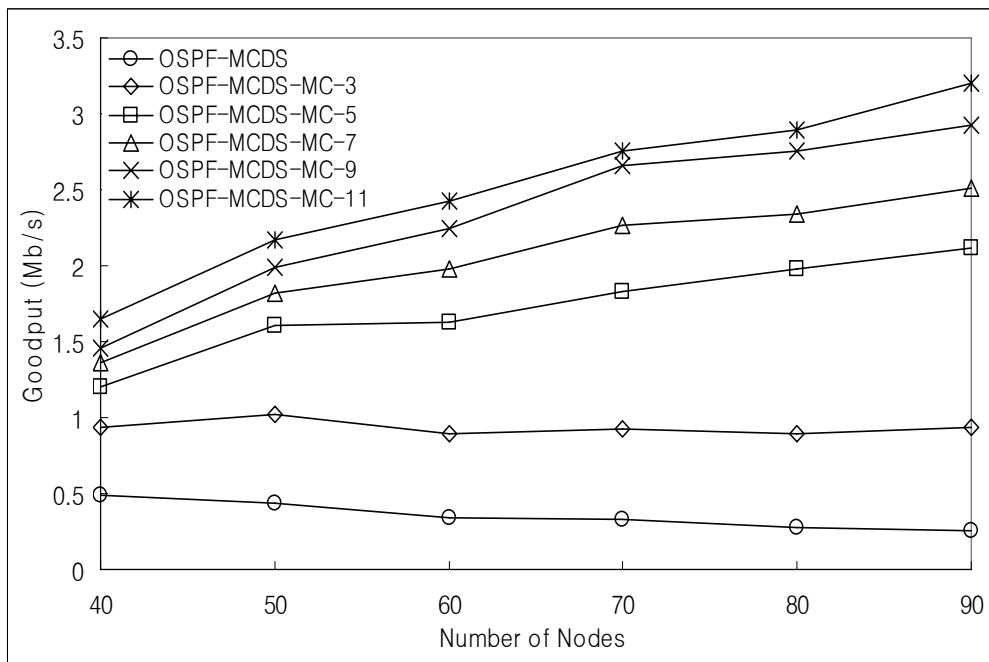
**Figure 6.28:** Number of routing messages for stationary multiple-hop network for varying numbers of nodes.



**Figure 6.29:** Number of routing messages for a mobile multiple-hop network for varying numbers of nodes.



**Figure 6.30:** Goodput for stationary multiple-hop network for varying numbers of nodes.



**Figure 6.31:** Goodput for mobile multiple-hop network for varying numbers of nodes.

## 6.5 Discussion

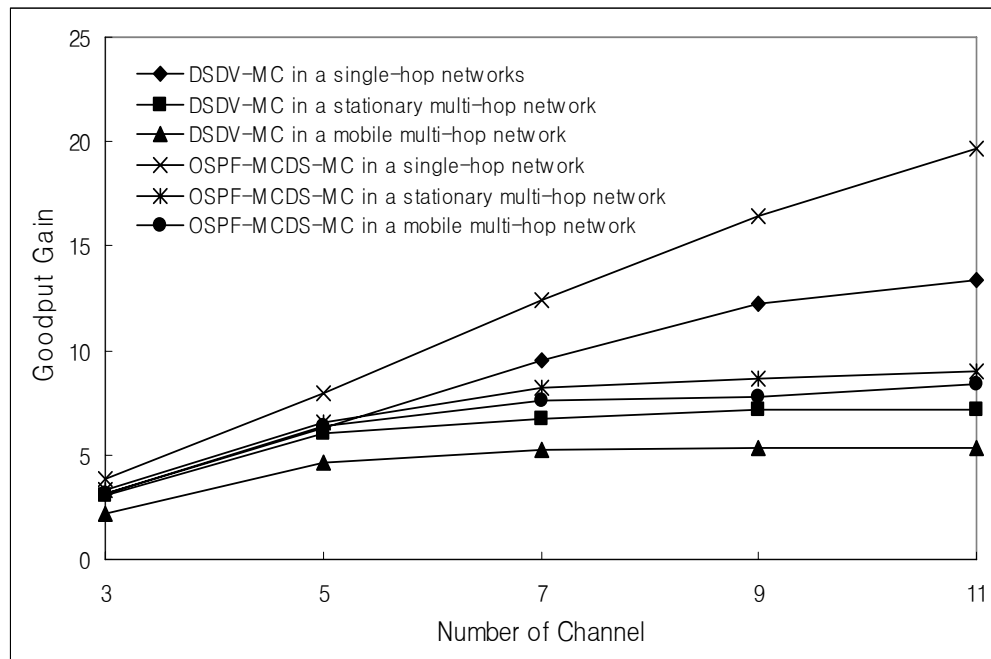
In this section, we compare simulation results for DSDV-MC and OSPF-MCDS-MC. We consider three metrics, goodput improvement, control overhead, and drop rate for varying numbers of channels.

Figure 6.32 shows the goodput gain of DSDV-MC and OSPF-MCDS-MC. OSPF-MCDS reports the link state changes immediately after the link changes are detected. This implies that OSPF-MCDS requires relatively higher control overhead than DSDV. As a result, as the number of channels increases, OSPF-MCDS-MC experiences more improvement in goodput than DSDV-MC since the control channel is separated from the data channel. The gain in goodput for single-hop networks is higher than for multiple-hop networks since the simulation experiments are performed in a highly congested network (60 nodes for single-hop and multiple-hop networks).

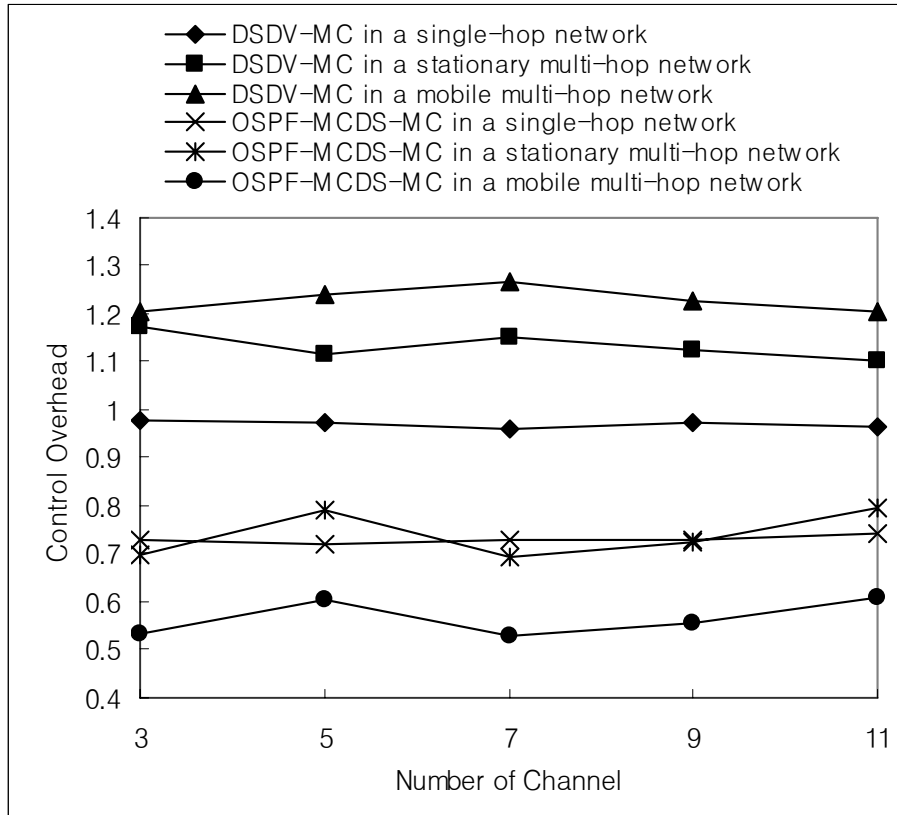
As indicated by Figure 6.33, OSPF-MCDS-MC requires less control overhead than single-channel OSPF-MCDS, while DSDV-MC requires more control messages than single-channel DSDV. Since OSPF-MCDS reports link state changes immediately after link changes are detected, it can have a small average hop count at the cost of control overhead [6]. However, in a congested network, the control messages cause collisions with the data messages. Thus, as the network congestion increases, the multi-channel scheme can improve the goodput and reduce the control overhead.

A comparison of the drop rate for the multi-channel schemes is presented in Figure 6.34. As the number of channels increases, the drop rate for DSDV-MC and OSPF-MCDS-MC decreases. The drop rate in single-hop networks decreases sharply com-

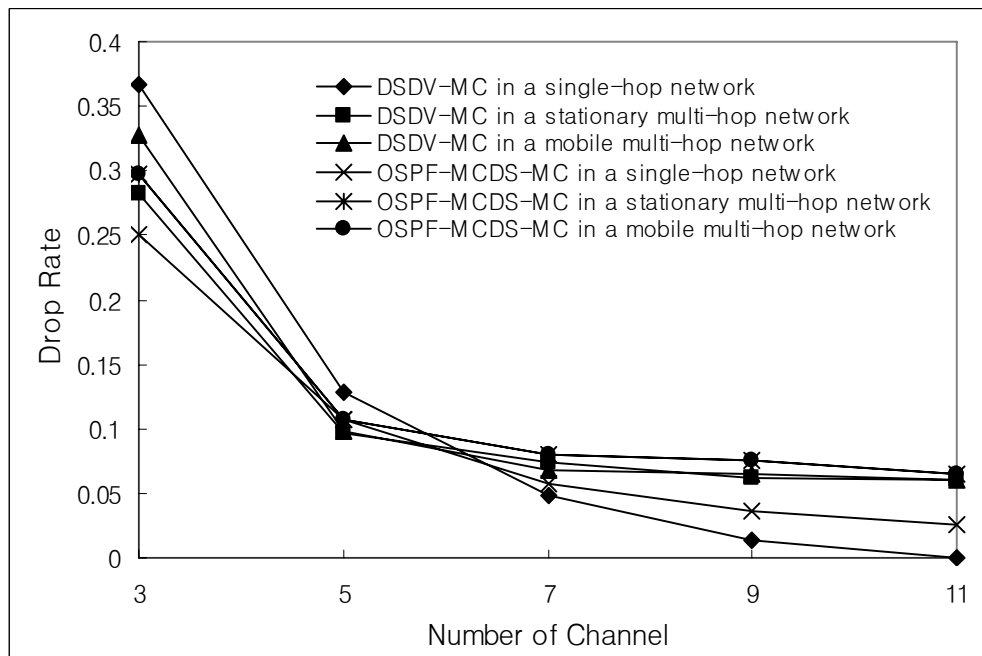
pared to the drop rate for multiple-hop networks since more packet loss occurs in a congested single-hop networks than in single-hop multi-channel networks due to the heavy load.



**Figure 6.32:** Goodput gain for varying numbers of channels.



**Figure 6.33:** Control overhead for varying numbers of channels.



**Figure 6.34:** Drop rate for varying numbers of channels.

## 6.6 Summary

In this chapter, we presented a new MobileNode object and a corresponding application program interface for simulation experiments using ns2. The new node object can access multiple channels concurrently and the new API provides the new node object with a way to assign different channels.

Through simulation experiments, we showed that DSDV-MC and OSPF-MCDS-MC successfully exploit multiple channels to improve network capacity for both single-hop and multiple-hop network scenarios. Simulation results indicate that DSDV-MC and OSPF-MCDS-MC increase the goodput for both single-hop and multiple-hop networks when compared to standard DSDV and OSPF-MCDS. The results also show that the packet drop rate decreases significantly when the number of channels increases since packets are distributed over multiple channels. The packet drop rate in a single-channel network increases rapidly as the offered load increases, especially in a multiple-hop network.

Results also suggest that the control channel did not become a performance bottleneck in DSDV-MC and OSPF-MCDS-MC since channel negotiation does not take place. In addition, we examined the number of routing packets, which reflects the routing overhead. Simulation results show that the number of routing packets in a network with DSDV-MC and OSPF-MCDS-MC was close the number in a single-channel network since nodes exchange routing packets through the common control channel.

Simulation results with the channel reallocation procedure were also presented. Simulations were performed for three network configurations: linear, single-hop, and

multiple-hop. We showed that the channel reallocation scheme can reallocate channels in a relatively fair manner after channels are unfairly allocated due to the channel convergence problem. The reference index,  $C_{Ref}$ , is configured manually for these simulations. The reference index should be changed automatically (adaptively) so that the channel reallocation can adapt to changes in the network topology or traffic characteristics.

Finally, we compared improvements in goodput, control overhead, and drop rate for OSPFMCDs-MC and DSDV-MC for varying numbers of channels. However, we did not provide a direct comparison between the two protocols due to a lack of proper characterization of different MANET protocols [9] and because this is beyond the scope of this research.

## **Chapter 7 Implementation and Experimental Results**

To demonstrate the multi-channel routing scheme, we extend the OLSR routing protocol to a multi-channel version, OLSR-MC and perform experimental validation. This section describes the implementation of the two key modules, the OLSR-MC Module (OMM) and the Virtual Interface Module (VIM). In addition, new HELLO and Channel Update (CU) messages are introduced. Architecturally, the Virtual Interface Module (VIM) is a loadable kernel driver and implements a virtual network adapter.

In this chapter, we present our architecture and implementation as background for understanding. Architectural implementation details are available in Section 7.1 and Section 7.2 for the OLSR-MC module and the VIM, respectively. Issues regarding implementation of multi-channel routing protocol are presented in Section 7.3. The experimental results are presented and discussed in Section 7.4.

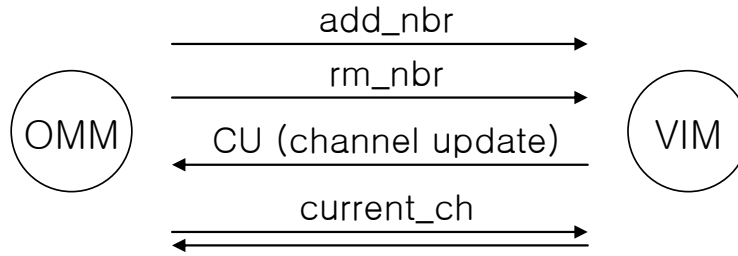
## 7.1 OLSR-MC Module

To realize OLSR-MC, we adapted the Naval Research Laboratory (NRL) OLSR implementation, `nrlolsrd`, which consists of NRL-developed code [47]. It is designed to run on Microsoft Windows, Unix, and Mac OS X. It supports both IP version 4 (IPv4) and IP version 6 (IPv6) and uses RFC 3626 packet formats with no Multiple Interface Declaration (MID) messages [47]. We made modifications, described below, to the Linux version of `nrlolsrd` for OLSR-MC.

### 7.1.1 Communication with the Virtual Interface Module

The OLSR-MC module communicates with the Virtual Interface Module to populate the neighbor table (NBR table) in the VIM. The neighboring nodes and channel information in the NBR table are referenced to decide the data channel according to the destination node or next-hop node of the packet to transmit.

The VIM is responsible for deciding when and how to switch the channel of the data interface according to the NBR table that is populated through communication with the OMM process. If VIM decides to switch the data channel, the Channel Update packet is broadcast to neighboring nodes before the VIM switches the data channel. Upon receiving the CU message from a neighboring node, a node updates channel information in the routing table. Since the VIM is loadable kernel module (LKM) [78] and is not able to create and transmit packets, it sends a signal to the OMM process to have OMM broadcast the CU message. Figure 7.1 and Table 7.1 illustrate the signaling and messages between OMM and the VIM.



**Figure 7.1:** Signaling between OMM and the VIM.

**Table 7-1:** Messages between the OMM and VIM.

Message	Direction	Action
add_nbr	OMM $\Rightarrow$ VIM	OMM provides neighbor information for the NBR table in the VIM.
rm_nbr	OMM $\Rightarrow$ VIM	OMM removes neighbors from the NBR table in the VIM.
channel update (CU)	VIM $\Rightarrow$ OMM	The VIM sends a signal to have OMM broadcast a CU message.
current channel query	OMM $\Rightarrow$ VIM and VIM $\Rightarrow$ OMM	The query from OMM to determine the current channel and the response with the current channel from the VIM. (This query follows a CU signal.)

### 7.1.2 New Format for HELLO and Channel Update Messages

A new HELLO message contains the channel index of each node as described in Section 4.5.1. Neighboring nodes update their neighbor (NBR) table based on this information. Given the link state information acquired through periodic message exchanges, as well as the interface configuration of the nodes, the routing table for each node can be computed. The interface in the routing table is configured to the VIM interface so that user data packets are forwarded to the virtual interface (see Figure. 4.6).

The Channel Update message is the new message intended to avoid the busy receiver problem in a multi-channel network, as described in Section 4.5.2. If a node switches its data channel without any notification to its neighbors, the neighboring nodes can have stale channel information in their routing tables. A node intending to change its channel broadcasts its new channel index using a CU message before it switches to the new channel (see Figure. 4.7).

### **7.1.3 Delayed Initial HELLO Message**

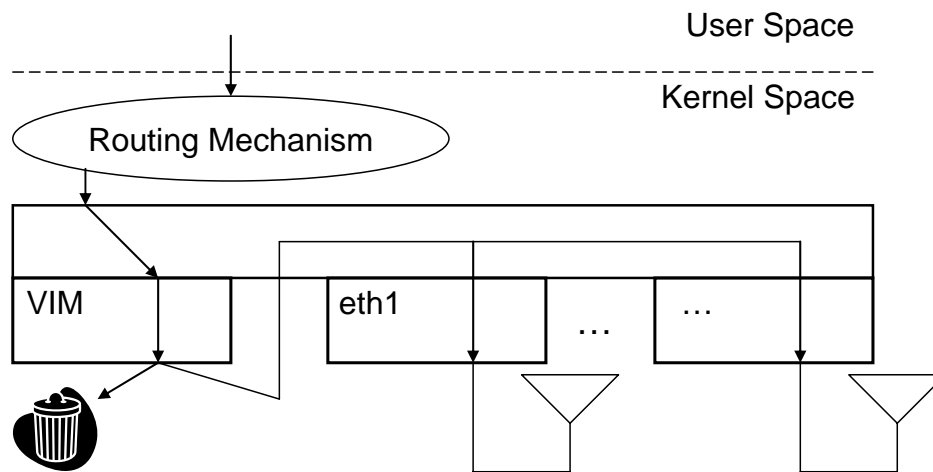
When a node joins a multi-channel network, it needs to decide the initial data channel. In our scheme, this initial channel is selected based on the channels used by neighboring nodes. The least used channel is selected. Since data channel information is piggy-backed with HELLO messages, a newly joined node defers sending its own HELLO message to receive HELLO messages from neighbors and select its initial data channel.

It has been verified that this delay does not impede routing in OLSR. When deciding routes, channel information from one-hop neighbors is sufficient since a transmitting node only needs to know the next-hop node's data channel to forward packets. However, when selecting an initial channel, a node needs the channel information for both one-hop and two-hop neighbors since interference from two-hop neighbors should be considered.

## **7.2 Virtual Interface Module**

The VIM is a logical network interface that does not provide any actual physical packet transmission. A virtual interface can be used to implement special-purpose processing

of data packets, while avoiding the complexity of changes to the kernel's network subsystem. It implements an interposition layer between Layer 2 (the link layer) and Layer 3 (the network layer). To higher-layer software, the virtual interface appears to be just another interface, albeit a virtual link. Figure 7.2 illustrates the data flow through virtual interface.



**Figure 7.2:** Data flow through the VIM.

This design has several significant advantages. First, higher-layer software runs unmodified over the multiple channels. No modifications to network stack were required. It increases the portability and transparency of the current protocol structure. Second, while we have currently implemented only the OLSR-MC protocol, the design, in principle, can support any ad-hoc routing protocol, such as DSR [11] or AODV [12].

### 7.2.1 Design Approach

To leverage the portability and transparency of the current protocol structure, our implementation adopts a virtual interface scheme. The virtual interface acts as the buffering

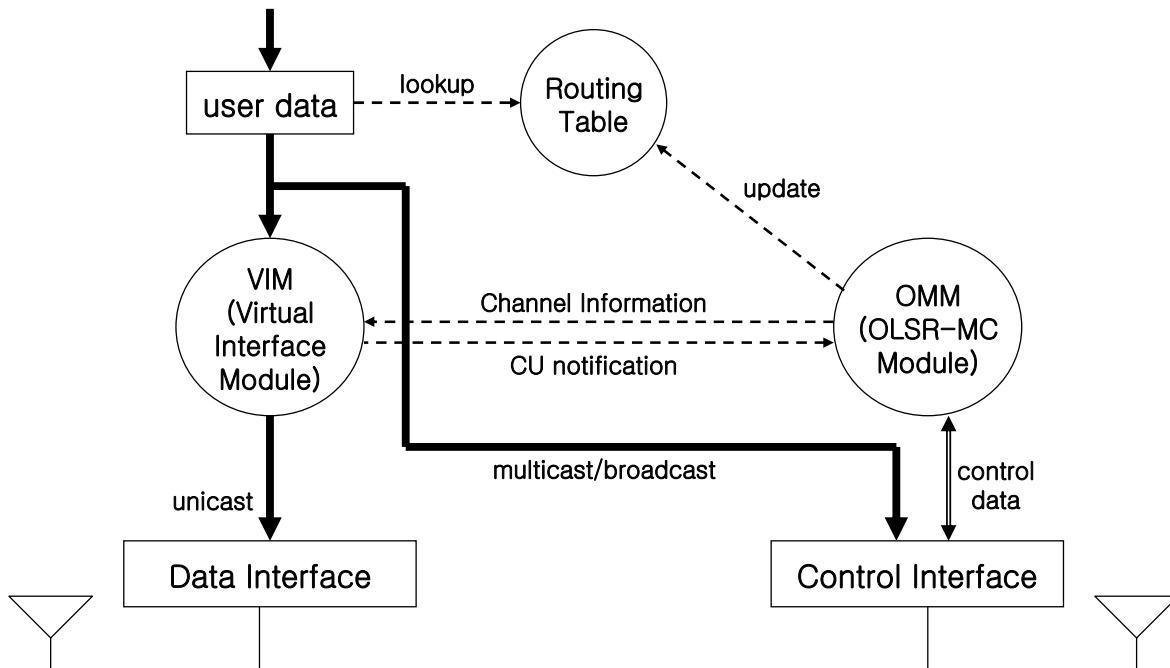
interface for outgoing packets and the end-point of communication with the OLSR-MC routing protocol. Outgoing packets initiate channel-related functions, such as channel lookup, channel switch, etc., in the VIM and are forwarded to the physical data interface to be transmitted.

The VIM determines the channel for the next-hop node, switches channels if needed, and forwards the packet to the data interface. Since the virtual channel is associated with the NIC for the data channel, the packets are not forwarded to the NIC for the control channel. Multicast and broadcast packets do not traverse the VIM since they are transmitted through the control channel. Figure 7.3 illustrates the data flow.

### **7.2.2 User Data Flow**

The following steps describe the flow of user data packets.

- 1) User data packets from the upper layer trigger the forwarding function to examine the routing table to determine the route (next-hop node) and the interface on which to transmit. OLSR-MC updates the entries in the routing table and modifies the interface entry by replacing the physical interface with the virtual interface so that packets are forwarded to the VIM.



**Figure 7.3:** Illustration of data flow.

- 2) When a user data packet arrives at the VIM, the VIM examines the NBR table in the VIM to determine the data channel of a destination node (or next-hop node). The VIM updates the NBR table as needed through communications with OMM.
- 3) If the data channel of the destination node or next-hop node is different from the current data channel of the transmitting node, the transmitting node's data channel is switched according to information in the NBR table. The VIM sends a channel update signal to OMM to trigger the broadcast of a CU message. If the destination's data channel is the same as the current data channel, packets are forwarded to the data interface without changing the channel.
- 4) When OMM receives a CU signal from the VIM, it acquires the new channel in-

dex from the VIM and broadcasts a CU message.

- 5) The VIM forwards the packet to the NIC for the data channel. Multicast and broadcast packets are forwarded to the control interface.

### **7.2.3 Neighbor Table**

The neighbor table in the VIM is populated through communication with OMM. The message types and signals between the VIM and OMM are presented in Section 7.1.1. The neighbor table in the VIM maintains a set of neighbor tuples based on the link tuples. Tuple information is updated according to changes in the Link Set by OMM. The neighbor tuple is the combination of one-hop neighbor, non-one-hop neighbor, and channel information. When a new link appears, that is, a new link tuple is created, the associated neighbor tuple must be created in the VIM if it does not already exist.

Each time a link changes, that is, each time the information in a link tuple is modified in OMM and a CU message is received, the neighbor table must be updated. Each time a link is deleted, that is, each time a link tuple is removed in OMM, the associated neighbor tuple in the VIM must be removed. These rules ensure that there is exactly one associated neighbor tuple in the neighbor table.

### **7.2.4 VIM Functions**

The VIM performs the following functions.

#### **7.2.4.1 Table Lookup and Communication with OLSR-MC**

The VIM looks up the destination of the packet to determine the data channel so that a

node can switch the channel according to the destination node or next-hop node. The VIM keeps the NBR table, which is updated through communication with OMM. The NBR table is a simple linked list with the IP address and channel information and can increase and decrease in size dynamically according to neighbor information from OMM. If events occur in OMM, such as detection of a new neighbor node, channel update, or neighbor deletion, OMM calls `ioctl` (the input/output control system call) provided by the VIM to update the neighbor table. Since the VIM is not able to transmit packets, it signals to OLSR-MC to broadcast a CU message.

#### **7.2.4.2 Packet Lookup and Channel Switch**

The VIM looks up the destination IP address of each packet and decides the channel index by referring to the neighbor table. If the channel of a destination node is different from the current channel, the VIM switches the data channel to transmit a packet to the destination node and notifies OMM of the channel switch. This channel update notification triggers OMM to acquire the new channel index from the VIM and to broadcast a CU message.

#### **7.2.4.3 Forwarding packets to the physical interface (data interface)**

After the channel index is determined, packets from the virtual interface module are forwarded to the physical interface for transmission.

### **7.3 Implementation Issues**

In this section, we discuss the issues we experienced during implementation of OLSR-

MC.

### **7.3.1 Multiple-hop Networks**

A MANET is a self-configuring network of mobile routers connected by wireless links, the union of which form an arbitrary topology. Nodes are free to move randomly and organize themselves arbitrarily. Thus, the network's wireless topology may change rapidly and unpredictably. Additionally, mobile nodes can create multiple-hop networks. If the final destination of packets is not one hop away, the IP address and the MAC address of packets are different. The MAC address specifies the next-hop node (or default gateway), and the IP address specifies the final destination node's interface. When a node receives a packet that is not destined to the node itself, it has to forward the packet, if possible.

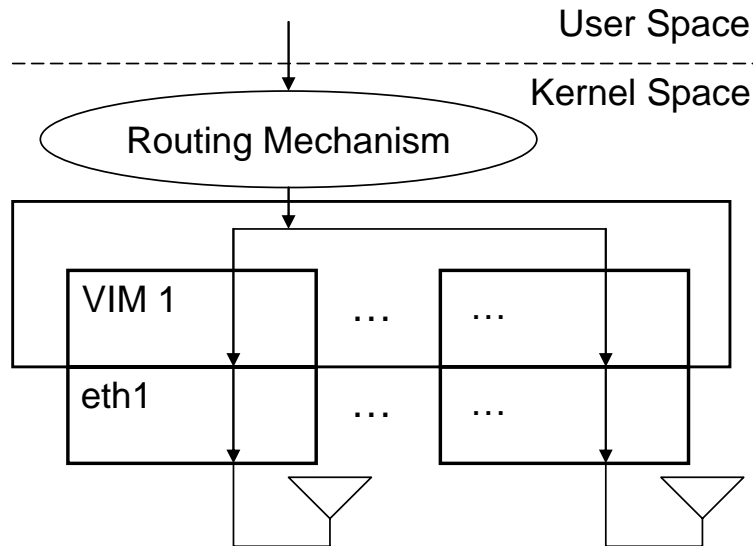
If the VIM checks only the destination IP address to determine the channel information and the final destination is not one hop away, the neighbor table should provide information for the next hop-node or default gateway. Therefore, the NBR table in the VIM includes channel information for a destination and a neighbor node (or gateway node).

### **7.3.2 Number of Virtual Interfaces**

As indicated above, the virtual interface scheme is adopted to leverage the portability and transparency of the current Linux protocol structure in our implementation. Based on the number of virtual interfaces, we can categorize different design approaches based on use of a single virtual interface or multiple virtual interfaces.

With a multiple virtual interface scheme, the number of virtual interfaces is the same as the number of NICs. Since each NIC in a node looks at a channel, the number of virtual interfaces is the same number of physical interfaces, as shown in Figure 7.4. In such multiple virtual interface scheme, each virtual channel handles packets for the each available channel. An advantage of this approach is reduction of the overhead to examine the neighbor table for channel information since the channel for the destination node (or next-hop node) is already known by virtue of knowing the virtual interface. However, the VIM must update the interface entry in the routing table according to dynamic changes in the channels used by other nodes.

Our design uses the single virtual interface approach. With the single virtual interface scheme, a single virtual interface handles all packets. All packets are forwarded to the virtual interface, and the channel switch is performed by the virtual interface module according to the destination of each packet. Therefore, the virtual interface performs channel selection, channel switching, and packet forwarding to the physical interface. The single virtual interface scheme does not require updating the routing table as frequently as with a multiple virtual interface scheme. The drawback of the single virtual interface scheme is the added overhead to look up the channel information in the neighbor table for every individual packet.



**Figure 7.4:** Multiple virtual interface scheme.

### 7.3.3 Address Resolution

“The term address resolution refers to the process of finding an address of a computer in a network. The address is "resolved" using a protocol in which a piece of information is sent by a client process executing on the local computer to a server process executing on a remote computer. The information received by the server allows the server to uniquely identify the network system for which the address was required and therefore to provide the required address. The address resolution procedure is completed when the client receives a response from the server containing the required address [68].”

The Address Resolution Protocol (ARP) is a protocol used in IPv4 to map IP network addresses to the hardware addresses used by a data link protocol. For IPv6, ICMPv6 neighbor discovery replaces ARP for resolving network addresses to link-level addresses. IPv6 neighbor discovery also handles changes in link-layer addresses, in-

bound load balancing, anycast addresses, and proxy advertisements. Nodes requesting the link-layer address of a target node multicast a neighbor solicitation message with the target address [68, 69].

An ARP miss occurs when a node cannot resolve the MAC address of a data interface, which normally occurs if the ARP request cannot be delivered to the destination node or next-hop node. An ARP miss can occur in the proposed multi-channel implementation if a sending node's data channel is different from the receiving node's data channel. Address resolution packets cannot be heard by the destination node or the next-hop node due to the lack of channel synchronization.

To resolve such ARP misses in our implementation, address resolution messages are exchanged over the control channel, which is reasonable since the address resolution messages are broadcast or multicast packets. Our implementation synchronizes the ARP caches for the control and data interfaces, which are separate caches. The ARP cache of the data interface is populated by the ARP cache of the control interface, which requires modification of the ARP request mechanism since the ARP request should be transmitted through the control interface. Reception of address resolution messages refreshes the ARP cache of the control interface as well as data interface.

### **7.3.4 Routing Table Manipulation**

Each node in a network maintains a routing table that directs it to route data destined for other nodes. The routing table is based on information contained in the local link information base and the topology set. Therefore, if any of these sets are changed, the routing table is recalculated to update the route information for each destination in the

network. The route entries are recorded in the routing table using the format given in Figure 7.5.

Destination	Gateway	Metric	Iface
-------------	---------	--------	-------

**Figure 7.5:** Format of routing table entries

Each entry in the table consists of the destination, gateway, metric, and local interface address. Such an entry specifies that the node identified by “destination address” is estimated to be “metric” hops away from the local node, that the symmetric neighbor node with interface address “gateway” is the next-hop node in the route to “destination,” and that this symmetric neighbor node is reachable through the local interface with the address “Iface.”

In our implementation, the VIM interface replaces the physical interface as the “Iface” entry when the routing table is recalculated to update route entries so that the symmetric neighbor node can be reached through the VIM interface. As the VIM interface forwards packets to the symmetric neighbor node, it performs the functions presented in Section 7.2.4.

Another issue regarding the routing table is how to handle Host and Network Association (HNA) messages. An HNA message is issued periodically to provide connectivity from an OLSR-enabled interface (or interfaces) to a non-OLSR-enabled interface (or interfaces). A node may be equipped with multiple interfaces, some of which may not participate in the OLSR-routed network. These non OLSR interfaces may be point-to-point connections to other singular hosts or may connect to separate networks. A

node should be able to inject external route information into the OLSR network. An HNA message contains sufficient information for the recipients to construct appropriate routing table entries. Upon receiving an HNA message, the VIM interface is configured as an appropriate local interface in the routing table [7].

## **7.4 Experimental Results for OLSR-MC**

We performed experiments with OLSR and OLSR-MC implemented on Redhat Linux [70] using Iperf [71] to measure throughput. Our test bed uses the Xircom CreditCard IEEE 80211b NIC with the Orinoco device driver for both OLSR and OLSR-MC. Each system is equipped with two PC Card NICs to access the control and data channel simultaneously for the multi-channel scheme. Since IEEE 802.11b, which has three non-overlapping channels, is used, two data channels and one control channel are used for experiments.

The bit rate for each channel is set to 2 Mbps at the MAC layer. This allows comparison with ns2 results. Each source node generates and transmits constant bit rate (CBR) traffic. We ran each transmission for 100 seconds and each data point in the results is the average of 30 replications. Unless otherwise specified, the packet size is 1470 bytes and the arrival rate from each node is 2 Mbps. Half of the nodes were data sources and the other half were data destinations.

Figure 7.6 shows the maximum throughput for each node for different arrival rates with two and three connections with OLSR and OLSR-MC. We use the maximum throughput as a performance metric for experimental results. The maximum throughput is the amount of data received in a specific amount of time as measured by the Iperf ap-

plication between the sender-receiver pair. As the number of nodes increases (the number of connections increases), the maximum throughput decreases in both the single-channel and multi-channel environment due to channel saturation. The maximum throughput in the multi-channel network with OLSR-MC is higher than that in the single-channel network using OLSR since the network saturation point increases as the number of channels increases. So, network capacity increases as the number of channels increases, at least to a point.

Figure 7.7 shows the maximum throughput for different packet sizes with two and three connections with OLSR and OLSR-MC. The figure also includes the maximum theoretical throughput as a reference. We vary the packet size from 100 to 1400 bytes. The maximum throughput is the average of the throughput as measured by Iperf at the receivers. Generally, the throughput is higher when the packet size is larger mainly because there is less control overhead. With larger packets, a larger amount of data is sent for each RTS/CTS exchange and, thus, contention for the channel occurs less frequently.

When the packet size is small, the control channel can become a bottleneck if a channel negotiation scheme is used [25]. However, since OLSR-MC does not require channel negotiation, the common control channel does not become a bottleneck. Therefore, the throughput of OLSR-MC does not increase sharply as the packet size increases.

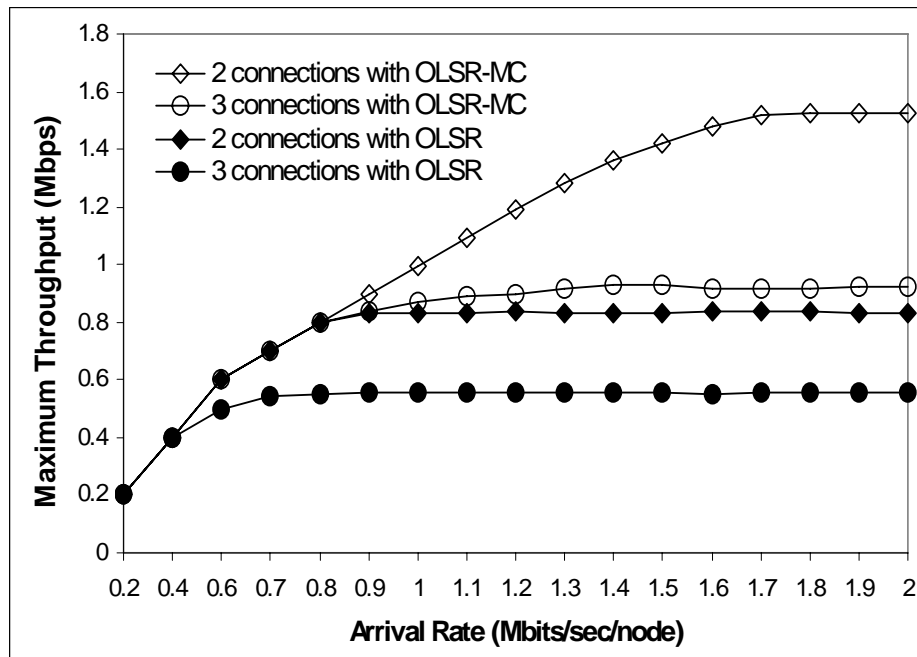
The throughput of the multi-channel system with one connection (MC 1 connections) is slightly lower than that of the single-channel system with one connection (SC 1 connection) due to the overhead of having multiple interfaces in the system. Likewise, the throughput of the multiple-channel system with two connections (MC 2 connections) is lower than the multi-channel system with one connection (MC 1 connection).

The “Reference” curve in Figure 7.8 is the theoretical maximum throughput, measured at the transport layer at the receiver, which can be achieved by IEEE 802.11b. To simplify the calculation of the theoretical maximum throughput, we assume that there is only one sender and receiver pair in the IEEE 802.11 MAC layer’s Distributed Coordination Function (DCF) mode with no interfering stations nearby. We also assume that the channel is error-free and we neglect propagation delays. IEEE 802.11 PHY characteristics and associated calculations are presented in Appendix C. Due to the physical and MAC layer overhead from the header, checksum, and back-off process, the throughput of one connection for both single-channel and multi-channel schemes is lower than the theoretical maximum throughput.

Although OLSR-MC requires additional overhead to advertise channel information along with routing information, the number of routing packets in the network is close to that for the single-channel case. In a single-channel network, as used with standard OLSR, the drop rate increases sharply as the network becomes congested and more routing messages are likely to be dropped since routing messages and data packets share a single channel. At the expense of an extra channel for control messages, OLSR-MC provides relatively lower congestion than the single-channel network.

In this experiment, multiple destination nodes use the different channels. Sending nodes transmit packets to the nodes in the two data channels with intervals of 1, 3 and 5 s. Therefore, in the case of a 1-second interval, each sending node switches its data channel and broadcasts a CU message with an interval of 1 second. As seen in Figure 7.8, there is no overhead in the situation where there is no channel switching. The overhead of advertising a channel update with routing messages in OLSR-MC increases slightly as

the interval decreases. However, the number of messages is still close to the number of the single-channel case.



**Figure 7.6:** Maximum throughput for varying arrival rate.

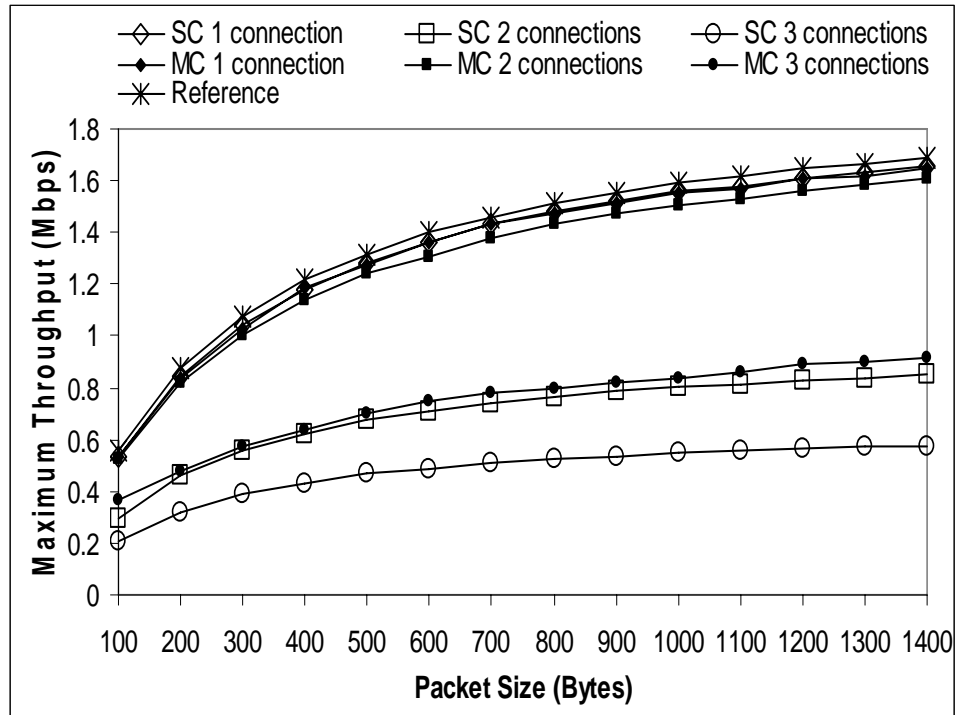


Figure 7.7: Throughput with varying packet size.

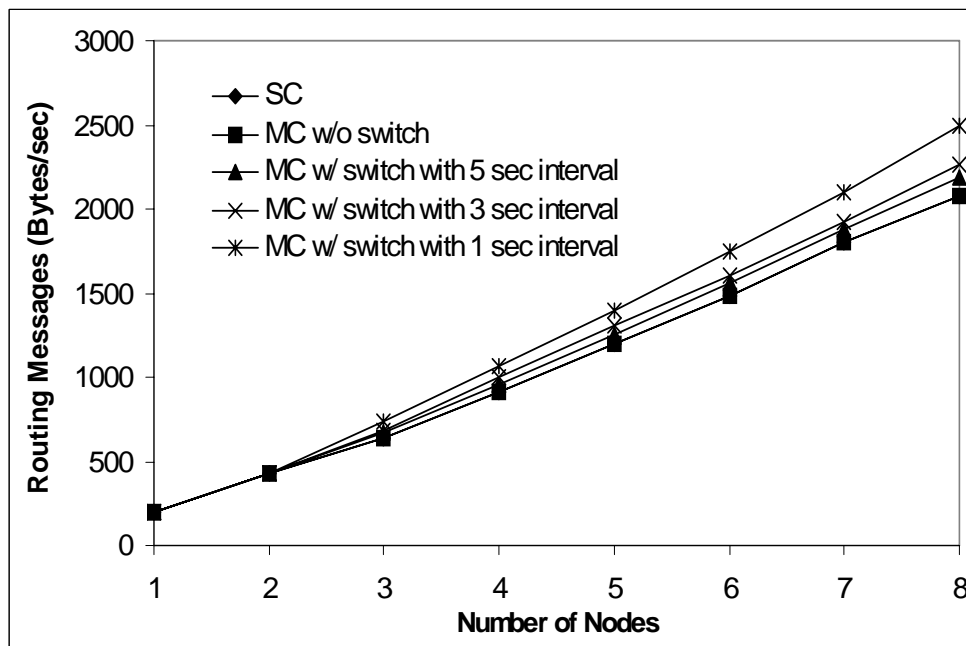


Figure 7.8: Data rate for routing messages for different numbers of nodes.

## 7.5 Summary

In this section, we presented our implementation of OLSR-MC and performed experimental validation. For the OLSR-MC implementation, we modified the NRL version of OLSR, `nrlolsrd`. We proposed a new HELLO message format to include the channel index and a new Channel Update message to avoid the busy receiver problem in a multi-channel network. For channel initialization, we introduce a scheme to delay transmission of the initial HELLO message.

We also proposed the use of the logical network interface, VIM, to carry out the channel-related functions while maintaining portability and transparency. The VIM decides the data channel according to the destination node or the next-hop node for a packet. The VIM, also, communicates with OLSR-MC to populate the neighbor table, forwards packets to the physical data interface, and switches its data channel if needed.

The experimental results show that the network saturation point increases as the number of channels increase, i.e., network capacity increases as the number of channels increases. We also show that the number of routing messages for the multi-channel scheme is close to the number of routing messages for the single-channel case, although OLSR-MC requires additional overhead to advertise channel information as well as routing information.

## Chapter 8 Conclusions and Future Work

In this chapter, we summarize our research, highlight contributions, and discuss potential future research.

### 8.1 Summary

We presented the design, implementation, and analysis of a multi-channel routing protocol that utilizes multiple channels in mobile ad-hoc networks such that multiple communications can occur simultaneously to improve network capacity. The proposed scheme requires only minor changes to a proactive routing protocol and no modifications to the current IEEE 802.11 MAC protocol, while most other schemes for multi-channel operation require modification of the MAC protocol [3, 19, 21, 22, 23, 24, 25, 27, 28, 29, 30, 31, 33, 34].

The proposed proactive routing protocol provides not only a routing mechanism, but also a method to gather channel information to enable efficient channel assignment. To share routing advertisements among neighboring nodes, our scheme divides the network layer into control and data planes. This scheme decreases the potential inefficiency of a proactive routing protocol that results from the need for periodic transmission

of routing updates by avoiding competition with unicast user data. Advertisements of routing information are transmitted through the control channel and unicast user packets (packets from an upper layer) are sent using the data channel. Broadcast and multicast user packets are sent using the control channel.

To demonstrate integration with existing proactive routing protocols, we have designed extensions of DSDV and OSPF-MCDS, called DSDV-MC and OSPF-MCDS-MC, respectively. We also performed simulation experiments with DSDV-MC and OSPF-MCDS-MC. We proposed a new HELLO message format to include the channel index and a new Channel Update message to avoid the busy receiver problem in a multi-channel network. For channel initialization, we introduce a scheme to delay transmission of the initial HELLO message.

For simulation studies, we introduced a new MobileNode model with a corresponding application program interface for ns2. The new node model can access multiple channels concurrently and the new API provides the new node model with a way to assign different channels.

Simulation results showed that DSDV-MC and OSPF-MCDS-MC successfully exploit multiple channels to improve network capacity. Results imply that the packet drop rate decreases significantly when the number of channels increases since packets are distributed to more channels. Results also show that the control channel does not become a bottleneck in DSDV-MC and OSPF-MCDS-MC since the proposed scheme does not require per-packet channel negotiation using the control channel. In addition, the number of routing packets in a network with DSDV-MC and OSPF-MCDS-MC is close to the number for routing packets for a single-channel system since routing packets are ex-

changed using the common control channel. We also compared goodput, control overhead, and drop rate for OSPF-MCDS-MC and DSDV-MC for a varying number of channels.

In addition to simulation, we implemented OSPF-MCDS-MC and conducted test bed experiments to validate simulation results and to examine practical issues in the use of the multi-channel scheme. For the implementation, we modified the NRL version of OLSR, `nrlolsrd`. We propose the use of the logical network interface, VIM, to perform channel-related functions, while maintaining portability and transparency. The VIM selects the data channel according to the destination node or the next-hop node of a packet. The VIM, also, communicates with OLSR-MC to populate the neighbor table, forwards the packets to the physical data interface, and switches its data channel if needed.

The experimental results show that the network saturation point increases as the number of channel increases, i.e., the scheme can provide an increase in network capacity as the number of channels increases. We also show that the number of routing messages with the multi-channel scheme is close to the number of such messages for the single-channel scheme, although OLSR-MC requires additional overhead to advertise channel information as well as routing information.

The ultimate goal is to achieve  $N$  times the goodput compared to a single-channel system when  $N$  channels are available. Since the control channel does not become a bottleneck and the number of control (routing) messages does not increase significantly, our proposed scheme does come reasonably close to achieving this goal for a modest number of channels. Efficiency in channel utilization degrades as the number of chan-

nels increases due to traffic characteristics and since, in our study, we use a single transceiver per node for data.

Along with a proactive routing protocol for multi-channel networks, we presented the channel distribution index, a new metric to explore fairness in multi-channel wireless ad-hoc networks. Even though available channels are fairly distributed initially, they can become unfairly distributed due to channel assignment characteristics such as the channel convergence problem. If channels are distributed unfairly, the proposed multi-channel routing scheme is not able to exploit the multiple channels and, as a result, the network capacity cannot be utilized effectively.

The proposed metric, the Channel Distribution Index (CDI), indicates the fairness of channel distribution from the perspective of an individual node (the local CDI) and the network (the global CDI). The index is calculated based on channel information in a routing table. The CDI indicates the dynamic channel distribution among neighboring nodes. The purpose of this metric is to measure the balance of the channel distribution. Fairness in channel distribution, which results in a CDI value close to 1, implies that all channels are used equally. As a result, network capacity increases because channel resources are used efficiently.

Simulation results show that the CDI indicates the fairness of channel distribution in multi-channel networks. The results also suggest that if channels are distributed unfairly, as indicated by a CDI value close to 0, the multiple channels cannot be effectively exploited and the goodput decreases.

While most prior work focuses on the channel assignment problem and multiple access control protocols for multi-channel operation, our study provides a method to

evaluate the effectiveness of channel assignment and distribution among neighboring nodes. Depending on the network topology and traffic pattern, only some of the available channels might be used, leading to unfairness. This unfairness can cause certain channels to be congested while other channels are idle. Unfairness can degrade network throughput. Thus, nodes should detect and react to such unfairness to ensure effective use of available capacity. The proposed CDI provides a means to evaluate unfairness.

The analysis of continuity and bounds of the CDI were discussed to show that the proposed definition has desirable properties. A channel reallocation scheme was proposed based on the CDI with the objective of reducing the impact of the channel convergence problem.

Along with the research on channel distribution and fairness, we illustrated the channel convergence problem using a wireless sensor network scenario and proposed a channel reallocation scheme. The channel reallocation scheme enables nodes to adapt to changes in the channel distribution in the network due to network topology and traffic characteristics.

## **8.2 Contributions**

The example proactive protocols based on our multi-channel routing scheme, DSDV-MC, OSPF-MCDS-MC, and OLSR-MC indicate that it is possible to provide not only routing, but also channel information to assign channels efficiently without channel negotiation, channel scanning, and synchronization. It also verifies that utilization of multiple channels in ad-hoc networks provides the benefits of increasing network capacity and increas-

ing efficiency by reducing the probability of collisions.

Multi-channel schemes are becoming more attractive as the cost of transceivers decreases and the capacity requirements for potential ad-hoc network applications increase. Most past research on multi-channel schemes for ad-hoc networks are performed from the MAC layer's perspective. Our research provides a different approach to utilize multiple channels. We believe that future research based on our work can be valuable to the MANET research community. The proposed routing protocol can also provide insight for future cross-layer design research [44, 72, 73, 74] in a multi-channel environment.

To our knowledge, the study of the fairness of channel distribution and utilization has not been performed before. As the cost of transceivers drops due to hardware technology improvements and network capacity needs increase, the utilization of available multiple channels will be an effective approach to improve the throughput of wireless networks. More importantly, our research on the channel distribution and utilization metrics can aid the study of multi-channel schemes. Our proposed new metrics for multi-channel environments can be used to evaluate a multi-channel scheme in terms of the fairness of channel distribution and utilization. In addition, the metrics can provide guidance for one to choose proper multi-channel scheme.

We also believe that the new node model in ns2 introduced to simulate a node with multiple interfaces and the corresponding API can be used for further research on multi-channel schemes. Implementation issues presented for multi-channel extension implementation can be applied and adapted to further research on multi-channel routing protocols. Since we designed and implemented the VIM to provide portability and transpar-

ency of the current protocol structure, it can be combined with any typical proactive routing protocol.

### 8.3 Future Directions

Utilization of multiple channels in multiple-hop ad-hoc networks and mesh networks has received increasing attention from the research community in recent years. There are many active research projects concerned with multi-channel and channel assignment in MANETs and mesh networks. This section focuses on promising future research directions based on our research.

In our simulations, we assumed that the channel switching overhead is negligible. However, we should not ignore the channel switching overhead if it happens frequently. This situation is described as the “frequent channel switching” problem [20, 26]. Further study of methods to reduce the frequency of channel switching is also a promising research direction. Such a study might aid in the design of MANET routing protocols that conserve energy, improve network lifetime, and improve overall performance.

The current implementation of the channel reallocation scheme requires that the reference index and time interval be configured manually. However, based on network topology and traffic characteristics, the channel distribution can be changed dynamically. Consequently, the reference index should adjust dynamically to these changes. An adaptive reference index is proposed to support dynamic changes of the CDI. Nodes can calculate the CDI and adapt the reference index for changes of the CDI. For the adaptive reference index, we will analyze the relationship between traffic characteristics and the CDI in depth so that the reference index can be adjusted appropriately according

to the network environment.

Along with further investigation of the proposed channel distribution index, more investigation of the channel utilization index is, also, a potential future research direction. The channel utilization index (CUI) indicates the fairness of channel utilization from a network perspective. The purpose of this metric is to indicate the balance of channel utilization. Fair channel utilization implies that all channels are exploited equally, which leads to an increase in network capacity.

The fairness index can be derived from the fairness index of Jain, Chiu, and Hawe [61] and Chiu and Jain [62] and is computed as follows.

$$CUI = \frac{(\sum_{i=1}^n y_i)^2}{n(\sum_{i=1}^n y_i^2)} \quad (2)$$

Here,  $n$  is the number of channels available in the network and  $y_i$  is the number of messages transmitted successfully in the  $i$ th channel in the network. CUI ranges from 0 to 1 and is maximized when all channels are fairly utilized in network.

Cross-layer design is another promising research direction. For CUI estimation, channel usage information in lower layer should be needed for the dynamic wireless environment. In addition, since proactive routing protocols can provide full topology information, it is possible to use this information to tune the parameters of lower and/or higher layer protocols.

# Appendix A

## List of Acronyms

ACK	Acknowledgment
AODV	Ad-hoc On-demand Distance Vector
AP	Access Point
API	Application Program Interface
ARP	Address Resolution Protocol
ATIM	Announcement (Ad-hoc) Traffic Indication Message
AWINN	Advanced Wireless Integrated Navy Network
BAR	Bandwidth-Aware Routing
BSS	Basic Service Set
C2M	Control Channel-based MAC
CA	Channel Assignment
CAM	Channel Access Method
CBR	Constant Bit Rate
CCA	Clear Channel Assessment
CCH	Control Channel
CDI	Channel Distribution Index
CDMA	Code Division Multiple Access
CFI	Contention-Free Interval
CRC	Cyclic Redundancy Check

CRI	Contention Reservation Interval
CS	Carrier Sensing
CSA	Channel Scheduling Algorithm
CSMA/CA	Carrier Sense Multiple Access with Collision Avoidance
CTS	Clear-to-Send
CU	Channel Update
CUI	Channel Utilization Index
DCA	Dynamic Channel Assignment
DCF	Distributed Coordination Function
DCH	Data Channel
DIFS	Distributed Inter-Frame Space
DPC	Dynamic Private Channel
DSDV-MC	Destination-Sequenced Distance-Vector for Multi-Channel
DSR	Dynamic Source Routing
DUCHA	Dual Channel MAC
ESS	Extended Service Set
ETT/WCETT	Expected Transmission Time/Weighted Cumulative ETT
FCA	Fixed Channel Allocation
FI	Fairness Index
HCA	Hybrid Channel Allocation
IBSS	Independent BSS
IEEE	Institute of Electrical and Electronics Engineers
INSTC	Interference Survival Topology Control
IP	Internet Protocol
IWMN	Infrastructure Mesh Networks

LAN	Local Area Network
LDD	Link Database Description
LKM	Loadable Kernel Module
LSD	Link State Description
MAC	Medium Access Control
MAP	Multi-channel Access Protocol
MANET	Mobile Ad-Hoc Network
MC	Multi-Channel
MID	Multiple Interface Declaration
MR-LQSR	Multi-Radio Link-Quality Source Routing
MMAC	Multi-channel MAC
MPR	Multipoint Relay
MUP	Multi-radio Unification Protocol
NAV	Network Allocation Vector
NAVCIITI	Navy Collaborative Integrated Information Technology Initiative
NBR	Neighbor
NCA	Negotiation-based Channel Assignment
NCTS	Negative CTS
NIC	Network Interface Card
NPDU	Network Protocol Data Unit
NRL	Naval Research Laboratory
NRLOLSRD	Naval Research Laboratory Optimized Link State Routing Daemon
NS	Neighbor Solicitation
OMM	OLSR-MC Module
OLSR	Optimized Link State Routing

OLSR-MC	Optimized Link State Routing for Multi-Channel
OSPF-MCDS-MC	Open Shortest Path First with Minimum Connected Dominating Sets for Multi-Channel
PCAM	Primary Channel Assignment-based MAC
PCA	Pairwise Code Assignment
PCF	Point Coordination Function
PHY	Physical
PLCP	Physical Layer Convergence Protocol
PRN	Packet Radio Network
QOS	Quality of Service
RCA	Receiver-based Channel Assignment
RFC	Request for Comment
RMR	Routing Message Ratio
RRTS	Reply to RTS
RTS	Request-to-Send
SHARP	Sharp Hybrid Adaptive Routing Protocol
SIFS	Short Inter-Frame Space
SSCH	Slotted Seeded Channel Hopping
SSID	Service Set Identifier
TBRPF	Topology Broadcast Based on Reverse-Path Forwarding
TCA	Transmitter-based Channel Assignment
TCP	Transport Control Protocol
VLAN	Virtual LAN
VIM	Virtual Interface Module
WECA	Wireless Ethernet Compatibility Alliance

# Appendix B

## VIM implementation

### Loadable Kernel Module

“The most basic way to change code in a Linux kernel is to add one or more source files to the kernel source tree and recompile the kernel. Another way to add code to the Linux kernel is to add code while the kernel is running. A chunk of code added in this way is called a loadable kernel module (LKM). These modules can do many things, but they typically for one of three types of functions: 1) device drivers; 2) filesystem drivers; and 3) system calls. The kernel isolates certain functions, including these, especially well so they do not have to be intricately “wired” into the rest of the kernel. A LKM, when loaded, is part of the kernel.” [78]

### Loadable Kernel Module Commands

The programs we need to load and unload and otherwise work with LKMs are in the package modutils. This LKM package contains the following programs to use LKMs. [78]

insmod: Insert an LKM into the Kernel

rmmod: Remove an LKM from the Kernel

depmod: Determine interdependencies between LKMs

kernel: Kernel daemon program

ksyms: Display symbols that are exported by the kernel for use by new LKMs

lsmod: List currently loaded LKMs

modinfo: Display contents of modinfo section in an LKM object file

modprobe: Insert or remove an LKM or set of LKMs intelligently. For example, if you must load A before loading B, modprobe will automatically load A when you tell it to load B

# Appendix C

## Calculation of Optimal Data Rate in 802.11b

The time to transmit an IEEE 802.11b data frame with an  $L$ -byte payload at  $m$  Mbps PHY rate is given by:

$$T_{data}^m(L) = t_{PLCP\ Pr\ eamble} + t_{PLCP\ Header} + \frac{8 * (28 + L)}{m * 1000000}$$

The time to transmit an ACK frame at  $n$  Mbps PHY rate is given by:

$$T_{ack}^n(L) = t_{PLCP\ Pr\ eamble} + t_{PLCP\ Header} + \frac{8 * 14}{n * 1000000}$$

With these assumptions, the throughput (in bps) of the system, when the data frames are transmitted at  $m$  Mbps and the ACK frames are transmitted at  $n$  Mbps, is given by:

$$T(m, n) = \frac{8 * L}{aDIFS\ Time + \overline{T_{bk}} + T_{data}^m(L) + aSIFS\ Time + T_{ack}^n}$$

For the above, the average backoff time is given by:

$$\overline{T_{bk}} = \frac{CW\ min}{2} \times aSlot\ Time$$

The values given in Table C-1 for IEEE 802.11b and transmission rates of  $m = 2$  Mbps for data and  $n = 2$  Mbps for the ACK are used for the reference calculation [75].

Table C-1: IEEE 802. 11b PHY Characteristics

Parameters	Value	Comments
<i>aSlotTime</i>	20 usec	Slot time
<i>aDIFSTime</i>	50 usec	DIFS time
<i>aSIFSTime</i>	10 usec	SIFS time
<i>aCWmin</i>	31	Minimum contention window size in Units of aSlotTime
<i>TPLCPPreamble</i>	144 usec	PLCP preamble duration
<i>TPLCPHeader</i>	48 usec	PLCP header duration

# Bibliography

- [1] IEEE Standard 802.11, “Wireless LAN Medium Access Control (MAC) and Physical Layer (PHY) Specification,” August 1999.
- [2] F. A. Tobagi and L. Kleinrock, “Packet Switching in Radio Channels: Part II – The Hidden Terminal Problem in Carrier Sense Multiple-access Modes and the Busy Tone Solution,” in *IEEE Transactions on Communications*, vol. 23, no. 12, pp. 1417-1433, December 1975.
- [3] J. Chen, S.-T. Sheu, and C.-A. Yang, “A New Multichannel Access Protocol for IEEE 802.11 Ad Hoc Wireless LANs,” in *Proceedings of the IEEE International Symposium on Personal, Indoor and Mobile Radio Communication*, vol. 3, pp. 2291- 2296, September 2003.
- [4] A. Raniwala, K. Gopalan, and T.-C. Chiueh, “Centralized Channel Assignment and Routing Algorithms for Multi-Channel Wireless Mesh Networks,” in *Mobile Computing and Communication Review*, vol. 8, no. 2, pp. 50-65, April 2004.
- [5] C. E. Perkins and P. Bhagwat, “Highly Dynamic Destination-Sequenced Distance-Vector Routing (DSDV) for Mobile Computers,” in *Computer Communication Review*, vol. 24, no. 4, pp. 234-244, October 1994.
- [6] T. Lin, “Mobile Ad-hoc Network Routing Protocols: Methodologies and Applications,” Ph.D. Dissertation, Virginia Polytechnic Institute and State University, 2004. Available at <http://scholar.lib.vt.edu/theses/available/etd-03262004-144048/>.
- [7] T. Clausen and P. Jacquet, “Optimized Link State Routing Protocol (OLSR),” Internet Engineering Task Force RFC 3626, October 2003. Available at <http://www.ietf.org/rfc/rfc3626.txt>.
- [8] M. Gast, *802.11 Wireless Networks – Definitive Guide*, O’Reilly, Sebastopol CA, pp. 10-13, 2002.
- [9] Internet Engineering Task Force MANET Working Group, “Mobile Ad-hoc Networks (manet),” December 2001. Available at <http://www.ietf.org/html.charters/-manet-charter.html>.
- [10] E. M. Royer and C.-K. Toh, “A Review of Current Routing Protocols for Ad-Hoc Mobile Wireless Networks,” in *IEEE Personal Communications*, vol. 6, no. 2, pp. 46-55, April 1999.

- [11] D. B. Johnson, D. A. Maltz, Y. C. Hu, and J. G. Jetcheva, "The Dynamic Source Routing Protocol for Mobile Ad Hoc Networks (DSR)," Internet Engineering Task Force draft, February 2002. Available at <http://www.ietf.org/internet-drafts/draft-ietf-manet-dsr-10.txt>.
- [12] C. E. Perkins, E. M. Belding-Royer, and S. R. Das, "Ad Hoc On-Demand Distance Vector (AODV) Routing," Internet Engineering Task Force RFC 3561, July 2003. Available at <http://www.ietf.org/rfc/rfc3561.txt>.
- [13] R. G. Ogier, F. L. Templin, B. Bellur, and M. G. Lewis, "Topology Dissemination Based on Reverse-Path Forwarding (TBRPF)," RFC 3684, February 2004. Available at <http://www.ietf.org/rfc/rfc3684.txt>.
- [14] T. Lin, S. F. Midkiff, and J. S. Park, "Approximation Algorithms for Minimal Connected Dominating Sets and Application with Routing Protocol in Wireless Ad Hoc Networks," in *Proceedings of IEEE International Performance Computing and Communications Conference*, pp. 157-164, April 2003.
- [15] V. Ramasubramanian, Z. J. Haas, E. G. Sirer, "SHARP: A Hybrid Adaptive Routing Protocol for Mobile Ad Hoc Networks," in *Proceedings of the 4th ACM International Symposium on Mobile Ad Hoc Networking and Computing*, pp. 303-314, June 2003.
- [16] L. R. Ford, Jr. and D. R. Fulkerson, *Flows in Networks*, Princeton University Press, Princeton, NJ, 1962.
- [17] D. B. West, *Introduction to Graph Theory*, 2nd edition, Prentice Hall, Upper Saddle River, NJ, 2001.
- [18] J. Moy, "OSPF Version 2," Internet Engineering Task Force RFC 2328, April 1998. Available at <http://www.ietf.org/rfc/rfc2328.txt>.
- [19] J. Li, Z. J. Haas, M. Sheng, and Y. Chen, "Performance Evaluation of Modified IEEE 802.11 MAC for Multi-Channel Multi-Hop Ad Hoc Network," in *Proceedings of the International Conference on Advanced Information Networking and Applications*, pp. 312-317, March 2003.
- [20] P. Bahl, R. Chandra, and J. Dunagan, "SSCH: Slotted Seeded Channel Hopping for Capacity Improvement in IEEE 802.11 Ad-Hoc Wireless Networks," in *Proceedings of ACM Mobicom*, pp. 216-226, September 2002.
- [21] S. Wiwatthanasaranrom and A. Phonphoem, "Multichannel MAC Protocol for Ad-Hoc Wireless Networks", in *Proceedings of the National Computer Science and Engineering Conference*, pp. 115-120, October 2003.
- [22] J. So and N. Vaidya, "Multi-Channel MAC for Ad Hoc Networks: Handling Multi-Channel Hidden Terminals Using A Single Transceiver," in *Proceedings of the ACM*

- International. Symposium on Mobile Ad Hoc Networking and Computing*, pp. 222-233, May 2004.
- [23] R. Chandra, P. Bahl, and P. Bahl, "MultiNet: Connecting to Multiple IEEE 802.11 Networks Using a Single Wireless Card," in *Proceedings of IEEE INFOCOM*, vol. 2, pp. 882 - 893, March 2004.
- [24] W.-C. Hung, K. L. E. Law, and A. J. Leon-Garcia, "A Dynamic Multi-Channel MAC for Ad Hoc LANs," in *Proceedings of 21st Biennial Symposium on Communications*, pp. 31-35, April 2002.
- [25] N. Jain, S. R. Das, and A. Nasipuri, "A Multichannel CSMA MAC Protocol with Receiver-Based Channel Selection for Multihop Wireless Networks," in *Proceedings of the International Conference on Computer Communications and Networks*, pp. 432-439, October 2001.
- [26] F. Herzel, G. Fischer, and H. Gustat. "An Integrated CMOS RF Synthesizer for 802.11a Wireless LAN," in *IEEE Journal of Solid-State Circuits*, vol. 38, no. 10, pp. 1767-1770, October 2003.
- [27] S.-L. Wu, C.-Y. Lin, Y.-C. Tseng, and J.-P. Sheu, "A New Multi-Channel MAC Protocol with On-Demand Channel Assignment for Multi-Hop Mobile Ad Hoc Networks," in *Proceedings of the International Symposium on Parallel Architectures, Algorithms and Networks*, pp. 232-239, December 2000.
- [28] J. S. Pathmasuntharam, A. Das, and A. K. Gupta, "Primary Channel Assignment based MAC (PCAM) - A Multi-Channel MAC Protocol for Multi-Hop Wireless Networks," in *Proceedings of the IEEE Wireless Communications and Networking Conference*, vol. 2, pp. 1110-1115, March 2004.
- [29] A. Adya, P. Bahl, J. Padhye, A. Wolman, and L. Zhou, "A Multi-radio Unification Protocol for IEEE 802.11 Wireless Networks," in *Proceedings International Conference on Broadband Networks*, pp. 344-354, October 2004.
- [30] H. Zhai, J. Wang, Y. Fang, and D. Wu, "A Dual-Channel MAC Protocol for Mobile Ad Hoc Networks," in *Proceedings of the IEEE Workshop on Wireless Ad Hoc and Sensor Networks, in conjunction with IEEE Globecom*, pp. 27-32, November 2004.
- [31] P. Kyasanur, J. Padhye, and P. Bahl, "On the Efficacy of Separating Control and Data into Different Frequency Bands," in *Proceedings International Conference on Broadband Networks*, pp 646-655, October 2005.
- [32] J. Deng, Y. S. Han, and Z. J. Haas, "Analyzing Split Channel Medium Access Control Schemes with ALOHA Reservation," in *Ad-Hoc, Mobile, and Wireless Networks*, S. Pierre, M. Barbeau, and E. Kranakis, eds., 2003, Lecture Notes in Computer Science, vol. 2865, pp. 128-139, October 2003.

- [33] X. Yang and N. H. Vaidya, "Explicit and Implicit Pipelining for Wireless Medium Access Control," in *Proceedings of the IEEE Vehicular Technology Conference*, vol. 3, pp 1427-1431, October 2003.
- [34] J. W. Tantra, C. H. Foh, and B. S. Lee, "An Efficient Scheduling Scheme for High Speed IEEE 802.11 WLANs," in *Proceedings of the IEEE Vehicular Technology Conference*, vol. 4, pp. 2589-2593, October 2003.
- [35] I. F. Akyildiz, X. Wang, and W. Wang, "Wireless Mesh Networks: A Survey," *Computer Networks and ISDN Systems Archive*, vol. 47, pp. 445- 487, March 2005.
- [36] I. F. Akyildiz, W. Su, Y. Sankarasubramaniam, and E. Cayirci, "A Survey on Sensor Networks," in *IEEE Communications Magazine*, vol. 40, no. 8, pp. 102-114, August 2002.
- [37] I. Katzela and M. Naghshineh, "Channel Assignment Schemes for Cellular Mobile Telecommunication Systems: A Comprehensive Survey," in *IEEE Personal Communications*, vol. 3, no. 3, pp. 10-31, June 1996.
- [38] M. Alicherry, R. Bhatia, and L. Li, "Joint Channel Assignment and Routing for Throughput Optimization in Multi-radio Wireless Mesh Networks," in *Proceedings of the ACM International Conference on Mobile Computing and Networking*, pp. 58-72, August 2005.
- [39] J. Tang, G. Xue, and W. Zhang, "Interference-Aware Topology Control and QoS Routing in Multi-Channel Wireless Mesh Networks," in *Proceedings of the ACM International Symposium on Mobile Ad Hoc Networking and Computing*, pp. 68-77, May 2005.
- [40] J. So and N. H. Vaidya, "Routing and Channel Assignment in Multi-channel Multi-hop Wireless Networks with Single-NIC Devices," Technical Report, University of Illinois at Urbana-Champaign, December 2004. [http://www.crhc.uiuc.edu/wireless/papers/hybrid\\_jungmin.pdf](http://www.crhc.uiuc.edu/wireless/papers/hybrid_jungmin.pdf)
- [41] P. Kyasanur and N. H. Vaidya, "Routing and Interface Assignment in Multi-Channel Multi-Interface Wireless Networks," in *Proceedings of the IEEE Wireless Communication and Networking Conference*, vol. 4, pp. 2051-2056, March 2005.
- [42] Paul A. Fishwick, *Simulation Model Design and Execution*, Prentice Hall, Upper Saddle River, NJ, 1995.
- [43] R. Draves, J. Padhye, and B. Zill, "Routing in Multi-Radio, Multi-Hop Wireless Mesh Networks," in *Proceedings of the Annual International Conference on Mobile Computing and Networking*, pp. 114-128, September 2004.
- [44] M. X. Gong and S. F. Midkiff, "Distributed Channel Assignment Protocols: A Cross-Layer Approach," in *Proceedings of IEEE Wireless Communications and Network-*

- ing Conference, vol. 4, pp. 2195-2200, March 2005.
- [45] L. Hu, "Distributed Code Assignments for CDMA Packet Radio Networks," in *Proceedings of INFOCOM*, vol. 3, pp. 1500-1509, April 1991.
- [46] J. J. Garcia-Luna-Aceves and J. Raju, "Distributed Assignment of Codes for Multihop Packet-radio Networks," in *Proceedings of Military Communication Conference*, vol. 1, pp. 262-273, October 1997.
- [47] J. Weston, J. Dean, J. Macker, B. Adamson, ProteanForge: Project Info-OLSR. Available at <http://pf.itd.nrl.navy.mil/projects.php>.
- [48] M. Kodialam, T. Nandagopal, "Characterizing the Capacity Region in Multi-radio Multi-channel Wireless Mesh Networks," in *Proceedings of the International Conference on Mobile Computing and Networking*, pp. 73-87, August 2005
- [49] P. Bahl, A. Adya, J. Padhye, and A. Wolman, "Reconsidering Wireless Systems with Multiple Radios," in *ACM SIGCOMM Computer Communications Review*, vol. 34, no. 5, pp. 39-46, October 2004.
- [50] A. Nasipuri, J. Zhuang, and S. R. Das, "A Multichannel CSMA MAC Protocol for Multihop Wireless Networks," in *Proceedings of Wireless Communications and Networking Conference*, vol. 3, pp. 1402-1406, September 1999.
- [51] A. Nasipuri and S. R. Das, "Multichannel CSMA with Signal Power-based Channel Selection for Multihop Wireless Networks", in *Proceedings of the IEEE Vehicular Technology Conference*, vol. 1, pp. 211-218, September 2000.
- [52] T. C. Tseng, C. S. Hsu, and T. Y. Hsieh, "Power-Saving Protocols for IEEE 802.11-Based Multi-Hop Ad Hoc Networks," in *Proceedings of IEEE INFOCOM*, vol. 1, pp. 200-209, June 2002.
- [53] U. Lee, S. F. Midkiff, and T. Lin, "OSPF-MCDS-MC: A Routing Protocol for Multi-Channel Wireless Ad-Hoc Networks," in *IEEE Consumer Communications and Networking Conference*, vol. 1, pp. 426-430, January 2006
- [54] U. Lee and S. F. Midkiff, "OLSR-MC: A Routing Protocol for Multi-Channel Wireless Ad-Hoc Networks," in *Proceedings of the IEEE Wireless Communication and Networking Conference*, April 2006
- [55] H. Woesner, J. P. Ebert, M. Schlager, and A. Wolisz, "Power-Saving Mechanisms in Emerging Standards for Wireless LANs: The MAC Level Perspective," in *IEEE Personal Communications*, vol. 5, issue 3, pp. 40-48, June 1998.
- [56] S. Singh and C. S. Raghavendra, "Power Efficient MAC Protocol for Multihop Radio Networks," in *Proceedings of IEEE International Personal, Indoor and Mobile Radio Communications Conference*, pp. 153-157, September 1998.
- [57] C. F. Chiasserini and R. R. Rao, "A Distributed Power Management Policy for Wire-

- less Ad Hoc Networks,” in *Proceedings of the IEEE Wireless Communication and Networking Conference*, pp. 1209–1213, September 2000.
- [58] J. R. Lorch and A. J. Smith, “Software Strategies for Portable Computer Energy Management,” in *IEEE Personal Communications*, vol. 5, issue 3, pp. 60–73, June 1998.
- [59] U. Lee and S. F. Midkiff, “Channel Distribution Fairness in Multi-Channel Wireless Ad-hoc Networks Using a Channel Distribution Index,” in *Proceedings of the IEEE International Performance Computing and Communications Conference*, pp. 111–118, April 2006.
- [60] U. Lee, S. F. Midkiff, and J. S. Park, “A Proactive Routing Protocol for Multi-Channel Wireless Ad-hoc Networks (DSDV-MC),” in *Proceedings of the International Conference on Information Technology Coding and Computing*, vol. 2, pp. 710–715, April 2005.
- [61] R. Jain, D. M. Chiu, and W. R. Hawe, “A Quantitative Measure of Fairness and Discrimination for Resource Allocation in Shared Systems,” Technical Report, Digital Equipment Corporation, DEC-TR-301, September 1984. Available at <http://www.cse.wustl.edu/~jain/papers/fairness.htm>
- [62] D. Chiu and R. Jain, “Analysis of the Increase and Decrease Algorithms for congestion avoidance in computer networks,” in *Computer Networks and ISDN Systems*, vol. 17, no.1, pp. 1–14, June 1989.
- [63] T. Camp, J. Boleng, and V. Davies, “A Survey of Mobility Models for Ad Hoc Network Research,” in *Wireless Communication & Mobile Computing: Special issue on Mobile Ad Hoc Networking: Research, Trends and Applications*, vol. 2, no. 5, pp. 483–502, September 2002.
- [64] T. Lin and S. Midkiff, “Mobility versus Link Stability in Simulation of Mobile Ad Hoc Networks,” in *Proceedings Communication Networks and Distributed Systems Modeling and Simulation Conference (CNDS)*, pp. 3–8, January 2003.
- [65] Q. Jiang and D. Manivannan, “Routing Protocols for Sensor Networks,” in *Proceedings IEEE Consumer Communications and Networking Conference*, pp. 93–98, January 2004.
- [66] UCB/LBNL/VINT, “Network Simulator (ns), version 2”. Available at <http://www.isi.edu/nsnam/ns/>.
- [67] CMU Monarch Group. CMU Monarch Extensions to ns. Available at <http://www.monarch.cs.cmu.edu/>.
- [68] D. C. Plummer, “An Ethernet Address Resolution Protocol,” Internet Engineering Task Force RFC 826, November 1982. Available at <http://www.ietf.org/rfc/rfc826.txt>.

- [69] T. Narten, E. Nordmark, and W. Simpson, "Neighbor Discovery for IP Version 6 (IPv6)," Internet Engineering Task Force RFC 2461, December 1998. Available at <http://www.ietf.org/rfc/rfc2461.txt>.
- [70] Red Hat Linux. Available at <http://www.redhat.com>.
- [71] A. Tirumala, F. Qin, J. Dugan, J. Ferguson, and K. Gibbs, Iperf Version 2.02, May 3, 2005. Available at <http://dast.nlanr.net/Projects/Iperf/>.
- [72] C. Barrett, M. Drozda, A. Marathe, and M. V. Marathe, "Characterizing the Interaction between Routing and MAC Protocols in Ad-hoc Networks," in *Proceedings of the ACM International Symposium on Mobile Ad Hoc Networking and Computing*, pp. 92-103, June 2003.
- [73] L. Qin and T. Kunz, "Survey on Mobile Ad Hoc Network Routing Protocols and Cross-Layer Design," Carleton University, Technical Report SCE-04-14, August 2004. Available at [http://wcrq.iust.ac.ir/DigitalLib/Survey on Mobile Ad Hoc Network Routing Protocols and Cross-Layer.pdf](http://wcrq.iust.ac.ir/DigitalLib/Survey%20on%20Mobile%20Ad%20Hoc%20Network%20Routing%20Protocols%20and%20Cross-Layer.pdf)
- [74] V. Kawadia and P. R. Kumar, "A Cautionary Perspective on Cross Layer Design," in *IEEE Wireless Communication Magazine*, vol. 12, no. 1, pp. 3-11, February 2005.
- [75] J. D. Prado and S. Choi, "Experimental Study on Co-existence of 802.11b with Alien Devices," in *Proceedings of IEEE Vehicular Technology Conference*, pp. 977-981, October 2001.
- [76] A. Raniwala and T. Chiueh, "Architecture and Algorithms for an IEEE 802.11-Based Multi-Channel Wireless Mesh Network," in *Proceedings of IEEE INFOCOM*, vol. 3, pp. 2223-2234, March 2005.
- [77] Y. Li, H. Wu, D. Perkins, N. Tzeng, and M. Bayoumi, "MAC-SCC: Medium Access Control with a Separate Control Channel for Multihop Wireless Networks," in *Proceedings of International Conference on Distributed Computing Systems Workshops*, pp. 764-777, May 2003.
- [78] Module-HOWTO, Jul. 2005, Available at <http://www.tldp.org/HOWTO/Module-HOWTO/index.html>.

# Curriculum Vitae

Unghee Lee received his B.S.E and M.S. degree in Computer Science and Engineering from INHA University at Incheon, Korea in 1996 and 1998, respectively. Mr. Lee received the Honor Student award at INHA university. Mr. Lee worked as an associate research engineer at LG Electronics for 4 years. His research interests include multi-channel routing and MAC protocols, MANETs, and TCP performance over wireless networks.

## Publications

1. Unghee Lee, Scott F. Midkiff, and Tao Lin, "Routing in Multi-Channel Wireless Ad-hoc Networks: OSPF-MCDS-MC," *Journal of Communications (JCM, ISSN 1796-2021)*, issue 2, 2006
2. Unghee Lee, Scott F. Midkiff, "Channel Distribution Fairness in Multi-Channel Wireless Ad-hoc Networks Using a Channel Distribution Index," in *IEEE International Performance Computing and Communications Conference (IPCCC)*, April 2006.
3. Unghee Lee, Scott F. Midkiff, "OLSR-MC: A Routing Protocol for Multi-Channel Wireless Ad-Hoc Networks," in *IEEE Wireless Communication and Networking Conference (WCNC)*, April 2006.
4. Unghee Lee, Scott F. Midkiff, and Tao Lin, "OSPF-MCDS-MC: A Routing Protocol for Multi-Channel Wireless Ad-Hoc Networks," in *IEEE Consumer Communications and Networking Conference (CCNC)*, vol. 1, pp. 426 – 430, January 2006.
5. Unghee Lee, Scott F. Midkiff, and Jahng S. Park, "A Proactive Routing Protocol for Multi-Channel Wireless Ad-hoc Networks (DSDV-MC)," in *International Conference on Information Technology Coding and Computing (ITCC)*, Vol. 2, pp. 710-715, April 2005.
6. Unghee Lee and Scott F. Midkiff, "Quality of Service for TCP over Satellite Links in Congested Networks," in *IEEE Wireless Communications and Networking Conference (WCNC)*, Vol. 3, pp. 1515-1520, March 2005.
7. U. H. Lee and Jae-Yong, Lee, "The Design of Group Polling for SNMP", *Journal of the Computer Engineering Application Research Center*, pp.111-117, February 1998
8. U. H. Lee and Kyoon-Ha. Lee, "Improvement of Data Transmission Method between Mobile Stations during PS (Power Saving) mode in IEEE 802.11 Wireless LAN", in

*Journal of the Korean Institute of Communication Sciences*, Vol. 16, pp.145-148,  
September 1997.