

Chapter Two

Synchronous Rectification

The conduction loss of diode rectifier contributes significantly to the overall power loss in a power supply, especially in low output-voltage applications. The rectifier conduction loss is proportional to the product of its forward-voltage drop, V_F , and the forward conduction current, I_F . On the other hand, operating in the MOSFET III quadrant, a synchronous rectifier presents a resistive i - v characteristics, as shown in Fig. 2.1. Under certain current level, the forward-voltage drop of a synchronous rectifier can be lower than that of a diode rectifier, and consequently reduces the rectifier conduction loss [A1]. Due to the fact that synchronous rectifiers are active devices, the design and utilization of synchronous rectification need to be properly addressed.

This chapter analyzes the application of synchronous rectification in two most popular isolated topologies, forward and flyback converters. The limits of efficiency improvements that can be obtained using synchronous rectification are determined. Conversion efficiencies of different implementations are compared, and verified with experimental evaluations.

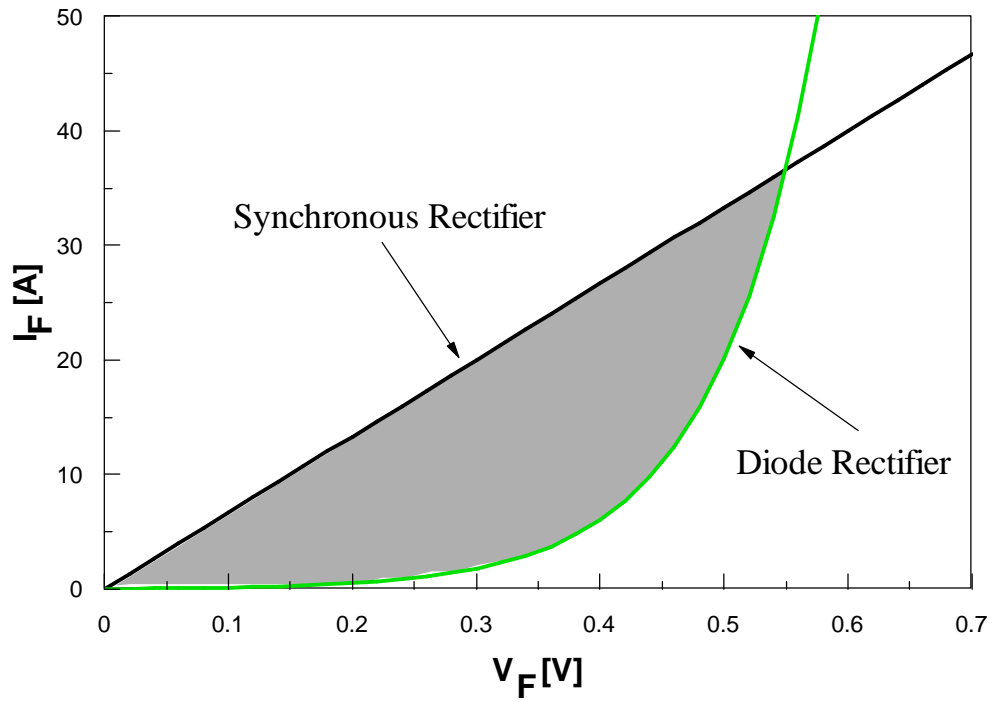

Figure 2.1. Forward-voltage comparison between synchronous rectifier and diode rectifier.
 ■ area has conduction loss saving by using synchronous rectifiers.

2.1. Synchronous Rectification in Forward Converter

In a continuing effort to increase the density and speed and to decrease power consumption of data-processing circuits, their power supply requirements are being reduced from 5V to 3.3V. The increased availability and use of 3.3-V logic ICs have spurred significant development and research efforts in the area of low-voltage power supplies. A number of approaches with different goals and levels of complexity have been taken in these designs. They range from simple dc/dc buck-converter add-on modules that convert outputs of existing power supplies to the modules that convert outputs of existing power supplies to the required low voltage, to more sophisticated ac/dc converters with synchronous rectifiers (SRs).

A number of SR implementations have been described so far [A2-A14]. Based on the method employed in driving SRs, all of them can be classified into two groups: control-driven and self-driven. In a control-driven SR implementation, the SRs are driven by gate-drive signals derived from the gate-drive of the main switch. In a self-driven SR implementation, the SRs are driven directly with the secondary voltage of the transformer. As a result, the self-driven SR approach is very attractive since it is simple and requires a minimum number of components.

However, the performance of self-driven SRs depends on the resetting method of the power transformer since the freewheeling synchronous rectifier is driven by the reset voltage.

Ideally, it would be desirable that the resetting time be equal to the off-time of the primary switch. Then the output current would freewheel through the SR for the entire off (freewheeling) time.

The objective of this section is twofold. The first is to theoretically determine the limit of efficiency improvements that can be obtained from SRs. This limit is primarily a function of the output voltage, output current, on-resistance of the SR, and the forward-voltage drop of Schottky rectifiers replaced by SRs. The second objective is to compare conversion efficiencies of control-driven SRs with those of different self-driven SR implementations. Specifically, performance comparisons of the forward converters with RCD-clamp and active-clamp reset are made.

2.1.1. Synchronous Rectifier Implementations

A. Forward Converter with RCD Clamp and Self-Driven SRs

The forward converter with self-driven SRs and its key waveforms are shown in Fig. 2.2. In this circuit, synchronous rectifiers SR_2 (Q_2 and D_2) and SR_3 (Q_3 and D_3) are crosscoupled to the secondary winding of the transformer and are directly driven by the secondary voltage. Since no driver or control circuit is used to provide the gate-drive signals, this implementation of synchronous rectification is the simplest possible. However, its performance is strongly dependent on the method of the transformer core resetting, because the gate-drive signal for synchronous rectifier SR_3 is derived from the reset voltage.

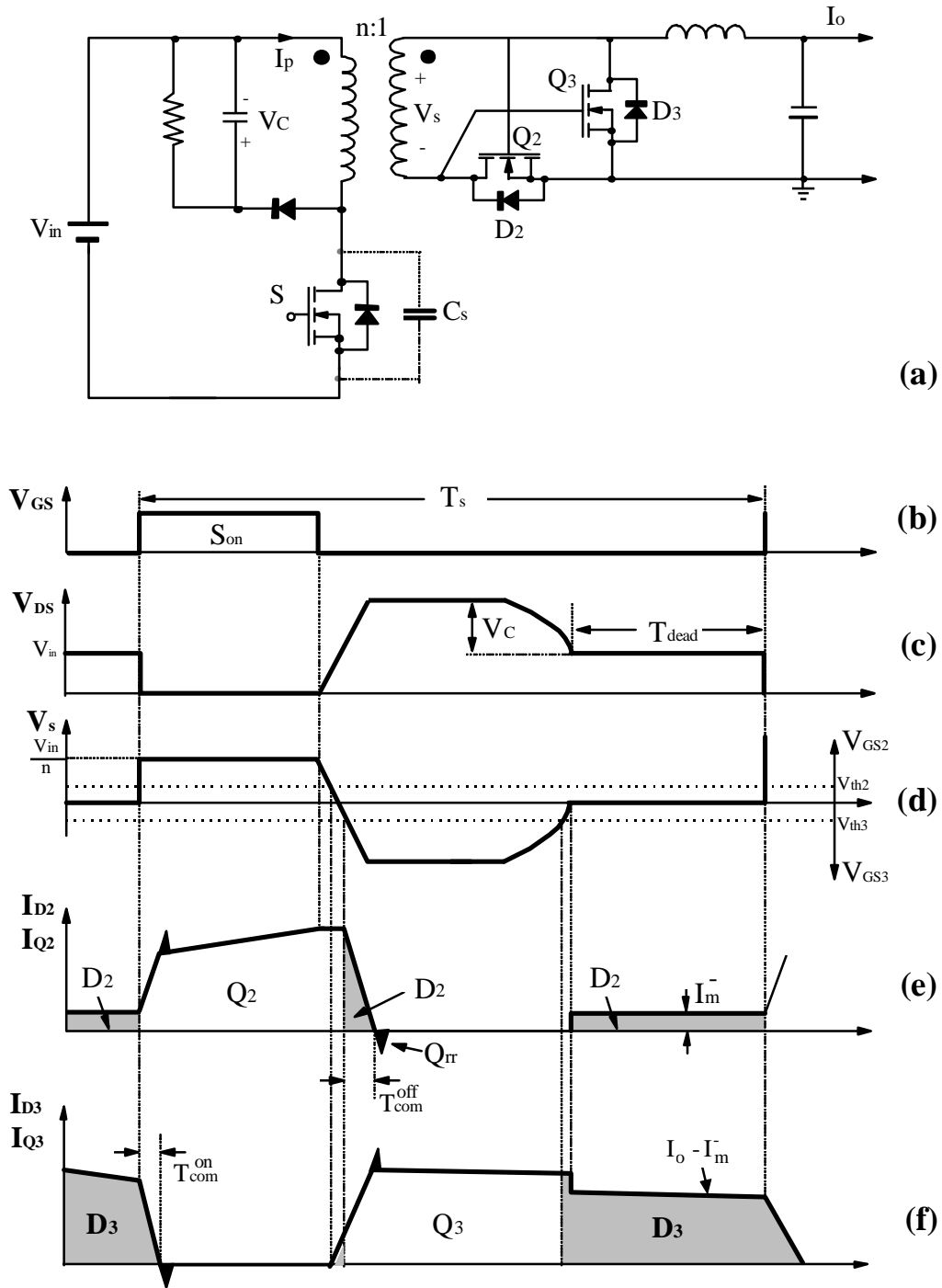

Figure 2.2. Forward converter with RCD clamp and self-driven SRs: (a) circuit diagram, (b) gate-drive signal, (c) drain-to-source voltage of primary switch, (d) secondary winding voltage, (e) current through SR_2 , and (f) current through SR_3 . C_s represents total capacitance seen at drain of MOSFET. Note that, for clarity, commutation times T_{com}^{on} and T_{com}^{off} are shown exaggerated.

As can be seen from the waveform in Fig. 2.2(e), once the transformer reset is completed, the magnetizing current of the transformer, I_m^- , starts flowing through the body diode of SR_2 [A17]. The magnitude of this current is given by [A17]:

$$I_m^- = N \frac{V_C}{\sqrt{L_m / C_s}} \quad (2-1)$$

where N is the turns ratio of the transformer, V_C is the transformer reset voltage, L_m is magnetizing inductance of the transformer, and C_s is the total capacitance seen at the drain of the primary switch. This capacitance is the sum of the output capacitance of the primary switch (C_{oss}), winding capacitance of the transformer (C_w), the clamp-diode junction capacitance (C_D), reflected input capacitance of SR_3 ($C_{iss}^{Q_3} / N^2$), and reflected output capacitance of SR_2 ($C_{oss}^{Q_2} / N^2$).

Also, as can be seen from the waveforms in Fig. 2.2(f), after the transformer reset is completed, the difference between load current I_o and magnetizing current I_m^- is diverted from transistor Q_3 to the body diode, D_3 , of SR_3 . Due to relatively high forward-voltage drops of the body diodes of SR_2 and SR_3 , the efficiency of synchronous rectification is reduced. The efficiency loss due to the body-diode conduction depends on the duration of the dead time (T_{dead}) and the forward-voltage drops of the body diodes (V_{BD}). This loss can be minimized by connecting Schottky diodes in parallel with SR_2 and/or SR_3 or by minimizing the conduction times of D_2 and D_3 . While the conduction time of D_3 can be minimized either by driving Q_3 by an external gate-drive signal or by minimizing the dead time by employing a different reset scheme [A9, A18], the

conduction time of D_2 can be shortened only by employing a transformer reset scheme that minimizes the dead time, as will be discussed in more detail in the following subsections. However, it should be noted that for load currents much greater than magnetizing current I_m^- , the efficiency loss occurring during the dead time due to the conduction of D_3 is much greater than that of D_2 . Since for properly designed converter I_m^- is usually less than 2A, the effect of D_2 conduction loss due to I_m^- on the efficiency is relatively small at output currents exceeding 15 to 20 A.

The conduction losses of the body diodes of SR_2 and SR_3 are also dependent on the commutation time T_{com}^{on} and T_{com}^{off} shown in Figs. 2.2(e) and 2.2(f). In fact, the body diode of SR_2 , D_2 , conducts only during a brief period immediately after the primary switch is turned off and during the dead time. While the dead time is solely determined by the transformer reset voltage, the commutation time of D_2 after the turn-off of the primary switch depends on the fall time of the secondary voltage (see Fig 2.2(d)) and the commutation time (T_{com}^{off}) of the output current from diode D_2 to transistor Q_3 . Commutation time T_{com}^{off} is dependent on the secondary-side inductance that consists of the leakage inductance of the transformer, the packaging inductance of the SRs, and the secondary-side interconnect inductance. The secondary-side inductance also determines the commutation time(T_{com}^{on}) which is required to commutate current from diode D_3 to transistor Q_2 after the primary switch is turned on. Since for output current $I_o \gg I_m^-$, the conduction loss of body diode D_3 during the dead time is much higher than the corresponding conduction loss of D_2 . As a result, the conduction loss of D_2 during commutation time T_{com}^{off} has a

much stronger effect on the total conduction loss of SR_2 compared to the effect that the conduction loss of D_3 during commutation time T_{com}^{on} has on the total loss of SR_3 . To minimize the commutation times, the total inductance of the secondary side should be minimized. Moreover, it is especially important to make the leakage inductance of the transformer small relative to the other circuit inductance to avoid a loss of gate-drive voltage for SRs as explained in [A7].

Finally, it should be noted that the conduction of the body diodes of SRs not only increases the conduction loss, but also introduces the power loss due to their reverse recovery. This loss, which appears on the body diode and the transistor of the opposite SR during the diode turn-off, is proportional to the recovered charge Q_{rr} indicated in Figs. 2.2(e) and 2.2(f), frequency, and secondary voltage [A20]. Therefore, it is relatively significant at full load and high line. The only method of eliminating this loss is to parallel the Schottky diodes to SR_2 and SR_3 .

B. Forward Converter with Active Clamp and Self-Driven SRs

The forward converter with active-clamp reset and its key waveforms are shown in Fig. 2.3. As can be seen, the active-clamp-reset approach minimizes the duration of the dead time since the transformer core is reset during almost the entire off time of the primary switch [A18, A19]. As a result, the conduction time of transistor Q_3 is maximized, the time during which D_2 is conducting magnetizing current is minimized. Consequently, the conversion efficiency of the converter with the active-clamp reset is improved relative to the RCD-clamp counterpart. Also, the active-clamp reset approach minimizes voltage stress on the primary switch. In addition, the primary switch in this circuit can be turned on at zero voltage by properly adjusting the

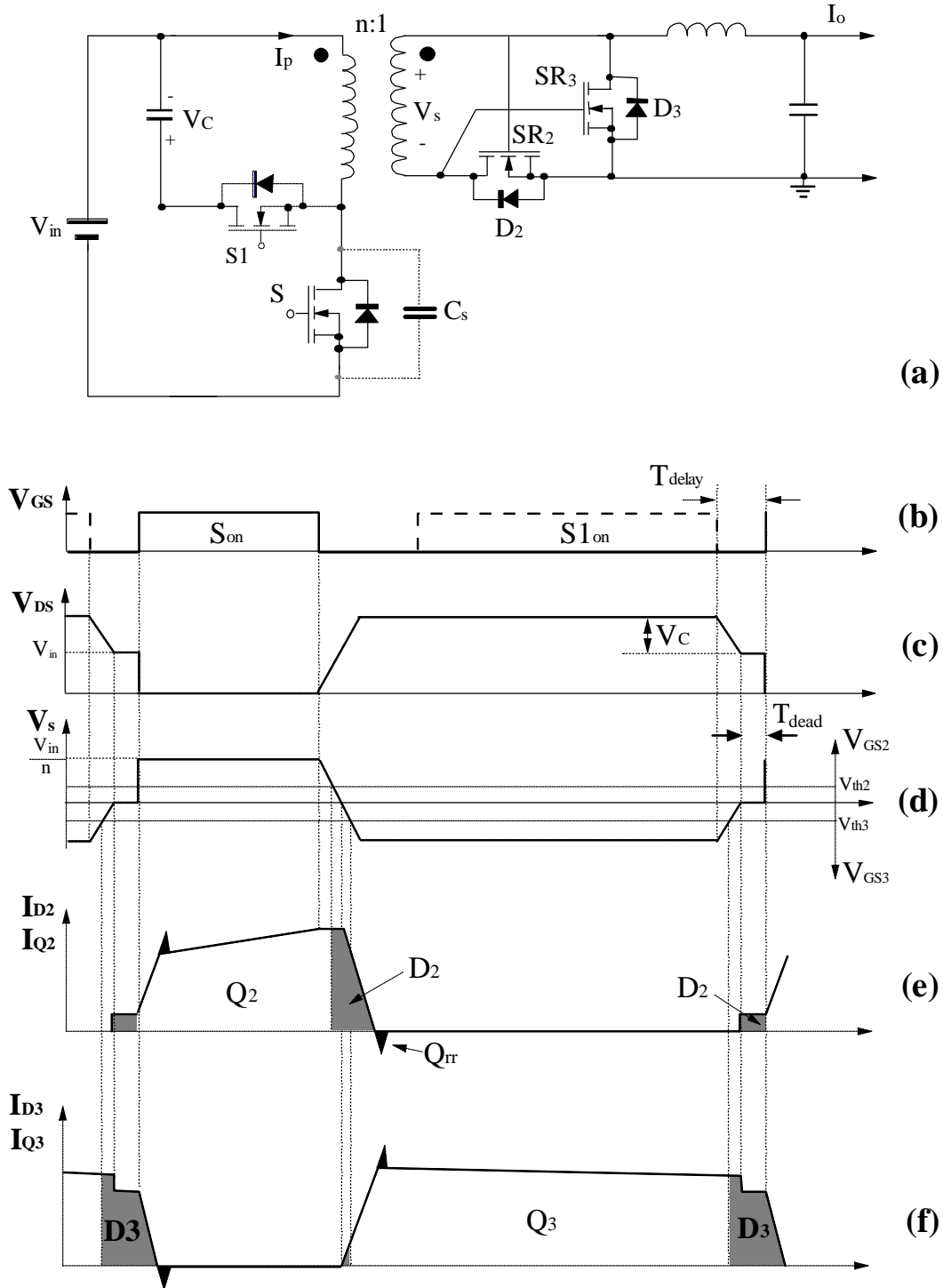

Figure 2.3. Forward converter with active-clamp and self-driven SRs: (a) circuit diagram, (b) gate-drive signals, (c) drain-to-source voltage of primary switch, (d) secondary winding voltage, (e) current through SR_2 , and (f) current through SR_3 .

magnetizing inductance of the transformer [A16]. However, the active clamp approach requires an extra switch and its associated gate drive, compared to the same circuit with the RCD-clamp reset. From this perspective, it is much simpler and more economical to use a Schottky diode in parallel with SR_2 to improve the efficiency of the RCD-clamp circuit than it is to implement the active clamp. Therefore, the active-clamp approach is a viable choice in synchronous-rectifier applications where voltage stress and soft-switching are important design considerations.

Generally, while self-driven SRs are simpler to implement, they are not suitable for applications with wide input-voltage variations. For the cross-coupled SRs shown in Figs. 2.2 and 2.3, the maximum feasible input-voltage range depends strongly on the output voltage. For higher output voltages, the input-voltage range is narrower. Namely, the gate-drive voltage of SR_2 is proportional to the input voltage. Also, the minimum secondary, (i.e., gate-drive) voltage that occurs at low line is dependent on the desired output voltage and the maximum duty cycle. If the input-voltage range is wide (e.g., $> 3:1$) and if the output voltage is relatively high (e.g., $> 5V$), the gate-drive voltage at the high line might exceed (or come close to) the maximum allowable gate-drive voltage. The effect of the output voltage on the amplitude of the gate-drive voltage can be eliminated by deriving the gate-drive signal for Q_2 from a separate winding. Also, the maximum gate-drive voltage can be limited by implementing a gate-to-source voltage-clamp circuit. However, all these modifications require additional components and/or a transformer with an increased number of windings, which makes the self-driven approach more complex. Therefore, the self-driven SRs are best suited for applications with a relatively narrow voltage range ($\leq 2:1$) and low output voltage.

C. Forward Converter with Control-Driven SRs

The forward converter with control-driven SRs and its key waveforms are shown in Fig. 2.4. In this circuit, transistors Q_2 and Q_3 are driven by gate-drive signals derived from the primary-switch gate drive. As a result, the conduction times of the synchronous rectifiers are independent of the transformer-resetting method, but solely depend on the timing of the gate-drive signals. However, as can be seen from Figs. 2.4(e) and 2.4(f), while driving the SRs from the control circuit results in the maximum conduction time of Q_3 , it has no effect on the conduction time of the magnetizing current through diode D_2 during the dead time. Namely, since during the dead time transistor Q_2 is off (gate-drive to Q_2 is low), the conduction of diode D_2 during the dead time with control-driven SRs (see Fig. 2.4) is exactly the same as for the self-driven SRs (see Fig. 2.2).

Ideally, the gate-drive timing of SRs should allow no conduction of the body diodes of the SRs except for the unavoidable conduction of D_2 during the dead time. This is only possible with a very precise gate-drive timing where the gate-drive of one SR is applied or terminated at the same instant the gate-drive of the other SR is terminated or applied. In practical applications, this ideally complementary drive is not possible. Accidental, brief overlapping of the gate-drive signals that turn on both SRs simultaneously would short the secondary, causing an increased secondary current, and thus would lower efficiency or, in severe cases, would cause converter failure. To avoid simultaneous conduction of SRs in practical applications, a delay between the gate-drive signals must be introduced. Since during the delay period no gate-drive signal is applied to the SRs, the body diodes of the SRs are conducting. This not only increase conduction

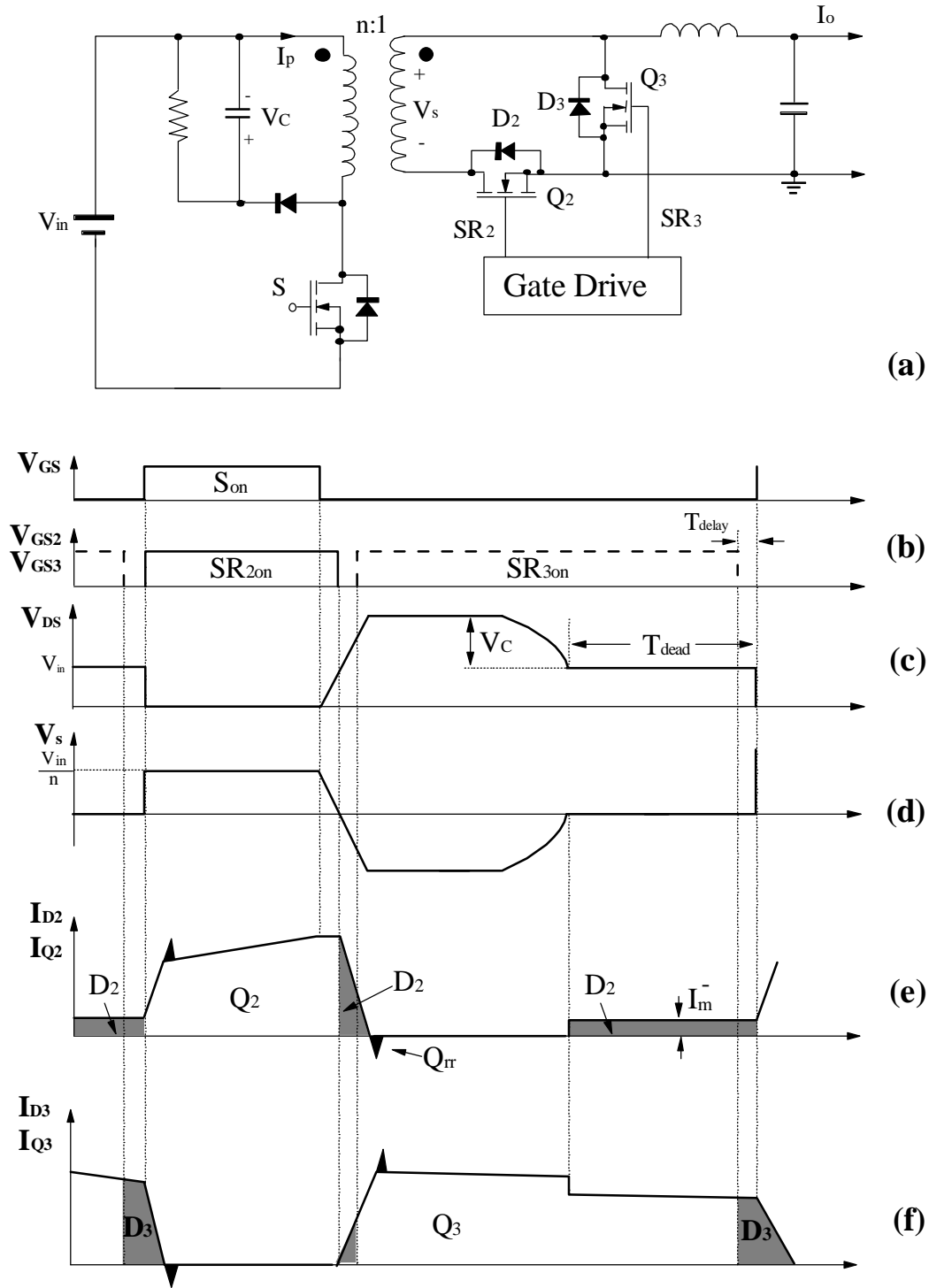

Figure 2.4. Forward converter with control-driven SRs: (a) circuit diagram, (b) gate-drive signals, (c) drain-to-source voltage of primary switch, (d) secondary winding voltage, (e) current through SR_2 , and (f) current through SR_3 .

loss but also introduces reverse-recovery loss. Therefore, the performance of control-driven SRs is strongly dependent on the timing of the gate drive.

2.1.2. Efficiency Limits of Synchronous Rectification

The efficiency improvement that can be achieved by replacing Schottky rectifiers with SRs is a complex function of many parameters. The most important are the output voltage, output current, SR on-resistance, forward-voltage drop of Schottkies that are being replaced by SRs, the transformer resetting method, efficiency of the converter with Schottkies, and implementation of SRs (i.e., with or without Schottkies in parallel with SRs). A thorough estimation of losses in Schottky rectifiers and self-driven SRs and their comparisons for a specific application are presented in [A7]. In this section, an estimate of overall efficiency improvements that can be achieved with different SRs implementations is presented.

Generally, the efficiency of a converter can be expressed as

$$\mathbf{h} = \frac{P_o}{P_o + P_{loss} + P_{REC}} \quad (2-2)$$

where P_o is the output power, P_{loss} is the total loss excluding the rectifier loss, and P_{REC} is the rectifier loss.

For a converter with Schottky rectifiers, the efficiency is

$$\mathbf{h}_{SH} = \frac{P_o}{P_o + P_{loss} + P_{SH}}. \quad (2-3)$$

Similarly, for the same converter with SRs, the efficiency is

$$\mathbf{h}_{SR} = \frac{P_o}{P_o + P_{loss} + P_{SR}}. \quad (2-4)$$

Eliminating P_{loss} from the above equations, the efficiency of the converter with SRs (\mathbf{h}_{SR}) can be expressed as a function of the efficiency of the converter with the Schottkies (\mathbf{h}_{SH})

$$\mathbf{h}_{SR} = \frac{P_o}{P_o / \mathbf{h}_{SH} - P_{SH} + P_{SR}}. \quad (2-5)$$

The power loss in the Schottky rectifiers can be calculated as

$$P_{SH} = V_{SH} I_o \quad (2-6)$$

where V_{SH} is the forward-voltage drop of the Schottkies, and I_o is the output current.

The power loss of the self-driven SRs, P_{SR}^{sd} , for both RCD-and active-clamp reset is given by:

$$P_{SR}^{sd} = R_{DS(on)} I_o^2 (1 - D_{dead}) + V_D I_o D_{dead} + P_{gate} + P_{RREC} \quad (2-7)$$

where $R_{DS(on)}$ is the on-resistance of SRs, $D_{dead} = T_{dead}/T_s$ is the dead-time duty cycle, V_D is the forward-voltage drop of the antiparallel diodes across SR_2 and SR_3 , P_{gate} is the gate-driven loss, and P_{RREC} is the power loss associated with the reverse-recovery of the body diodes of the SRs.

It should be noted that Eq. (2-7) is derived assuming that commutation times T_{com}^{on} and T_{com}^{off} are zero, that synchronous rectifiers SR_2 and SR_3 have identical on resistance ($R_{DS(on)2} = R_{DS(on)3} = R_{DS(on)}$), and that diodes D_2 and D_3 have identical voltage drops ($V_{D2} = V_{D3} = V_D$) which are independent of their currents. As a result of the last assumption ($V_{D2} = V_{D3} = V_D$), Eq. (2-7) does not explicitly show dependence on magnetizing current I_m^- , although it takes into account the conduction loss this current generates on diode D_2 .

For self-driven SRs with active-clamp reset, the dead time is very short relative to a switching period, and therefore, $D_{dead} \approx 0$. However, for the converter with the self-driven SRs and with the RCD-clamp reset, this duty cycle usually cannot be neglected. In this case, the loss depends on the duration of the dead time and V_D of the antiparallel diodes of the SRs. Generally, these diodes can be the body diodes of SRs ($V_D = V_{BD}$) or externally added Schottkies in parallel with SRs ($V_D = V_{SH}$).

The power loss of the control-driven SRs is given by:

$$\begin{aligned}
 P_{SR}^{cd} = & R_{DS(on)} I_o^2 (1 - D_{dead}) + R_{DS(on)} (I_o - I_m^-)^2 (D_{dead} - D_{delay}) \\
 & + V_D I_m^- D_{dead} + V_D (I_o - I_m^-) D_{delay} + P_{gate} + P_{RREC}
 \end{aligned} \tag{2-8}$$

where $D_{delay} = T_{delay}/T_s$ is the delay-time duty cycle, and T_{delay} is the delay time between the SR_3 gate-drive turn-off and SR_2 gate-drive turn-on as indicated in Fig. 2.4(b).

The gate-drive loss (P_{gate}) is a function of the gate-to-source voltage of SR, frequency, and gate charge required to charge SRs' capacitance to the gate-source voltage [A7]. A method of estimating this loss for self-driven SRs was presented in [A7]. According to those calculations, for low frequencies (< 300 kHz), the gate drive loss for today's SRs is small (< 0.5W), and for converters with an output power > 50W can be neglected. For control-driven SRs this loss is higher since it includes also the loss in the external drivers and their associated logic.

The reverse-recovery loss (P_{RREC}) is only presented in implementations where the body diode of the SR is conduction (no Schottky in parallel with SR). Even when the body diode is conducting, this loss is relatively small at low frequencies (< 100-150 kHz).

When the gate-drive loss and the reverse-recovery losses are neglected ($P_{gate} = P_{RREC} \approx 0$), the efficiency of the forward converter with the self-driven SRs for both RCD-and active-clamp implementations is

$$\frac{I}{h_{SR}^{sd}} = \frac{I}{h_{SH}} - \frac{V_{SH}}{V_o} \left[I - \frac{R_{DS(on)} I_o}{V_{SH}} (1 - D_{dead}) - \frac{V_D}{V_{SH}} D_{dead} \right]. \quad (2-9)$$

Since for the forward converter with self-driven SRs and active-clamp reset ($D_{dead} \approx 0$), its efficiency, h_{SR}^{acl} , can be expressed in the simplified form as

$$\frac{I}{\mathbf{h}_{SR}^{acl}} = \frac{I}{\mathbf{h}_{SH}} - \frac{V_{SH}}{V_o} \left[I - \frac{R_{DS(on)}I_o}{V_{SH}} \right]. \quad (2-10)$$

Equations (2-9) and (2-10) can be regarded as the best-case efficiency limits of different SR implementations. They are more accurate at low frequencies (<100-200 kHz), where the gate-drive loss and the reverse-recovery loss are small.

The efficiencies of the forward converter with control-driven SRs, \mathbf{h}_{SR}^{cd} , is given by:

$$\begin{aligned} \frac{I}{\mathbf{h}_{SR}^{cd}} = \frac{I}{\mathbf{h}_{SH}} - \frac{V_{SH}}{V_o} & \left[I - \frac{R_{DS(on)}I_o}{V_{SH}} (1 - D_{dead}) - \frac{R_{DS(on)}I_o}{V_{SH}} \left(1 - \frac{I_m^-}{I_o} \right)^2 (D_{dead} - D_{delay}) \right. \\ & \left. - \frac{V_D}{V_{SH}} \frac{I_m^-}{I_o} D_{dead} - \frac{V_D}{V_{SH}} \left(1 - \frac{I_m^-}{I_o} \right) D_{delay} \right]. \end{aligned} \quad (2-11)$$

If magnetizing current $I_m^- \ll I_o$ so that its loss can be neglected, and if the delay time is short so that $D_{delay} \approx 0$, Eq. (2-11) simplifies to Eq. (2-10).

Figure 2.5 shows the plots of Eq. (2-10). These plots present the efficiency of a converter with SRs (\mathbf{h}_{SR}) as a function of the normalized output voltage (V_o/V_{SH}). The efficiency of the converter with Schottky rectifiers (\mathbf{h}_{SH}) and $\mathbf{a} = I_o \cdot R_{DS(on)}$ are the parameters. Parameter \mathbf{a} represents the ratio of the forward-voltage drop of the SR at output current I_o to the forward-voltage drop of the Schottky. Obviously, \mathbf{a} needs to be less than 1 to obtain an efficiency improvement when Schottkies are replaced by SRs.

As can be seen, the efficiency improvement for a given \mathbf{a} and a given V_{SH} is lower at higher output voltages, V_o . Also, for the same output voltage, the efficiency gain achieved by

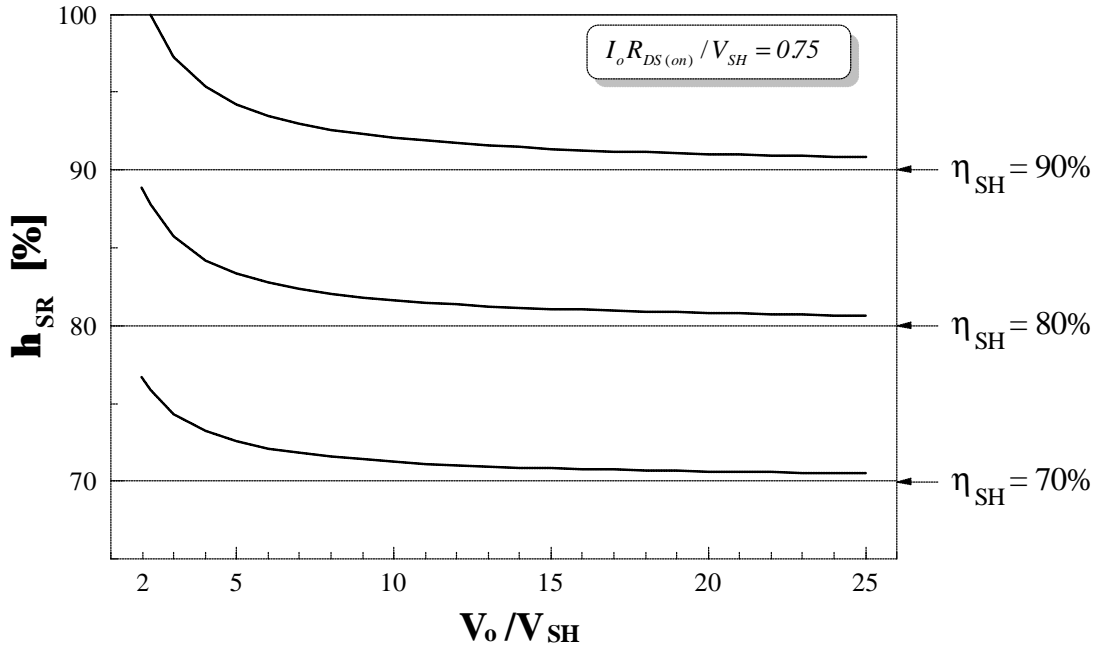

(a)

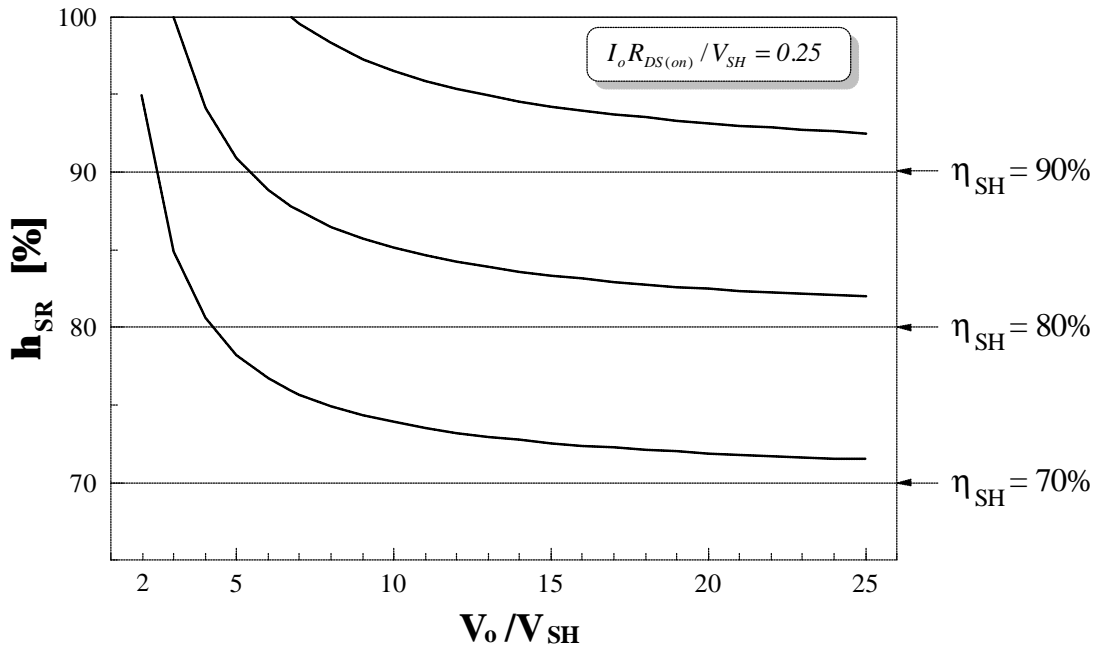

(b)

Figure 2.5. Efficiency limits of forward converter with self-driven SRs and active-clamp reset and control-driven SRs with small gate-drive timing delay ($D_{delay} \approx 0$) and magnetizing current $I_m^- \ll I_o$: (a) $\alpha = R_{DS(on)} \cdot I_o / V_{SH} = 0.75$, and (b) $\alpha = 0.25$.

synchronous rectification is higher for converters with higher efficiencies with Schottky diodes (h_{SH}), i.e., for converters where the total loss is dominated by the loss in the Schottky rectifiers ($P_{SH} > P_{loss}$). Similarly, the efficiency improvement is larger for smaller \mathbf{a} , i.e., for better SRs (smaller on-resistance) or lower output currents. For example, from the plot in Fig. 2.5(a) for a converter with $V_o = 3.3$ V, $I_o = 20$ A, and the efficiency with Schottky rectifiers of $h_{SH} = 0.8$, assuming that $V_{SH} = 0.4$ V, $R_{DS(on)} = 15$ m Ω (i.e., $\mathbf{a} = 0.75$ and $V_o/V_{SH} = 8.25$), the best-case efficiency improvement is only 2%.

Figure 2.6 shows the plots of Eq. (2-9) for $D_{dead} = 0.2$ for the SR implementation with a Schottky in parallel with SR_3 ($V_D = V_{SH}$) and without a Schottky ($V_D = V_{BD} = 3V_{SH}$). Also, for reference, the curves for $D_{dead} = 0$ (see Fig. 2.5) are shown. As can be seen, the efficiency of the converter with the RCD-clamp reset is strongly dependent on the SR implementation. For the implementation with Schottky diodes, the efficiency improvement is slightly lower than that of the control-driven SRs or self-driven SRs with an active-clamp reset. However, when the body diode of SR_3 is used to freewheel the output current, the difference is very significant. In fact, under certain conditions the efficiency of synchronous rectification can be lower than that of Schottky diodes, as illustrated in Fig. 2.6(a) for $V_D = V_{BD} = 3V_{SH}$.

2.1.3. Evaluation Results

Evaluations of the discussed SR implementations were performed on 100-kHz, 3.3-V/20-A forward-converter power stages designed to operate in the 200-400 Vdc input-voltage range. The power stages for both the RCD-clamp and active-clamp circuits were implemented using the

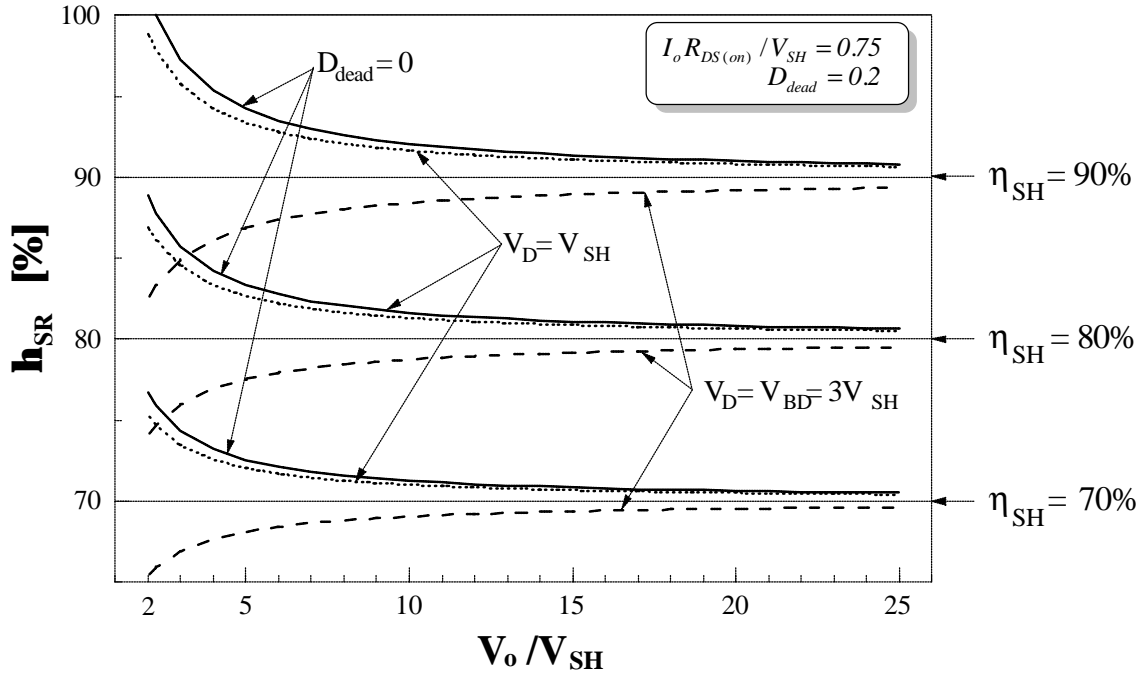

(a)

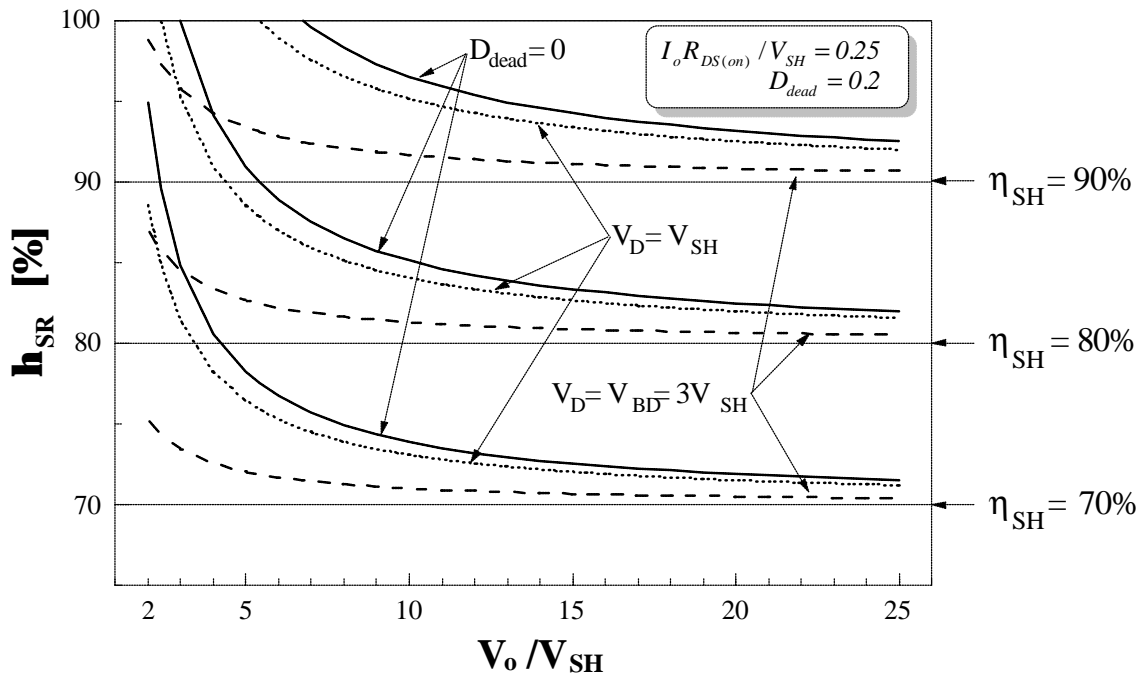

(b)

Figure 2.6. Efficiency limits of forward converter with self-driven SRs and RCD-clamp reset for $D_{dead} = 0.2$: (a) $a = R_{DS(on)} \cdot I_o / V_{SH} = 0.75$, and (b) $a = 0.25$.

IREPE50 MOSFETs ($BV_{DSS} = 800$ V, $I_D = 7.8$ A, and $R_{DS(on)} = 1.2 \Omega$) for the primary switches and IR82CQN30 Schottky diodes ($V_F = 0.3$ V @ 20 A and $T_j = 125$ °C) for the secondary-side rectifiers. The turns ratio of the transformer for the power stage with the RCD-clamp reset was $N_{rcd} = 24$, while the transformer turns ratio for the active-clamp-reset power stage was $N_{acl} = 28$. In the synchronous rectifier implementations of the experimental power stages, the Schottky diodes were replaced by the Siliconix synchronous rectifiers SMP60N03-10L ($R_{DS(on)} = 10$ m Ω , @ $T_j = 25$ °C, $V_{BD} = 0.9$ V @ 20 A and $T_j = 25$ °C, $C_{iss} = 2600$ pF @ $V_{DS} = 25$ V, and $C_{oss} = 1500$ pF @ $V_{DS} = 25$ V).

Figure 2.7(a) shows the measured efficiency of the experimental converter with the RCD-clamp reset and self-driven SRs at full output current ($I_o = 20$ A) as a function of the input voltage. Also shown in Fig. 2.7(a) is the efficiency of the converter with Schottky rectifiers. As can be seen, the efficiency of the SR implementation without Schottky diodes connected in parallel with the SRs is lower than that of the converter with the Schottky rectifiers. As has been explained earlier, the efficiency loss is caused by the excessive power loss in the body diode of SR_3 during the dead time. If Schottky diodes in parallel with SRs are added, the efficiency of synchronous rectification is improved. It is 0.7-1.2% higher than that of the Schottky rectifiers.

The calculated efficiencies of the converter with the SRs obtained from Eq. (2-9), are also shown in Fig. 2.7(a). As can be seen, they are in good agreement with the measured efficiencies for both the SR implementation with and without the Schottky diodes in parallel with the SRs. For the SR implementation without the Schottky diodes in parallel with the SRs, the maximum discrepancy between the calculated and measured efficiencies is 0.6%. It should be noted that the measured efficiencies in the entire input-voltage range are lower than the calculated efficiencies.

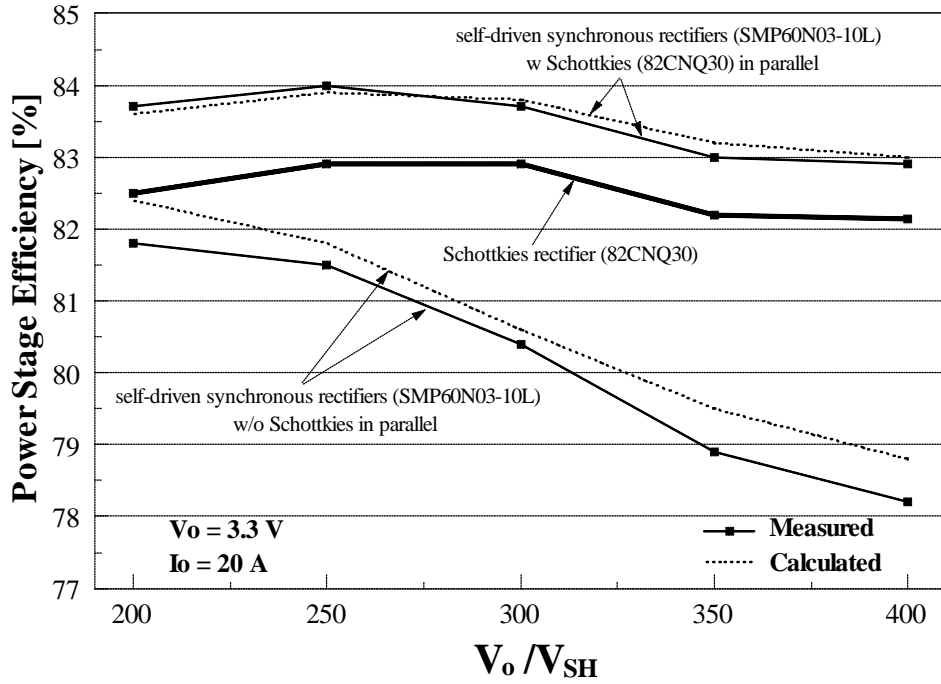

(a)

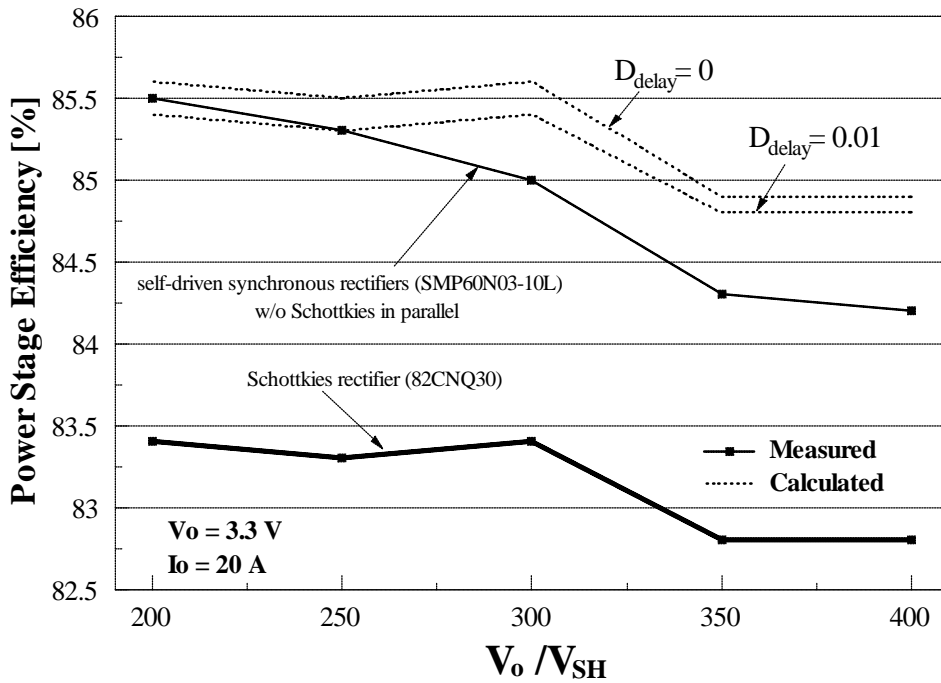

(b)

Figure 2.7. Measured efficiencies of forward-converter power stage with self-driven SRs: (a) with RCD-clamp reset, and (b) with active-clamp reset.

The primary reason for these discrepancies is the reverse-recovery loss of the SRs' body diodes which was neglected when deriving Eq. (2-9). An indirect proof for this claim is the fact that the discrepancies between calculated and measured efficiencies of the implementation with the Schottky diodes in parallel with the SRs are less than 0.2% in the entire input-voltage range. The improved agreement between the calculated and measured efficiencies in this case is the result of the suppressed conduction of the body diodes of the SRs, and consequently, of the elimination of their reverse-recovery losses.

It should be noted that the calculated efficiencies presented in Fig. 2.7(a), as well as in the following figures, were obtained by taking into account the temperature effects on the on-resistance of the synchronous rectifier and Schottky diode forward-voltage drop. Namely, during the efficiency measurements, the case temperatures of the SRs and Schottky diodes were also recorded along with the other relevant data (e.g., reset-voltage dead time duration). Based on the estimated losses and thermal resistance of the component packages, the junction temperatures of the SRs and Schottkies were determined, and their parameters were taken from the data sheets at the calculated junction temperatures. In addition, exactly the same set-up is used to measure the efficiencies of all experimental circuits, ensuring a high accuracy of the relative (comparison) measurements.

Figure 2.7(b) shows the measured efficiency of the experimental forward converter with the active-clamp reset and the self-driven SRs. As can be seen by comparing Figs. 2.7(a) and 2.7(b), the efficiency of this converter with the Schottky rectifiers is approximately 1% (83.5% versus 82.5%) higher compared to the corresponding converter with the RCD-clamp reset. This is primarily due to a reduced power loss on the primary side of the converter because of a higher

maximum duty cycle, and consequently, higher turns ratio of the transformer. The achieved efficiency improvement by synchronous rectification is approximately 1.5-2% depending on the input voltage.

The calculated efficiencies using Eqs. (2-9) and (2-10) are also shown in Fig. 2.7(b). As can be seen, the agreement between the calculated and measured efficiencies is good. As expected, better agreement was obtained by using a more accurate expression given by Eq. (2-9). In fact, the maximum discrepancy between the theoretical and experimental efficiencies for Eq. (2-9) is 0.7%. As in the case of the self-driven SRs with the RCD-clamp reset, this discrepancy can be attributed primarily to the reverse-recovery losses of the SRs which are not taken into account in Eqs. (2-9) and (2-10).

Figure 2.8 shows the measured efficiency of the experimental forward converter with the RCD-clamp and control-driven SRs for $T_{delay} = 0.25 \mu\text{s}$. From Fig. 2.8, at the input voltages below 250 V, the efficiency of the converter with SRs is slightly better than that of the converter with Schottkies. Specifically, the maximum efficiency improvement that occurs at low line (200 V) is 1.4%. However, for the input voltages higher than 250 V, the efficiency of the SR implementation is lower than the efficiency of the Schottky-diode implementation. The efficiency difference above 250 V increases as the input voltage increases, and reaches the maximum at high line (400 V), where the efficiency of the converter with SRs is 1.6% lower than the efficiency of the Schottky counterpart.

The calculated efficiency curve of the converter with SRs obtained from Eq. (2-11) is also shown in Fig. 2.8. Since the measured clamp voltage is $V_C \approx 300 \text{ V}$, the measured magnetizing inductance of the transformer is $L_m \approx 7.8 \text{ mH}$, and the estimated equivalent capacitance at the

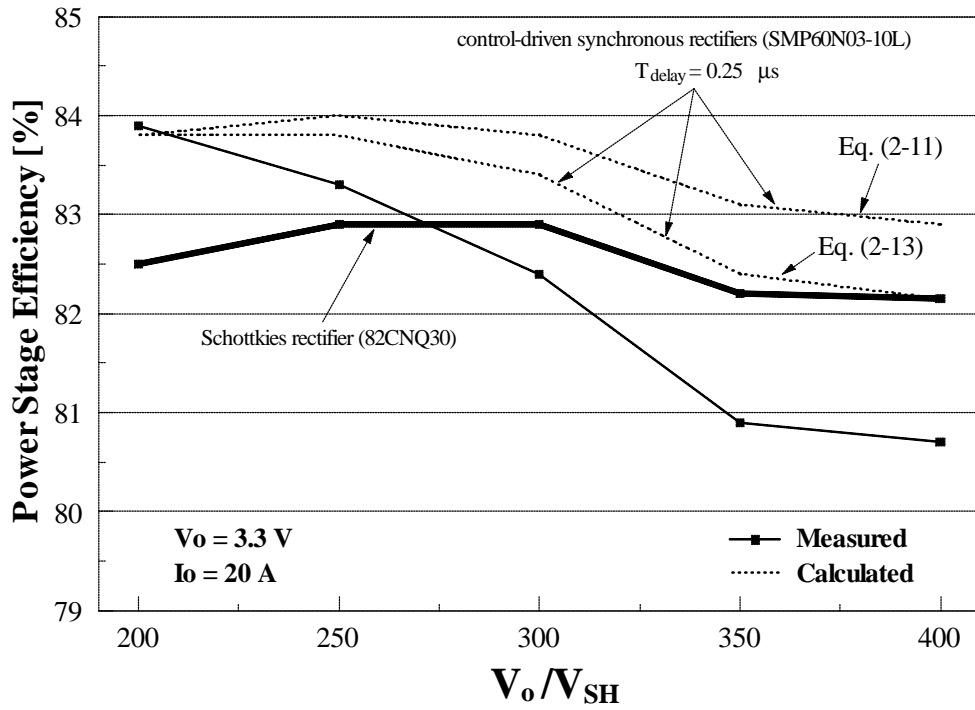

Figure 2.8. Measured and calculated efficiencies of forward-converter power stage with RCD-clamp reset and control-driven SRs for $T_{\text{delay}} = 0.25 \mu\text{s}$.

drain of the primary-switch MOSFET (including the voltage dependence of MOSFETs C_{oss}) is $C_S \approx 300$ pF, the value of magnetizing current I_m^- used in the efficiency calculations, according to Eq. (2-1), is

$$I_m^- = 24 \frac{300}{\sqrt{7.8 \cdot 10^{-3} / 300 \cdot 10^{-12}}} \approx 1.5 \text{ A} . \quad (2-12)$$

As can be seen from Fig. 2.8, the calculated efficiency curve is far off from the measured curve. In fact, the calculations predict the efficiency improvements over the entire input-voltage range when Schottkies are replaced by the SRs. The maximum discrepancy between the calculated and measured data occurs at high line (400 V), and it is 2.2%. The major reason for this discrepancy was found to be related to the power losses due to the parasitic oscillations on the secondary side during the dead time. These oscillations are generated by the parasitic resonance between the parasitic inductance (leakage, interconnect, and package) of the loop consisting of the secondary winding of the transformer, SR_2 , and SR_3 , and the secondary-side parasitic capacitance (parasitic capacitance of the winding and switches). To illustrate the problem, Fig. 2.9 shows the voltage waveforms of the primary switch and synchronous rectifiers SR_2 and SR_3 at $V_{in} = 300$ V. As can be seen from Fig. 2.9, the drain-to-source voltage of the primary switch shows oscillations during the dead time. Although not observable in Fig. 2.9, these oscillations are also present in the SR_2 and SR_3 voltage waveforms as seen in Fig. 2.10, which shows the blown-up SR_2 and SR_3 waveforms during the dead time. Since during the dead time, transistor Q_3 of SR_3 and diode D_2 of SR_2 are conducting, the secondary current during the dead time can be estimated by dividing the voltages across SR_3 by its on-resistance. As indicated

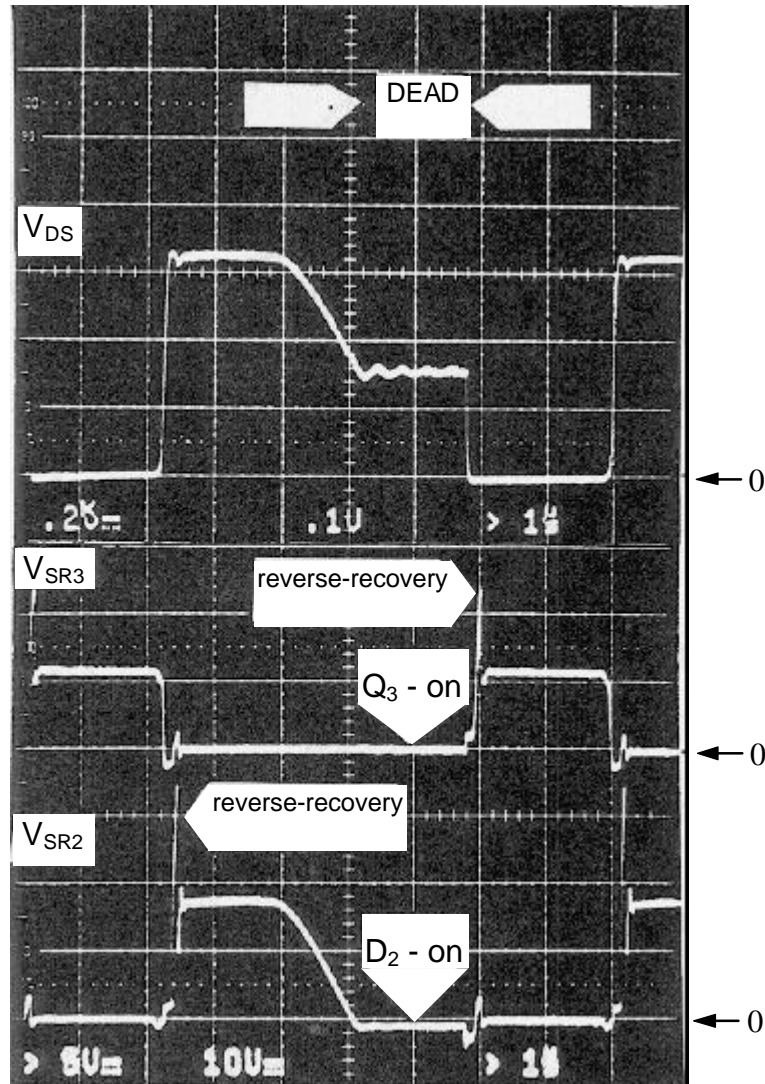

Figure 2.9. Oscillogram of key voltage waveforms of forward converter with RCD-clamp and control-driven SRs. From top to bottom: drain-to-source voltage of primary switch V_{DS} , SR_3 voltage V_{SR3} , and SR_2 voltage V_{SR2} . Scale: $V_{DS} = 200$ V/div.; $V_{SR3} = 10$ V/div.; $V_{SR2} = 6.6$ V/div. Time = $1.3 \mu\text{s}$.

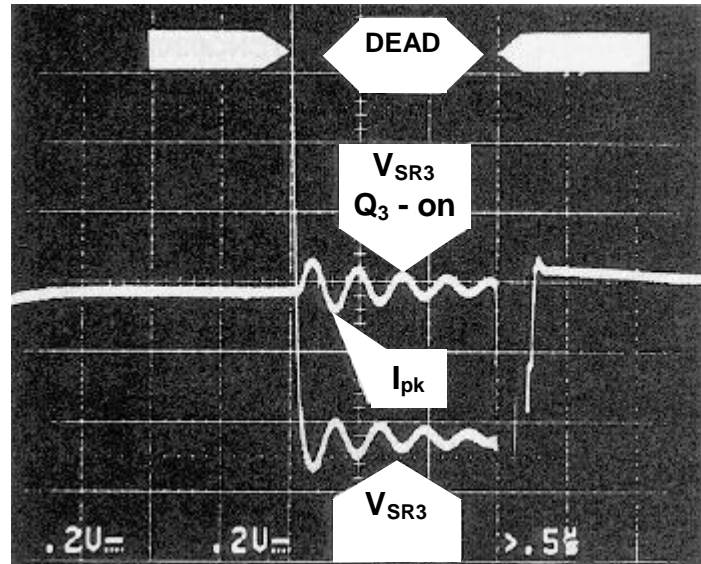

Figure 2.10. Blown-up voltage waveforms from Fig. 2.9 during dead time. From top to bottom: SR_3 voltage V_{SR3} , and SR_2 voltage V_{SR2} . Scale: $V_{SR3} = 200$ mV/div.; $V_{SR2} = 200$ mV/div. Time = $0.7 \mu\text{s}$.

in Fig. 2.10, the peak of the SR_3 current during the dead time is $I_{pk}^{SR_3} \approx 25$ A, while the peak-to-peak resonant (ringing) current amplitude (oscillatory component of the SR_3 current) is $I_r^{SR_3} \approx 12$ A. This relatively large parasitic, ringing current that circulates in the loop consisting of the secondary winding, D_2 , and Q_3 causes an additional power loss which is not taken into account in Eq. (2-11). The amount of this additional power loss depends mainly on the on-resistance of SR_3 , secondary winding resistance (at the ringing frequency) and the rms value of the ringing current. It should be noted that the power loss of the ringing current on diode D_2 of SR_2 is relatively small because the dynamic resistance of diode D_2 is much smaller than the on-resistance of transistor Q_3 . That is the reason that, although the parasitic oscillations are also present in the converter with self-driven SRs (see Fig. 2.3), they do not significantly affect the efficiency. Namely, in the self-driven implementation, both diodes D_2 and D_3 are conduction during the dead time.

The effect of the above described circulating ringing current is to decrease the efficiency of the converter. Its effect is more pronounced at higher line voltages where the dead-time duration is longer. As a result, the efficiency of the converter with control-driven SRs shows a relatively steep fall-off as the input voltage increases compared with the converter with self-driven SRs.

Figure 2.8 also shows the calculated efficiency curve that takes into account the effect of secondary-side circulating ringing current during the dead time. The modified expression that is used to calculate this curve is

$$\frac{I}{h_{SR}^{cd}} = \frac{I}{h_{SH}} - \frac{V_{SH}}{V_o} \left[I - \frac{R_{DS(on)} I_o}{V_{SH}} (1 - D_{dead}) - \frac{R_{loop} [(I_o - I_m^-)^2 + I_r^2 / 2]}{V_{SH}} (D_{dead} - D_{delay}) \right. \\ \left. - \frac{V_D}{V_{SH}} \frac{I_m^-}{I_o} D_{dead} - \frac{V_D}{V_{SH}} \left(1 - \frac{I_m^-}{I_o} \right) D_{delay} \right] \quad (2-13)$$

where R_{loop} is the total resistance of the secondary-side loop consisting of the secondary winding, SR_2 , and SR_3 . Practically, this resistance is the sum of the secondary winding resistance at the ringing frequency and the on-resistance of SR_3 .

As can be seen from Fig. 2.8, although Eq. (2-13) gives better agreement between the calculated and measured curves (maximum difference reduced to 1.6%), a significant discrepancy between these two curves is still present. While 0.6%-0.7% of this discrepancy can be attributed to the reverse-recovery loss, as in the case of the self-driven converters, the remaining difference can only be explained by the inaccuracy in determining the magnitude of the ringing current. Namely, it is not possible to measure this current directly because any current-measuring device (including a transformer probe) was found to significantly disturb the operation of the circuit by introducing a relatively significant inductance in the secondary side loop. As a result, the ringing current must be measured indirectly (e.g., measuring the voltage waveform across SR_3 using a scope), and then estimated from the measurement, which inadvertently introduces an error.

Finally, Fig. 2.11 show the measured efficiency of the experimental forward converter with RCD-clamp reset and control-driven SRs for different delay times between the SRs gate-drive signals. As can be seen, the efficiency is very sensitive to the duration of the delay time. It

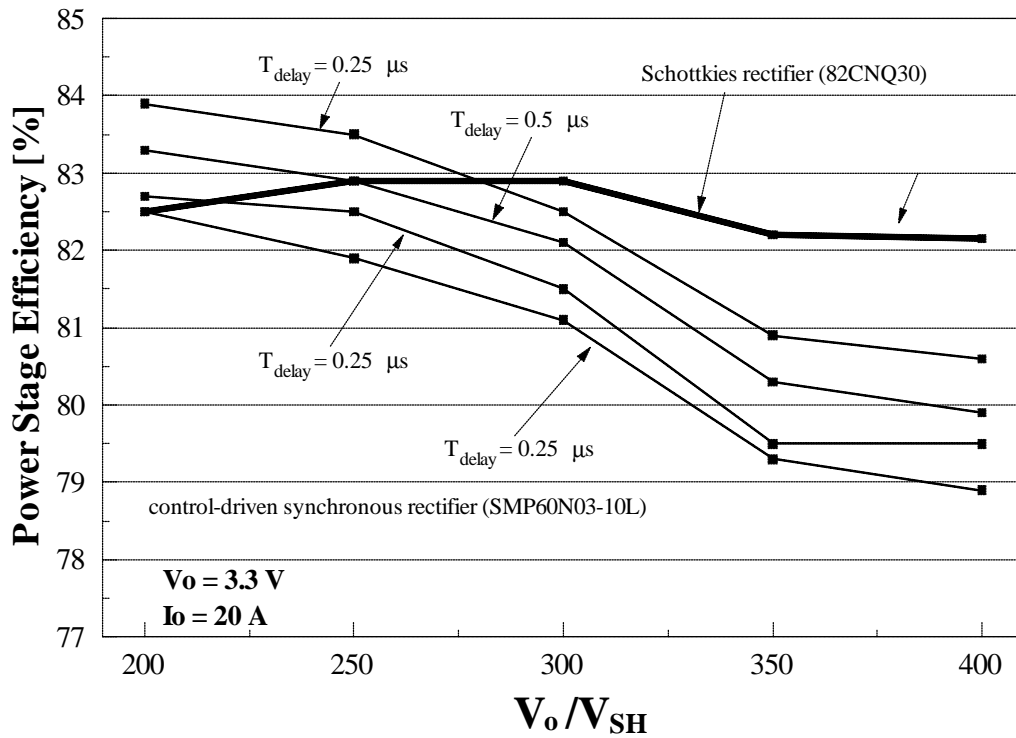

Figure 2.11. Measured efficiencies of forward converter power stage with RCD-clamp reset and control-driven SRs with different delay times.

decreases as the delay time, T_{delay} , increases. In fact, for longer delay time, the efficiency improvement at lower input voltage also decreases.

2.1.4. Summary

Different implementations of synchronous rectification in the forward-converter topology are discussed, and the effect of the transformer resetting mechanism on the performance of the self-driven synchronous-rectifiers (SRs) is analyzed. An estimate of the upper limit of the efficiency improvement of synchronous rectification relative to the Schottky diode implementation is derived, as shown in Figs. 2.5 and 2.6. The limit is a function of the output voltage, output current, on-resistance of SRs, forward-voltage drop of Schottkies that are being replaced with SRs, efficiency of the converter with Schottkies, and SR implementation. These figures can be used for general applications to determine the efficiency improvement of employing synchronous rectifiers in forward converters to replace conventional diode rectifiers once the diode efficiency is provided or estimated. The discussed SR implementations are evaluated experimentally on a 3.3-V/20-A, off-line power state. The achieved efficiency improvements for this application were, as predicted, relatively modest (1-2%).

2.2. Synchronous Rectification in Flyback Converter

A number of applications of the SR in the flyback converter have also been reported [A23-A25]. However, in all of these applications, the main purpose of the SR was to provide the post-regulation of the output voltage and not to maximize the conversion efficiency. Specifically, in [A23-A25], the SR is used as a voltage-controlled resistor in a control loop which adjusts the SRs resistance so that the output voltage is maintained within the regulation range, as shown in Fig. 2.12. Generally, the regulation range of these post-regulation approaches is limited to the forward-voltage drop of the SR body diode, i.e., ~ 0.7 V. Moreover, since the voltage drop across the SR is not minimized because of the resistance modulation, the conversion efficiency of these post regulators is reduced, compared to that of the converter with the “true” SR.

This section evaluates the theoretical and practical limits of the efficiency improvements for various implementations of the flyback converter with the SR with respect to the corresponding converter with the diode rectifier. Specifically, the design considerations and performance evaluations of the constant-frequency (CF) continuous-conduction-mode (CCM), CF discontinuous-conduction-mode (DCM), variable-frequency (VF) DCM, and zero-voltage-switched (ZVS) DCM flyback converters with SR are discussed. The experimental verification was implemented for an off-line, universal-input, 15-V/36-W flyback adapter application.

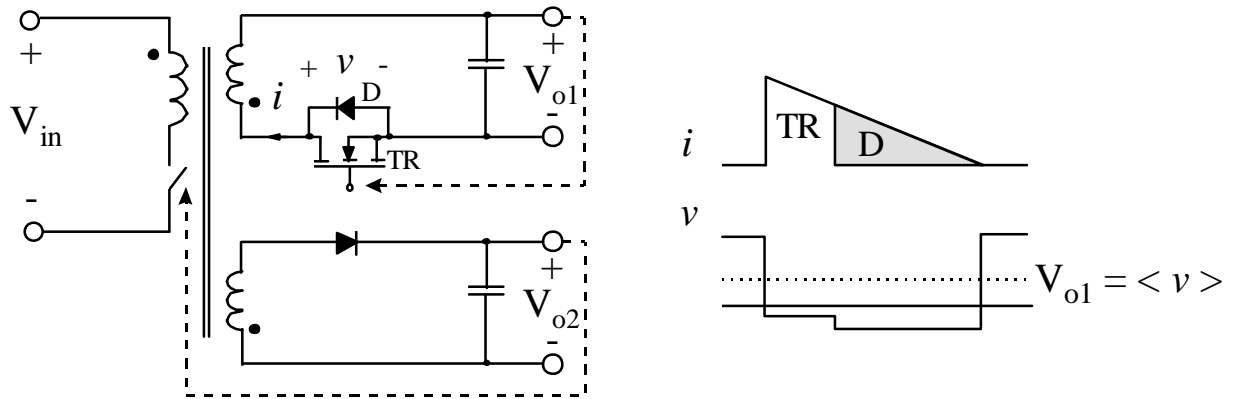

Figure 2.12. Synchronous rectifier in flyback converter used as post regulator in multiple-output applications.

2.2.1. Synchronous Rectifier Implementations

A flyback converter with the SR is shown in Fig. 2.13. For proper operation of the converter, conduction periods of primary switch SW and secondary-side switch SR must not overlap. To avoid the simultaneous conduction of the SW and the SR , a delay between the turn-off instant of switch SW and the turn-on instant of the SR as well as between the turn-on instant of the SW and turn-off instant of the SR must be introduced in the gate-drive waveforms of the switches. With properly designed gate drives, the operation of the circuit shown in Fig. 2.13 is identical to that with a conventional diode rectifier. Namely, during the time switch SW is turned on, energy is stored in the transformer magnetizing inductance and transferred to the output after SW is turned off.

Generally, the circuit shown in Fig. 2.13 can work in CCM or DCM either with a constant or variable switching frequency PWM control. Design considerations and SR loss estimates for various modes of operation and different control approaches are given next.

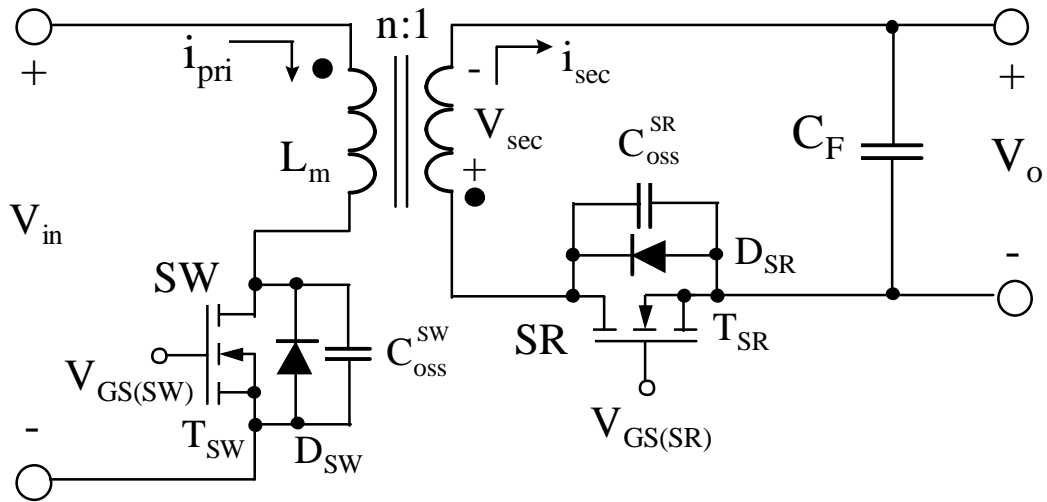

Figure 2.13. Flyback converter with synchronous rectifier.

A. Constant-Frequency (CF) Continuous-Conduction-Mode (CCM)

The key waveforms of the flyback converter with the SR operating in CCM are given in Fig. 2.14. As can be seen from Fig. 2.14, during delay times T_D^{on} and T_D^{off} , secondary current i_{sec} flows through the body diode of the SR. The conduction of body diode D_{SR} not only increases the conduction loss, but also introduces a reverse-recovery loss when primary switch SW is turned on. The conduction loss of the SR is given by the sum of the channel-resistance loss and body-diode loss as

$$P_{cond}^{SR} = R_{DS(on)} \left[\frac{I_o^2}{1-D} + \frac{DI_{sec}^2(1-D)}{12} \right] + V_D I_D (T_D^{on} + T_D^{off}) f_s \quad (2-14)$$

where $R_{DS(on)}$ is the SR on-resistance, $D = T_{on}/T_s$ is the duty-ratio of the primary switch SW , I_o is the output current, DI_{sec} is the secondary peak-to-peak ripple current, V_D and I_D are the forward-voltage drop and current of the body diode, respectively.

The reverse-recovery loss of the SR body diode is given by

$$P_{RR}^{SR} = Q_{RR} \left(V_o + \frac{V_{in}}{n} \right) f_s \quad (2-15)$$

where Q_{RR} is the recovered charge of the SR body diode, and $V_o + V_{in}/n$ is the steady-state reverse voltage across the SR.

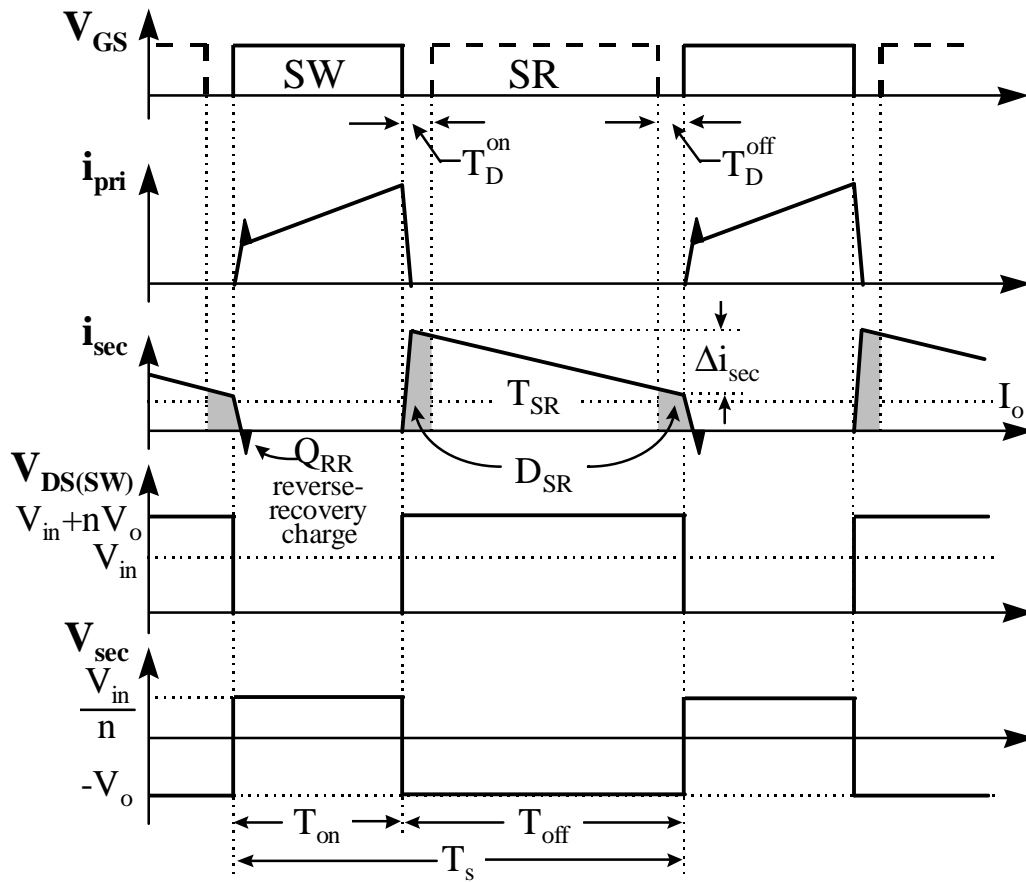

Figure 2.14. Key waveforms of CF CCM flyback converter with SR. Body diode of SR conducts in shaded area (■).

In addition to P_{cond}^{SR} and P_{RR}^{SR} losses, the CF CCM converter in Fig. 2.13 exhibits a loss each time the SR is turned off (i.e., each time the SW is turned on) because of a parasitic resonance between C_{oss}^{SR} and the leakage inductance of the transformer (see Fig. 2.21). Since the parasitic resonance must be damped by a snubber to limit the maximum voltage across the SR, the resonance dies out completely before SR is turned on again. As a result, the power loss due to this parasitic resonance can be calculated from

$$P_{off}^{SR} = \frac{1}{2} C_{oss}^{SR} \left(V_o + \frac{V_{in}}{n} \right)^2 f_s. \quad (2-16)$$

Finally, for proper operation of the circuit, the SR must be turned off before primary switch SW is turned on (delay time T_D^{off} in Fig. 2.14). Therefore, the flyback converter with the SR cannot be self-driven from the secondary winding of the transformer. In fact, the circuit shown in Fig. 2.13 requires an external control circuit to turn off the SR.

B. CF Discontinuous-Conduction-Mode (DCM)

The key waveforms of the constant-frequency flyback converter with the SR operating in DCM are shown in Fig. 2.15. In DCM, the energy stored in the magnetizing inductance of the transformer during the on time of switch SW is completely discharged during the subsequent off time. As can be seen from Fig. 2.15, secondary current i_{sec} reaches zero before primary switch SW is turned on. To prevent the discharging of the output filter capacitor through a conducting SR, the SR channel conduction (transistor T_{SR}) must be terminated at the moment i_{sec} reaches zero, or

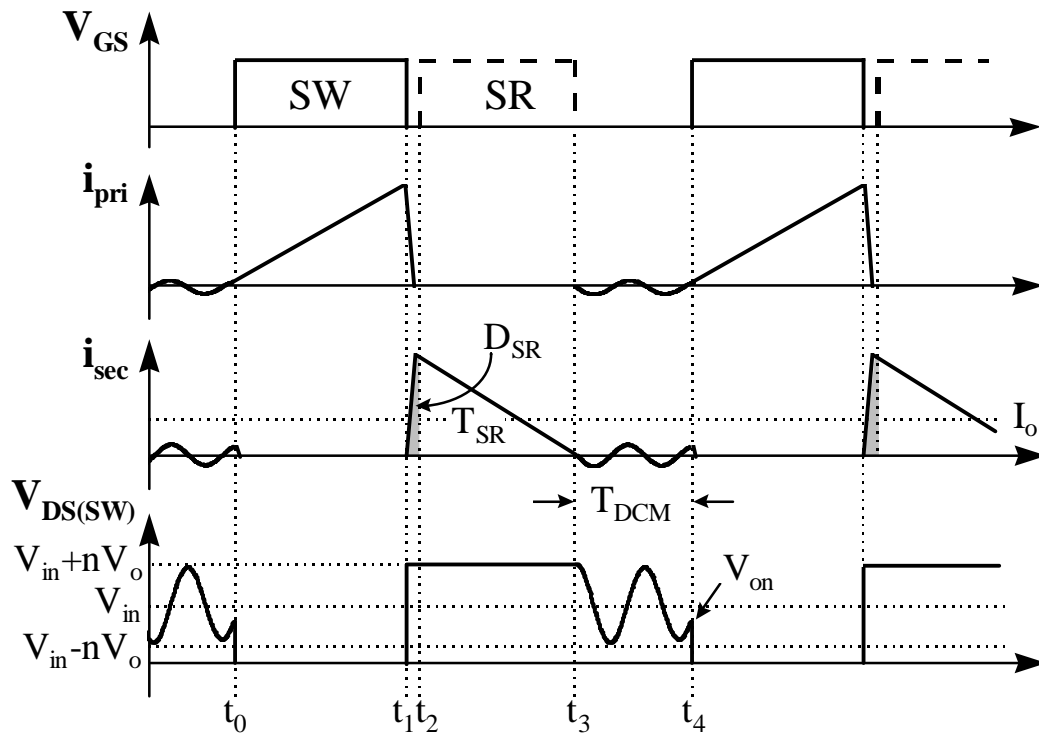

Figure 2.15. Key waveforms of CF DCM flyback converter with SR. Body diode of SR conducts in shaded area (■).

a short while after. Therefore, the DCM flyback converter with the SR requires a zero-current-crossing detector in the control circuit.

After the SR is turned off, the magnetizing inductance of the transformer L_m and capacitance $C_{eq} = C_{oss}^{SW} + C_{oss}^{SR} / n^2$ starts resonating, as shown in Fig. 2.15. For a converter with a regulated output, the duration of resonant interval T_{DCM} in Fig. 2.15 changes significantly with the input voltage and less dramatically with the output current. As a result, the voltage across the primary switch at the moment of its turn on can range anywhere between $V_{in} + nV_o$ and $V_{in} - nV_o$, producing the capacitive turn-on loss of

$$P_{cap(SW)} = \frac{1}{2} C_{oss}^{SW} V_{on}^2 f_s \quad (2-17)$$

where $V_{in} - nV_o \leq V_{on} \leq V_{in} + nV_o$. Since $P_{cap(SW)}$ is maximum at the peaks of the $V_{DS(SW)}$ oscillation and minimum at its valleys, the efficiency of the converter has strong fluctuations with the input voltage. In addition, because typical SRs have a much larger output capacitance C_{oss}^{SR} than the Schottky rectifiers, the characteristic impedance, $Z_m = \sqrt{L_m / C_{eq}}$, of the resonant tank consisting of L_m and C_{eq} , is much lower for the converter with an SR compared to that with a Schottky diode. As a result, the resonant-tank current of the converter with an SR is much higher than that of the converter with a Schottky, causing a larger conduction loss. For certain line and load conditions, this power loss can completely offset the conduction power-loss savings obtained by the SR, making the efficiency of the converter with the SR lower than that of the converter with the diode rectifier.

Finally, it should be noted that in the DCM flyback converter reverse-rectifier loss P_{RR}^{SR} is eliminated because the rectifier current becomes zero before primary switch SW is turned on.

C. Variable-Frequency (VF) DCM

Capacitive switching loss $P_{cap(SW)}$ can be minimized, and parasitic oscillation caused by the interaction between L_m and C_{eq} can be eliminated if the primary switch SW is turned on at the moment $V_{DS(SW)}$ reaches its minimum voltage, $V_{in} - nV_o$, the first time after the SR is turned off, as shown in Fig. 2.16. This can be accomplished by sensing the zero-current-crossing of i_{sec} and turning on SW after a constant delay T_{delay} which is equal to one half of the parasitic-resonance period, i.e.,

$$T_{delay} = \mathbf{p} \sqrt{L_m C_{eq}} . \quad (2-18)$$

With this variable-frequency control, the efficiency fluctuations with the input voltage are eliminated. It should be noted that with the VF control, the switching frequency is minimum at low line and full load, and it increases as the line increases and/or load decreases.

The conversion efficiency at low line of the variable-frequency DCM converter can be always made higher than the efficiency of the corresponding constant-frequency counterpart. In addition, the high-line efficiency of the VF DCM converter can also be higher than that of the CF DCM implementation if the power-loss savings due to the elimination of the parasitic oscillations and the minimization of the turn-on voltage V_{on} are higher than the increased switching losses and magnetic losses due to the increased switching frequency.

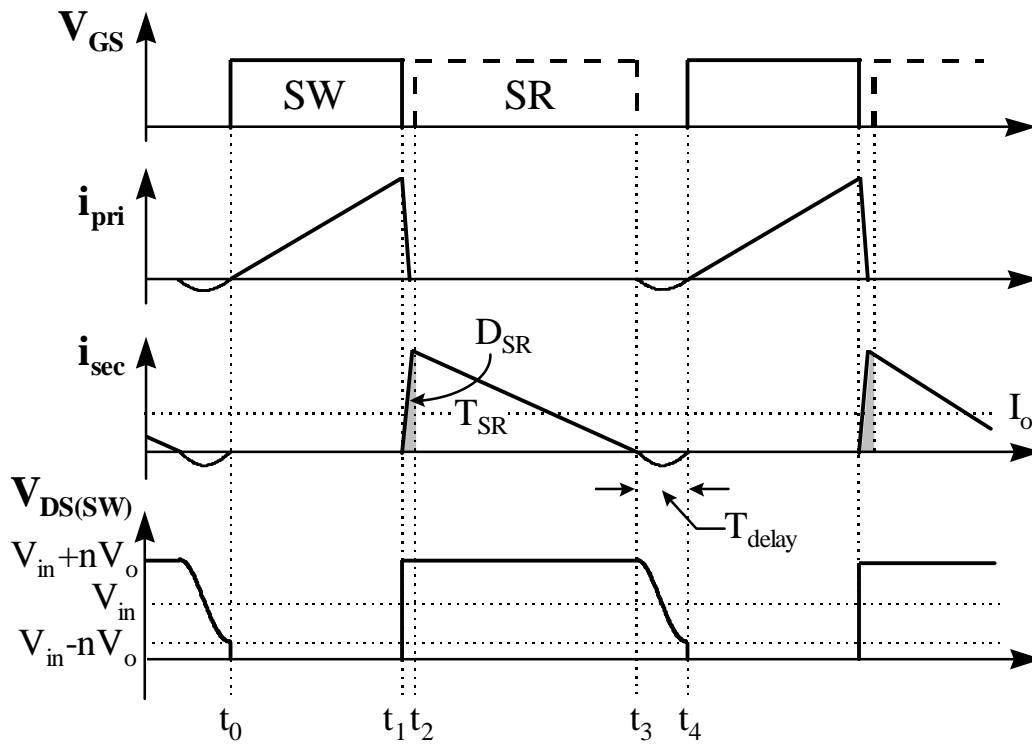

Figure 2.16. Key waveforms of VF DCM flyback converter with SR. Body diode of SR conducts in shaded area (■).

D. VF Zero-Voltage-Switched (ZVS) DCM

As can be seen from Fig. 2.16, if the amplitude of the oscillation after the turn-off of the SR is larger than the input voltage, i.e., if

$$V_{in} < nV_o, \quad (2-19)$$

primary-switch voltage $V_{DS(SW)}$ will fall to zero before the switch is turned on at the moment $t_4 = t_3 + T_{delay}$ [A26, A27]. Therefore, for $V_{in} < nV_o$, the VF flyback converter can achieve ZVS, i.e., the capacitive turn-on loss of the primary switch can be eliminated. While the ZVS condition in Eq. (2-19) may be met for certain designs at low input-voltages, generally it is not met at higher input voltages. As a result, at higher input voltages, the VF flyback converter with gate-drive timing given in Fig. 2.16 operates with partial ZVS.

However, the complete ZVS of the primary switch in the VF flyback converter with the SR can be achieved in the entire input-voltage range if the turn-off instant of the SR after the secondary current zero-crossing is delayed enough to allow a negative secondary current to build up, as shown in Fig. 2.17. To achieve ZVS in the entire input-voltage range, the energy stored in magnetizing inductance L_m by the negative secondary current I_{ZVS} must be large enough to discharge primary switch capacitance C_{oss}^{SW} from voltage $V_{in} + nV_o$ down to zero, i.e.,

$$I_{ZVS} \geq \frac{n\sqrt{V_{in(max)}^2 - (nV_o)^2}}{Z_m}. \quad (2-20)$$

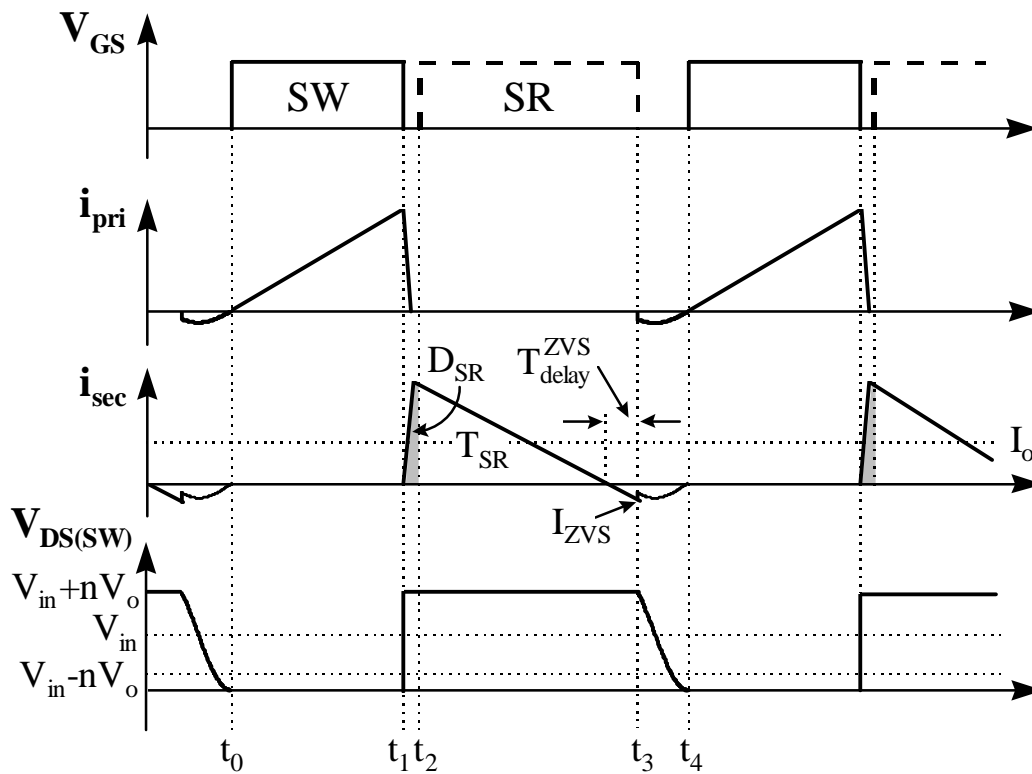

Figure 2.17. Key waveforms of VF ZVS DCM flyback converter with SR. Body diode of SR conducts in shaded area (■).

Therefore, to build up the necessary I_{ZVS} , the turn-off of the SR should be delayed after the zero-crossing of i_{sec} for

$$T_{delay}^{ZVS} = \frac{L_m \cdot I_{ZVS}}{n^2 \cdot V_o}, \quad (2-21)$$

as shown in Fig. 2.17.

Finally, it should be noted that in VF ZVS DCM flyback converter with the SR the capacitive turn-on switching loss of the primary switch is traded off for the conduction loss. Namely, according to Fig. 2.17, due to the negative secondary current, the RMS value of the secondary current is slightly increased. Therefore, the VF ZVS converter in Fig. 2.17 might not necessarily achieve higher efficiency compared to the VF converter with partial ZVS (Fig. 2.16).

2.2.2. Efficiency Limit of Synchronous Rectification

Generally, in a flyback converter, the substitution of the diode rectifier with an SR affects the conduction and switching losses of the rectifier. In addition, the employment of an SR allows for the implementation of VF flyback converter with complete ZVS, i.e., without any primary-switch capacitive turn-on switching loss $P_{cap(SW)}$. Table 2-I summarizes theoretical rectifier conduction loss P_{cond} , rectifier switching losses, $P_{sw} = P_{off} + P_{RR}$, and the primary switching loss, $P_{cap(SW)}$, of the flyback converter with diode rectifier (DR) and the SR.

The efficiency of a converter with the diode rectifier can be expressed as

TABLE 2-1.

POWER LOSS COMPARISONS OF FLYBACK CONVERTERS WITH DIODE RECTIFIER (DR) AND SYNCHRONOUS RECTIFIER (SR).

| | CF CCM | CF DCM | VF DCM | VF ZVS DCM |
|---------------|---|---------------------------------------|--|--|
| DR | $V_F I_o$ | $V_F I_o$ | $V_F I_o$ | not possible to implement |
| | $R_{DS(on)} \left[\frac{I_o^2}{1-D} + \frac{DI_{sec}^2(1-D)}{I2} \right] + V_D I_D (T_D^{on} + T_D^{off}) f_s$ | $R_{DS(on)} \frac{4I_o^2}{3(1-D)}$ | $R_{DS(on)} \frac{4I_o^2}{3(1-D)}$ | $R_{DS(on)} \frac{4I_o^2}{3(1-D)} + \frac{I_{ZVS} 2I_o + I_{ZVS}(1-D)}{3}$ |
| SR* | $\left[\frac{C_T}{2} \left(V_o + \frac{V_{in}}{n} \right)^2 + Q_{RR}^{DR} \left(V_o + \frac{V_{in}}{n} \right) \right] f_s$ | 0 | 0 | not possible to implement |
| | $\left[\frac{C_{oss}^{SR}}{2} \left(V_o + \frac{V_{in}}{n} \right)^2 + Q_{RR}^{SR} \left(V_o + \frac{V_{in}}{n} \right) \right] f_s$ | 0 | 0 | 0 |
| $P_{cap(SW)}$ | $\frac{C_{oss}^{SW}}{2} (V_{in} + nV_o)^2 f_s$ | $\frac{C_{oss}^{SW}}{2} V_{on}^2 f_s$ | $\frac{C_{oss}^{SW}}{2} (V_{in} - nV_o)^2 f_s$ | not possible to implement |
| | $\frac{C_{oss}^{SW}}{2} (V_{in} + nV_o)^2 f_s$ | $\frac{C_{oss}^{SW}}{2} V_{on}^2 f_s$ | $\frac{C_{oss}^{SW}}{2} (V_{in} - nV_o)^2 f_s$ | 0 |

* Note that for Schottky rectifiers, $Q_{RR} \approx 0$.

$$\mathbf{h}_{DR} = \frac{P_o}{P_o + P_{cond}^{DR} + P_{sw}^{DR} + P_{cap(SW)}^{DR} + P_{other}} \quad (2-22)$$

where P_o is the output power and P_{other} is the loss other than the conduction and switching losses of the rectifier, and the capacitive turn-on switching loss of the primary switch.

Similarly, the efficiency of the flyback converter with the SR can be written as

$$\mathbf{h}_{SR} = \frac{P_o}{P_o + P_{cond}^{SR} + P_{sw}^{SR} + P_{cap(SW)}^{SR} + P_{other}}. \quad (2-23)$$

By eliminating P_{other} from Eqs. (2-22) and (2-23), the efficiency difference between the SR and the diode rectifier implementations can be calculated as

$$\mathbf{Dh} = \mathbf{h}_{SR} - \mathbf{h}_{DR} = \frac{\mathbf{DP}_{REC} \mathbf{h}_{DR}^2}{P_o - \mathbf{DP}_{REC} \mathbf{h}_{DR}} \quad (2-24)$$

where

$$\mathbf{DP}_{REC} = (P_{cond}^{DR} - P_{cond}^{SR}) + (P_{sw}^{DR} - P_{sw}^{SR}) + (P_{cap(SW)}^{DR} - P_{cap(SW)}^{SR}). \quad (2-25)$$

Using the power loss expressions from Table 2-I and knowing the device characteristics and the circuit parameters, the efficiency improvement of the flyback converter with the SR can be calculated. As an example, Fig. 2.18 presents the calculated efficiencies for the discussed four implementations of the converter with the SR as functions of the load current. In Fig. 2.18, it is

assumed that the diode rectifier versions of the converter have conversion efficiencies of 89%, which correspond to the efficiencies of the experimental circuit discussed in the next section.

As can be seen from Fig. 2.18, the efficiency of the ZVS DCM implementation (solid line) is highest at low power levels (i.e., for $I_o \leq 5-6$ A) because the switching turn-on loss of the primary switch contributes significantly to the total loss in the other implementations. For the same range of the output power, the CF CCM implementation exhibits the lowest efficiency due to the dominant effect of the turn-on switching loss of the primary switch and the turn-off switching loss of the SR. For example, at $I_o = 2.4$ A (which corresponds to the full-load current of the experimental converter presented in the next section), the efficiency of the ZVS DCM implementation with the SR is approximately 3% higher than the efficiency of the corresponding circuit with the Schottky rectifier. However, at $I_o = 2.4$ A, the efficiency of the CCM implementation with the SR at $I_o = 2.4$ A is 1% lower than the efficiency of the same circuit with the Schottky rectifier.

At higher power levels, the conduction losses of the primary switch and the SR start dominating the total loss. As a result, the CF CCM implementation exhibits the highest efficiency at $I_o > 15$ A due to its smallest primary and secondary RMS currents. On the other hand, the efficiency of the CF DCM implementation monolithically decreases as the load current (output power) increases. In fact, as can be seen from Fig. 2.18, for $I_o > 10$ A the efficiency of the CF DCM implementation is lower than that of the Schottky implementation. Also, as the load current, and therefore the conduction losses, become larger, the efficiencies of the VF DCM and ZVS DCM implementations converge because the power savings brought about by soft-switching in ZVS DCM implementation are less significant.

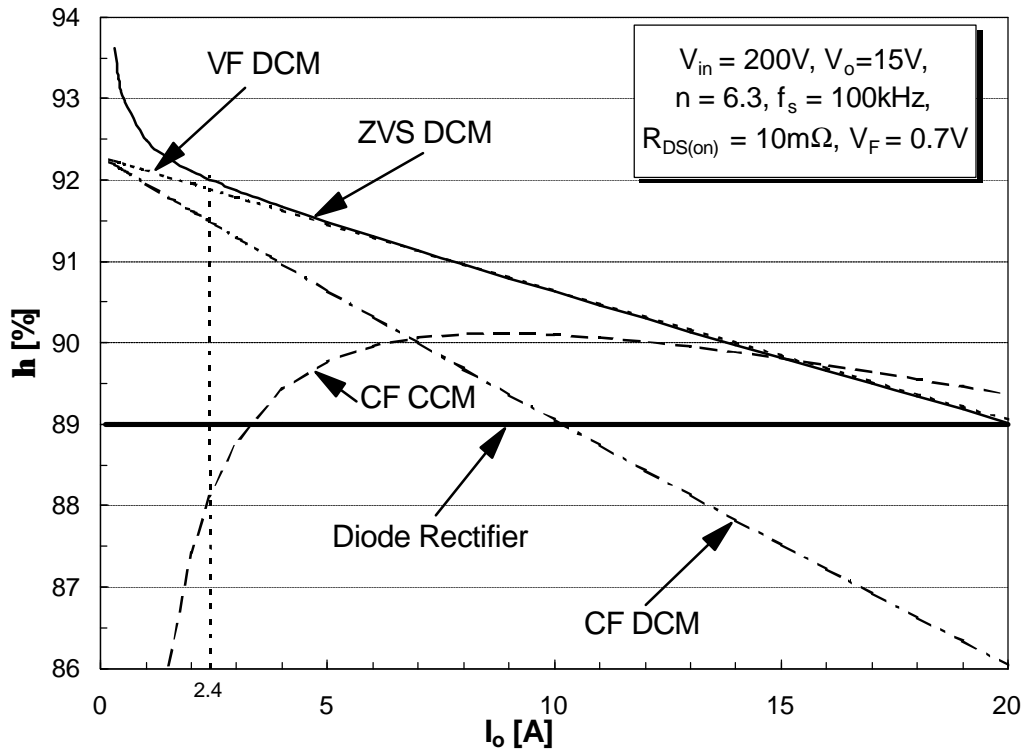

Figure 2.18. Theoretical efficiency estimates.

Finally, as the output current continues to increase, so that the voltage drop across the SR, $R_{DS(on)} \cdot i_{RMS}$, approaches that of the Schottky rectifier V_F , the efficiencies of the CF CCM, VF DCM, and ZVS DCM implementations approach that of the Schottky-rectifier implementation. As can be seen from Fig. 2.18, at $I_o = 20$ A the efficiencies of the VF DCM and ZVS DCM implementations fall to the level of the Schottky implementation efficiency. The CF CCM implementation efficiency drops to that of the Schottky-rectifier implementation at $I_o > 20$ A due to lower i_{sec}^{RMS} . The only way to achieve efficiency improvements at higher load currents i.e., when $R_{DS(on)} \cdot i_{RMS} \approx V_F$, is to resort to paralleling of SRs in order to reduce the effective $R_{DS(on)}$.

2.2.3. Evaluation Results

The discussed SR implementations were experimentally evaluated on a 15-V/2.4-A flyback converter designed to operate in the 100-370 Vdc input-voltage range. The diode-version power stages were implemented with Motorola MTP6N60 ($V_{RRM} = 600$ V, $R_{DS(on)} = 1.2 \Omega @ T_j = 25^\circ\text{C}$, $C_{oss} = 350$ pF @ $V_{DS} = 25$ V) MOSFETs for the primary switches and two IR 10CQT150 ($V_{RRM} = 150$ V, $V_F = 0.73$ V @ 5 A_{PK}, $T_j = 125^\circ\text{C}$, $C_T = 200$ pF @ $V_R = 25$ V) Schottky diodes in parallel for the secondary rectifiers. In implementations of the power stages with SRs, the Schottky diodes were replaced with IXYS IXFK100N10 ($V_{RRM} = 100$ V, $R_{DS(on)} = 11$ m $\Omega @ T_j = 25^\circ\text{C}$, $C_{oss} = 3300$ pF @ $V_{DS} = 25$ V, $V_{BD} = 1.1$ V) MOSFETs. The turns-ratio of the transformer for the CCM implementation was $n = 64:10$ ($L_m = 637$ μH), and the converter was operated in CCM at full-load over the entire input line range with switching frequency $f_s = 100$ kHz [E8]. The

transformer used for all other implementations (CF DCM, VF DCM, and ZVS DCM) had a turns ratio of $n = 38:6$ ($L_m = 229 \mu\text{H}$).

Figure 2.19 shows the control and drive circuit for the variable frequency DCM flyback converter implementations with the SR. As can be seen from Fig. 2.19, the converter has a detector which senses zero crossings of secondary current i_{sec} . The delay time between the zero crossing of secondary current i_{sec} and the turn-off of the SR is set by the R-C time constant of the T_{delay}^{ZVS} circuit which is connected to the output of the zero-crossing detector comparator. Resistors R_3 and R_4 are used to set the hysteresis of the zero-crossing detector. The VF control of the converter is achieved by employing the UC 3852 IC controller. Also, an R-C delay circuit is used on the primary side to set a proper delay between the turn-off of the SR and the turn-on of the primary switch.

A. CF CCM

Figure 2.20 shows the measured efficiencies of the CF CCM experimental converters with the Schottky diode and the SR. Because the SR body diode conducts current during delay times, T_D^{on} and T_D^{off} in Fig. 2.20, the rectifier turn-off loss becomes significant at high frequencies. In fact, in the experimental 100 kHz converter, the excessive rectifier turn-off loss in the SR converter exceeds the conduction loss savings. As predicted in Section III, the efficiency of the SR implementation is lower than that of the Schottky implementation, especially at high line, where the reverse-recovery loss given by Eq. (2-15) is highest.

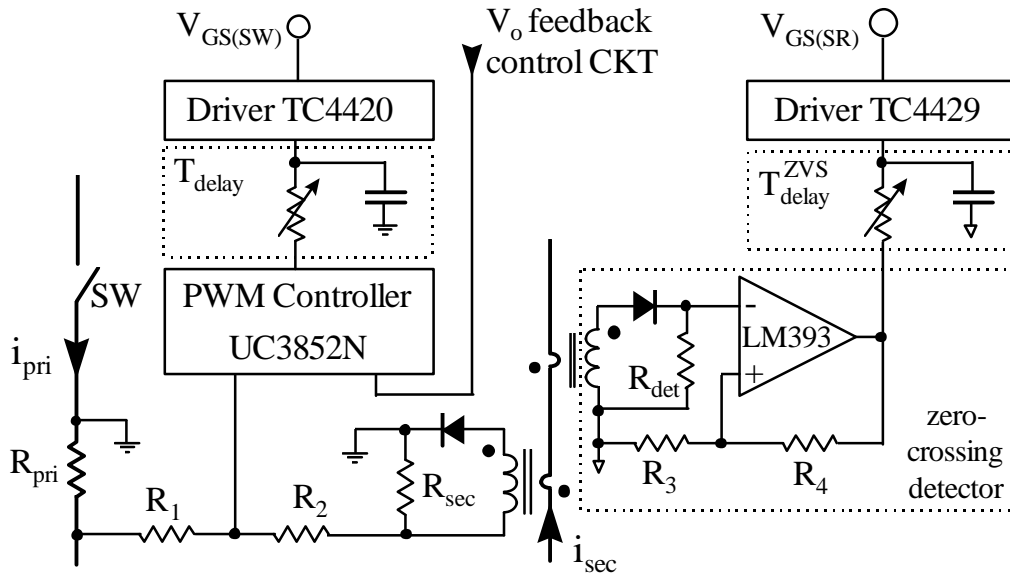

Figure 2.19. Control and drive circuit for VF DCM flyback converter with SR. The thick lines belong to power stage.

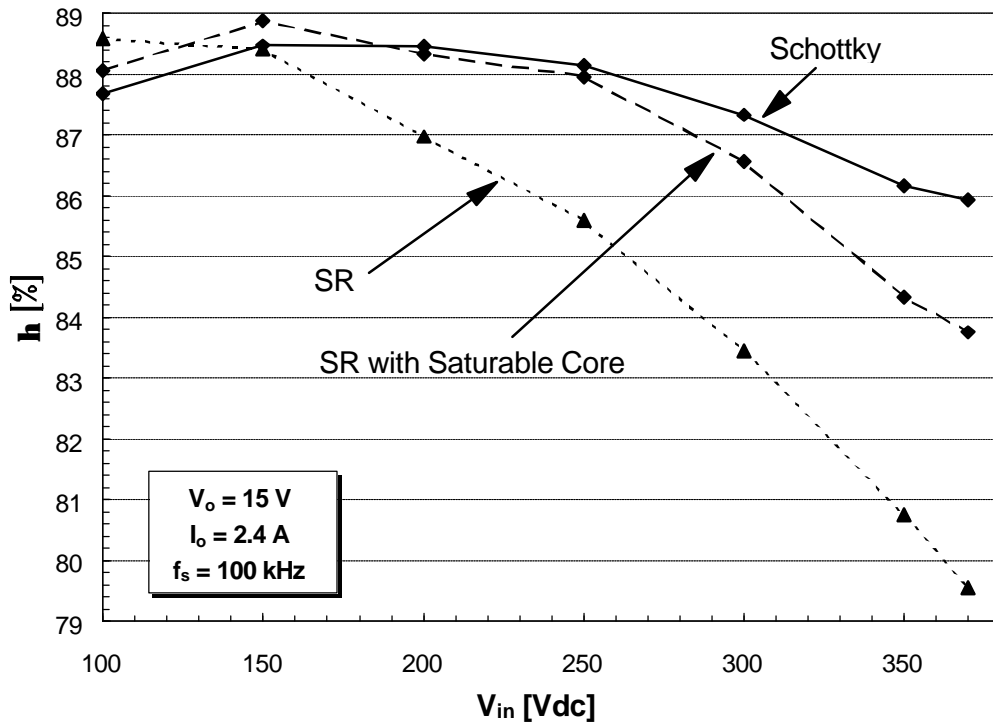
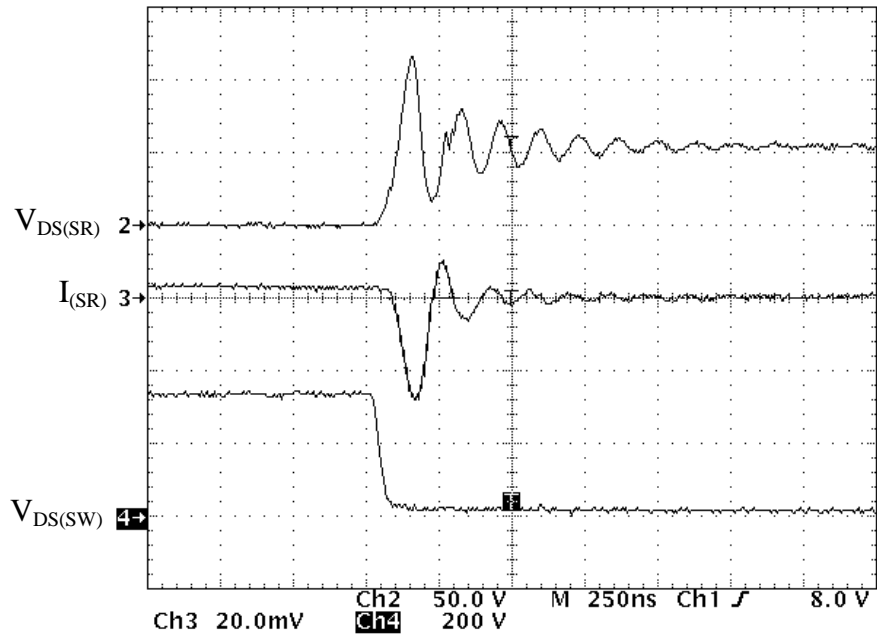
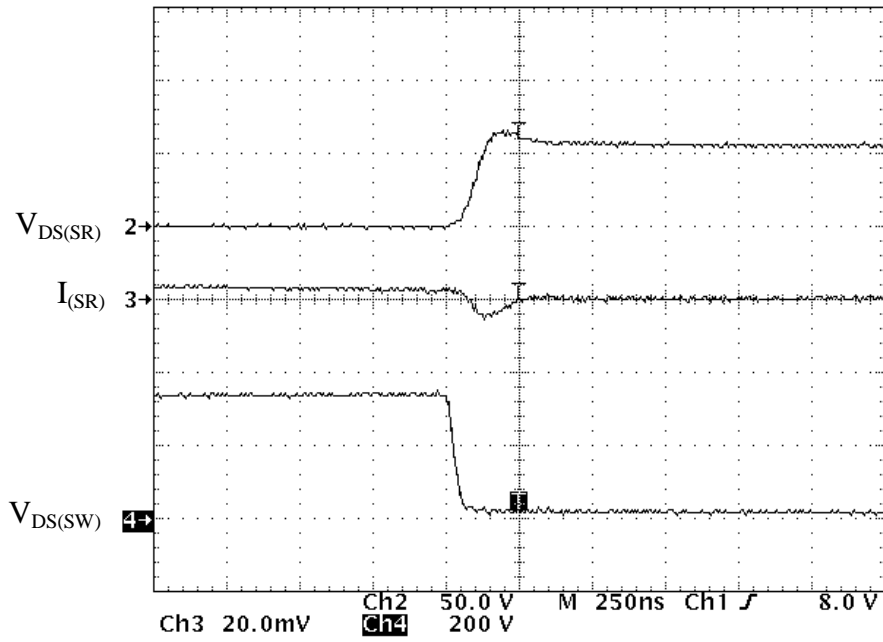

Figure 2.20. Measured efficiencies of CF CCM implementation with SR and Schottkies rectifier at full power.



(a)



(b)

Figure 2.21. SR turn-off waveforms of CF CCM converter with SR: (a) w/o saturable core; (b) w/ saturable core.

Figure 2.21(a) shows the SR turn-off waveforms which are initiated by the primary switch SW turn-on. The fast-rising voltage $V_{DS(SR)}$ causes large superimposed capacitor charging and body reverse-recovery currents. To suppress these currents, a saturable core was connected in series with the SR to slow down the rate of $V_{DS(SR)}$ rise, as shown in Fig. 2.21(b). As can be seen from Fig. 2.21(b), with the saturable-core snubber, not only the reverse current amplitude was reduced significantly, but also the rectifier voltage stress was decreased. As a result, the conversion efficiency was improved, as can be seen in Fig. 2.20. However, this approach cannot completely eliminate the body diode reverse-recovery problem. In fact, output capacitance of the SR, C_{oss}^{SR} , is significantly higher than the junction capacitance of the two paralleled Schottky diodes C_T ($C_{oss}^{SR} = 3300$ pF vs. $2C_T = 800$ pF), causing a higher capacitor charging loss according to Eq. (2-16). Therefore, at 36-W power level the CCM converter with the Schottky rectifier exhibits higher efficiency than that with the SR.

B. CF DCM

Figure 2.22 shows an oscillogram with the key waveform of the CF DCM converter with the SR. During the resonant-interval T_{DCM} , L_m - C_{eq} resonance can be clearly seen in both $I_{(SR)}$ and $V_{DS(SW)}$ waveforms. The measurement points of the efficiency plot shown in Fig. 2.23 were collected at the valleys, $V_{in} - nV_o$, and the peaks, $V_{in} + nV_o$, of $V_{DS(SW)}$. As can be seen from Fig. 2.23, the resonant peak points correspond to the lowest efficiencies, and the resonant valley points correspond to the highest efficiencies. The SR and diode rectifier implementations have peaks and valleys at different time instants within a switching period because the resonant period in the SR converter is longer due to a higher C_{oss} value. Therefore, at certain input voltages, the

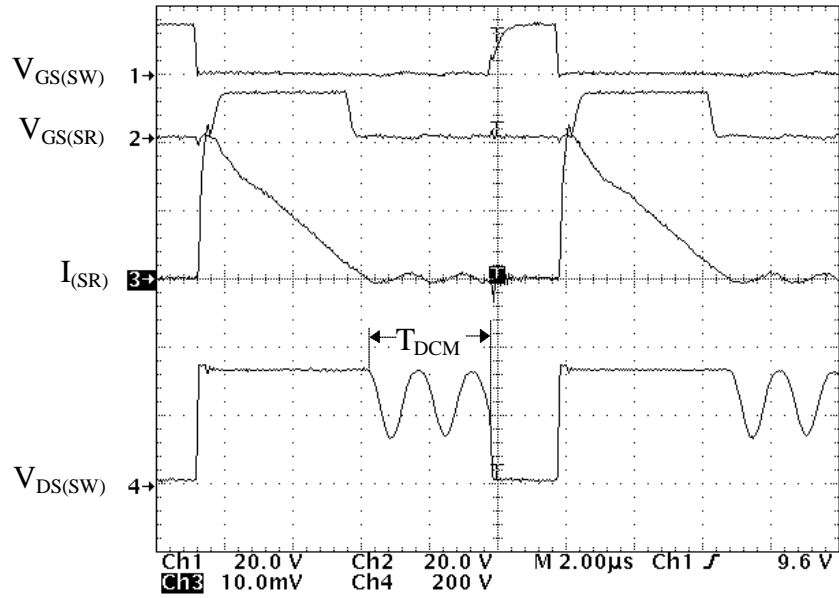

Figure 2.22. Measured waveforms of CF DCM converter with SR at $V_{in} = 250$ Vdc.

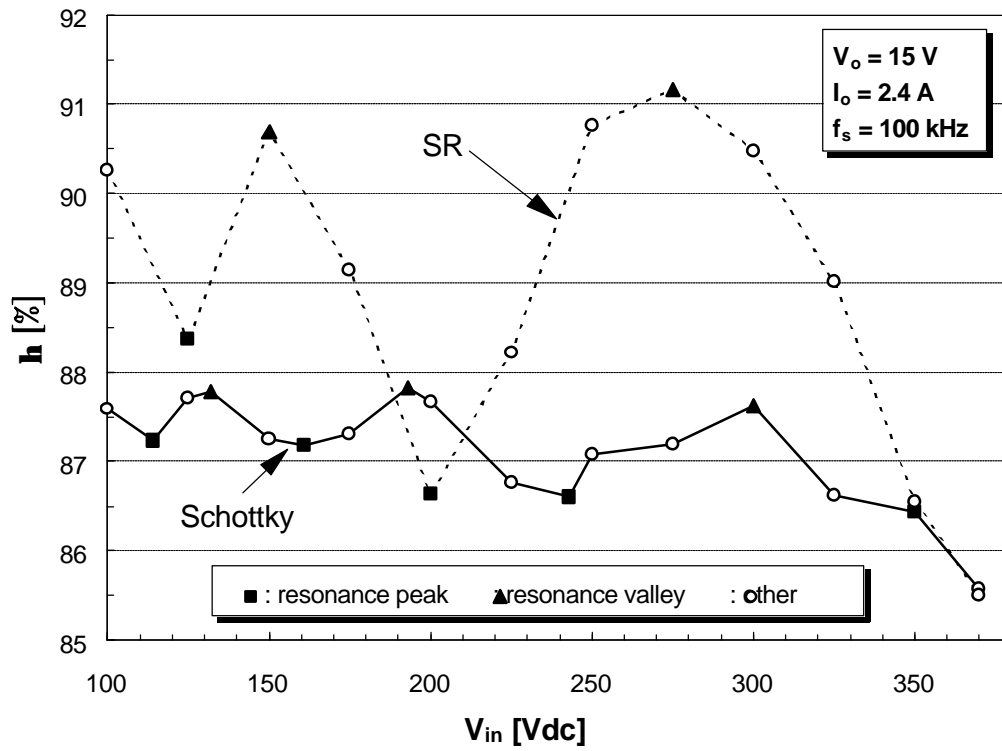

Figure 2.23. Measured efficiency of CF DCM implementation with SR and Schottky at full power.

SR efficiency is lower than that of Schottky and the efficiency improvement is not constant throughout the input range.

C. VF DCM and ZVS DCM

Figure 2.24 shows the measured waveforms of the VF DCM and ZVS DCM converters with the SR. As can be seen from Fig. 2.24(a), primary switch SW in the VF DCM implementation is turned on at a voltage lower than V_{in} . To achieve the switch turn-on with minimum voltage $V_{DS(SW)}$, the delay time between the zero-crossing instant of i_{sec} and the turn-on of the primary switch SW must be properly designed. Taking the non-linear effect of MOSFET output capacitance into consideration, the equivalent capacitance of the resonance tank L_m - C_{eq} is

$$C_{eq} = \frac{3300 p}{(38:6)^2} \cdot \sqrt{\frac{25}{V_{DS}^{SR}}} + 350 p \cdot \sqrt{\frac{25}{V_{DS}^{DR}}} \approx 106 pF . \quad (2-26)$$

Therefore, according to Eq. (2-18), the turn-on delay of VF DCM converter with the SR was adjusted to

$$T_{delay} = p \sqrt{229 m \cdot 106 p} = 0.5 ms , \quad (2-27)$$

as shown in Fig. 2.24(a).

By eliminating the parasitic resonance during the T_{DCM} interval, the efficiency of the VF DCM implementation with the Schottky rectifier is 1% higher than the efficiency of the corresponding CF DCM implementation, as can be seen comparing measurements given in Figs. 2.23 and 2.25. Furthermore, the efficiency comparisons in Fig. 2.25 shows that VF DCM

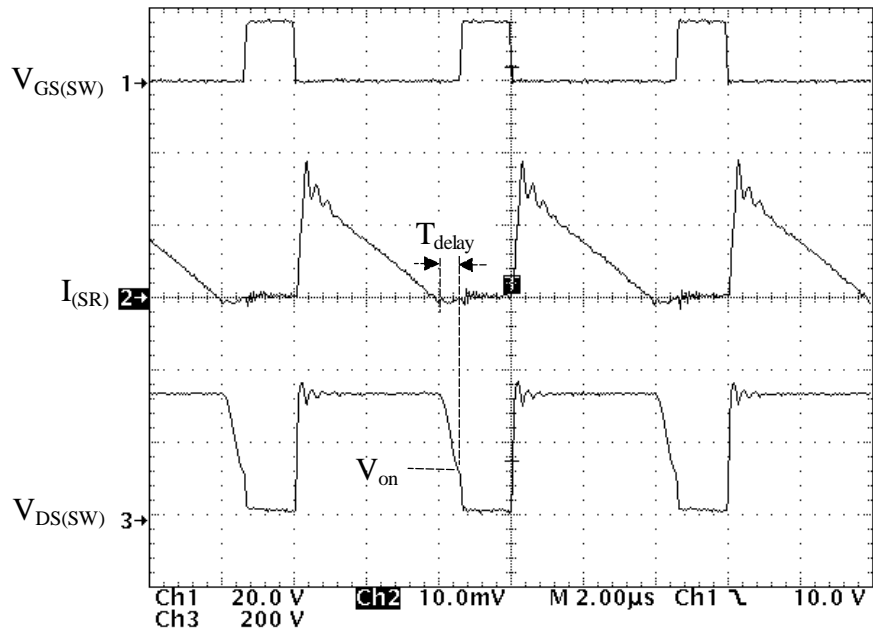

(a)

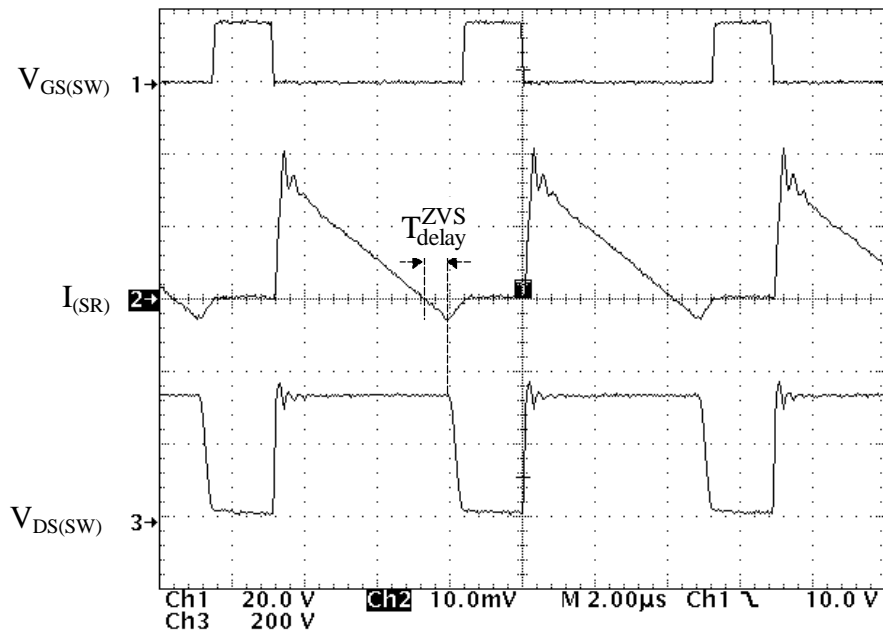

(b)

Figure 2.24. Measured waveforms at $V_{in} = 250$ Vdc, $V_o = 15$ V, $I_o = 2.4$ A: (a) VF DCM implementation with SR; (b) ZVS DCM implementation.

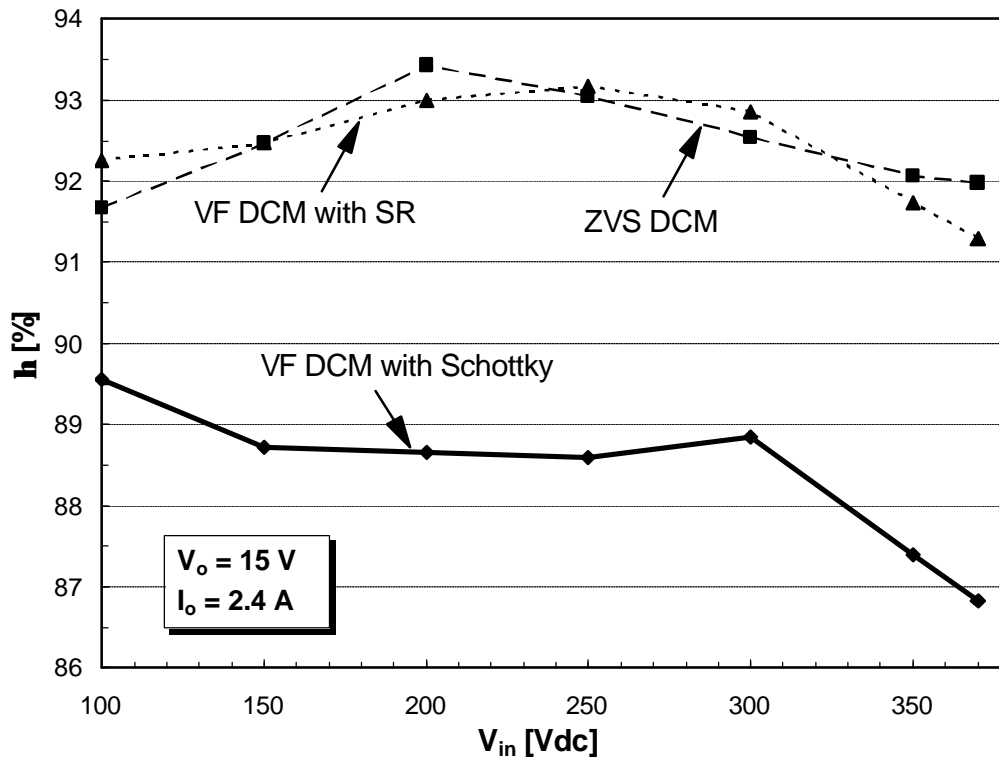

Figure 2.25. Measured efficiencies of VF DCM implementations with SR and Schottky, and ZVS-DCM implementation at full power.

implementation with the SR has a relatively constant 2.5-4% efficiency improvement over VF DCM implementation with the Schottky, as has been predicted. However, in the VF DCM implementation only partial ZVS can be achieved, since in this design, input voltage ($V_{in} = 100-370$ V) is larger than the reflected output voltage ($nV_o = 95$ V), i.e., $V_{in} > nV_o$.

Soft-switching can be obtained for the entire input line range if secondary current i_{sec} is allowed to flow in the negative direction to the level I_{ZVS} given in Eq. (2-20), i.e.,

$$I_{ZVS} = \frac{(38:6) \cdot \sqrt{370^2 - [(38:6) \cdot 15]^2}}{\sqrt{\frac{229 \text{ m}}{106 \text{ p}}}} = 1.5 \text{ A}. \quad (2-28)$$

The required delay time for the secondary current to reach I_{ZVS} is

$$T_{delay}^{ZVS} = \frac{206 \text{ m} \cdot 1.5}{(38:6)^2 \cdot 15} = 0.6 \text{ ns}, \quad (2-29)$$

as shown in Fig. 2.24(b).

The obtained efficiency of the ZVS DCM converter is very close to that of the VF DCM converter with the SR due to the increased conduction loss in the ZVS DCM converter. The switching frequencies of the three VF implementations are shown in Fig. 2.26. Because of the larger SR output capacitance and additional delay T_{delay}^{ZVS} required to obtain I_{ZVS} , VF DCM converter with the Schottky has the highest switching frequency, while ZVS DCM implementation has the lowest switching frequency. Also, the switching frequency range in ZVS DCM implementation is the smallest due to the longest delay time.

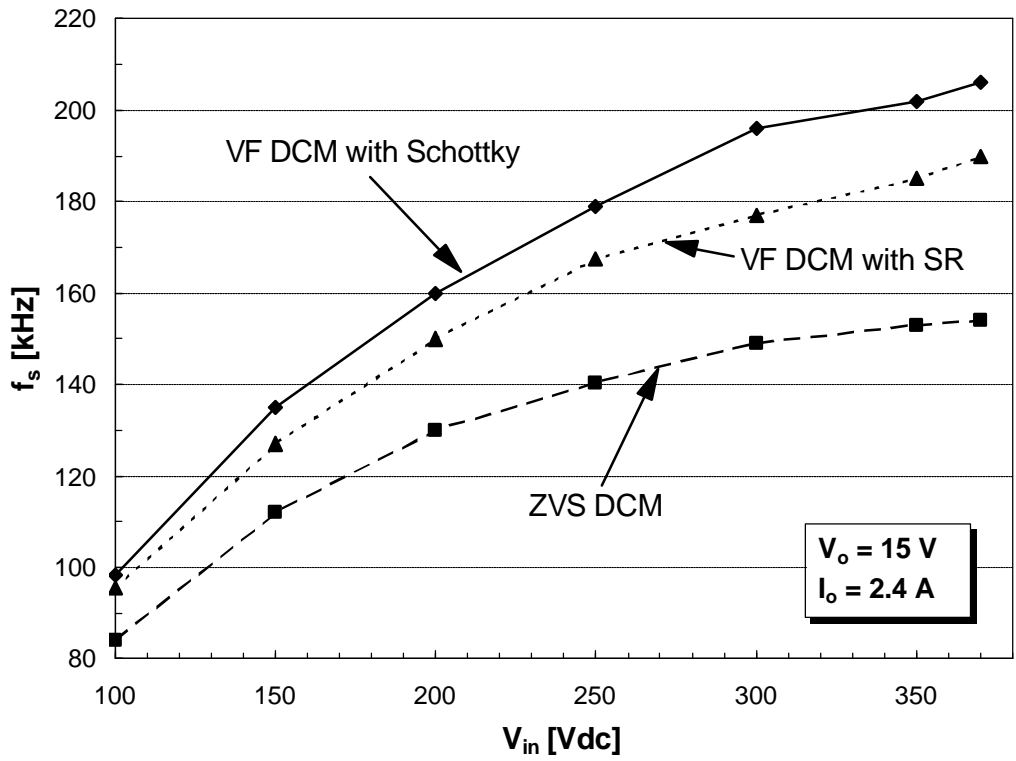

Figure 2.26. Switching frequency comparison of VF DCM implementations with SR and Schottky, and ZVS-DCM implementation.

2.3. Summary

The theoretical efficiency improvement limit of various implementations of synchronous rectification in flyback converters is presented, as shown in Fig. 2.18. However, unlike synchronous rectification in forward converter, it is difficult to normalize the efficiency improvement limit due to its complex dependence on multi-parameters. For general applications in flyback converters to determine the efficiency improvement of synchronous rectification over diode rectification, the formulae in Table 2-I, together with Eqs. (2-24) and (2-25), can be used, once the diode efficiencies are provided or estimated.

It was shown that the variable-frequency (VF) discontinuous-conduction-mode (DCM) flyback converter implementation is most suitable for synchronous rectification. Moreover, this implementation can be easily designed to work with complete or partial zero-voltage-switching of the primary switch by properly adjusting the delay time between the zero-crossing of the secondary current and the turn-off instant of the synchronous rectifier. In off-line applications, the VF DCM flyback converter with a synchronous rectifier shows a typical efficiency improvement in the 2-4% range compared to the corresponding circuit with a diode rectifier.