

## Appendix A: Carpal Wrist Prototype

The theoretical evolution of the Carpal wrist concept has resulted in a complete mathematical model representing the kinematics and dynamics. The validity of the concept as well as the model are demonstrated by constructing the kinematic model into a physically viable prototype, and finally, a working device that can meet the demands of the industrial user. The path of evolution is depicted in the following flowchart (Fig. A.1), which demonstrates the iterative nature of the process.

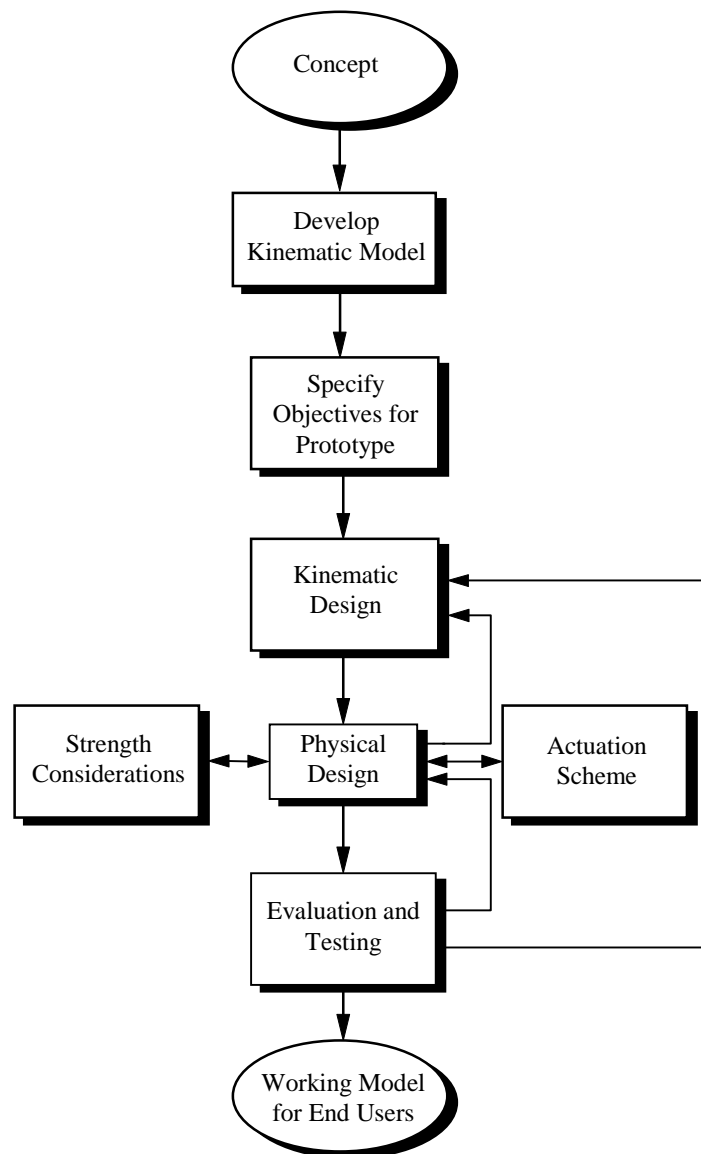

Figure A.1: Flowchart of Prototype Evolution

## Carpal Wrist Prototype Objectives

A proof-of-concept, working model of the Carpal wrist was designed and developed (Fig. A.2) to serve several roles:

- Provide the objectives for a specific, detailed wrist design.
- Provide a mechanism for testing the concept and kinematic analyses.
- Give the opportunity for application-oriented research: i.e. address real-life problems in construction of the prototype.
- Provide a demonstration tool for further insight and improvement.
- Provide a vehicle for demonstrating and marketing the idea to industry.

The mechanical design of this prototype is presented in detail by Ganino, (1996). A summary of the design and fabrication is presented here.

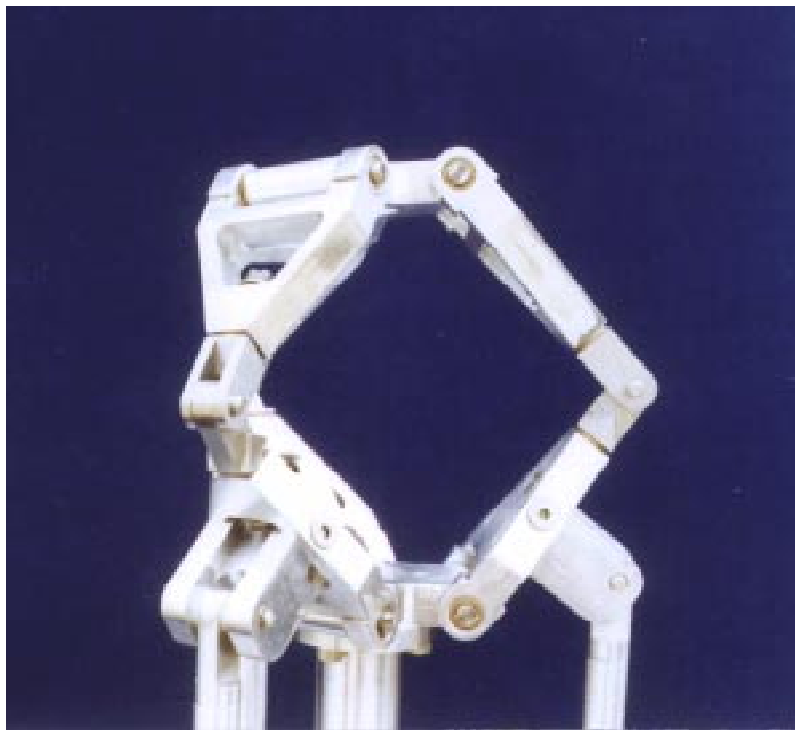

**Figure A.2: Prototype Carpal Wrist**

## Kinematic Parameters

Kinematic parameters needed in designing the wrist are the lengths of the various structural components; lengths of the bases, legs, mid-joints, and actuator members. Based on the design objectives, these are selected using the kinematic analysis tools. Canfield and Reinholtz develop a procedure for selecting these kinematic lengths (1994). In addition to a design based on kinematic analysis, physical interference constraints must also be considered. The design objectives and resulting kinematic parameters are shown in Table A.1.

Table A.1: Kinematic Parameter Selection

Design Objectives	Desired Range
<b>Size: Overall length (@ 0 deg. rotation)</b>	10 cm < Overall length < 22 cm
<b>Load Capacity</b>	> 89 N (20 lb.)
<b>Speed @ full load</b>	< 3 sec full workspace move
<b>Workspace: Spherical shell</b>	180 degree solid angle
<b>Plunge Range</b>	5 cm < $p_d$ < 10 cm
<b>Output Resolution</b>	< 0.254 mm (0.01 in.)

Resulting Kinematic Parameters	Resulting Values
<b>Length of base and distal vectors</b>	3.00 cm
<b>Length of leg vectors</b>	8.00 cm
<b>Actuation: Drive Source</b>	VEXTA PK264-02A stepping motors with Bayside NE23 (50:1) gearheads
<b>Transmission</b>	Parallel four-bar linkage

### Strength Considerations

A modified force analysis was carried out to approximate the forces that occur in the wrist under static loading to use in design for strength. In this force analysis, the wrist was modeled as a truss, with three artificial links added at the midplane nodes to represent input forces. A load was applied to the output plate of this truss and the method of joints was used to determine the forces in all links. The forces that occur at the three midplane nodes are then known; these three forces from the truss model are the same as the forces in the actual model since the mid-nodes are spheric equivalents, and carry no bending. With this information, the forces that occur in the leg, base, and mid-joint members can be determined and used in strength analysis and design.

### Actuation Scheme

Actuation is provided by controlling the three base leg angles of the Carpal wrist. The flexibility in actuating the inputs provides a distinct advantage for the following reasons;

- It allows the wrist drive motors to be located away from the wrist, closer to the robot base, ultimately allowing for higher payloads and improved dynamic characteristics.

- Power is transmitted to the joints without interference from other joints, since all links are actuated relative to ground.

There are a number of physical means for this actuation;

- Motors located on the base revolute axes, including
- Bevel or worm gear drives coming from remote motor locations.
- Linear actuators reaching from the wrist legs back along the robot arm.
- Four bar linkage connection to a remote crank-motor drive.

Selecting one of these actuation schemes depends on the nature of the robot arm and the power supply available, e.g., hydraulic, pneumatic, DC Servo, steppers, etc. The actuation form selected for the Carpal Wrist prototype: a parallel 4-bar linkage, driven by VEXTA stepping motors through a 50:1 Bayside gearhead.

### Physical Design of Components

#### Legs:

There are six identical leg components that make up the Wrist (Fig. A.2). These connect the base and distal plates to the midplane nodes through revolute bearing connections. The design issue in creating these legs, (as in designing all the critical wrist components) was in reaching a compromise between requirements of size, strength, and actuation. This issue is developed fully by Ganino (1996), and resulted in the legs shown in Fig. A.3.



Figure A.3: Leg

**Base:**

In a similar manner, the base and distal plates (Fig. A.4) were designed based on a compromise between size and strength requirements, specified in Table A.1, and the static force analysis (Ganino, 1996). The relative size of these plates made the resulting stresses low. Therefore, both the leg and base components were designed from 6061-T6 aluminum, chosen for its light-weight, strength, and excellent machining characteristics.

**Midplane Joints:**

The midplane joints, shown in Fig. A.5,

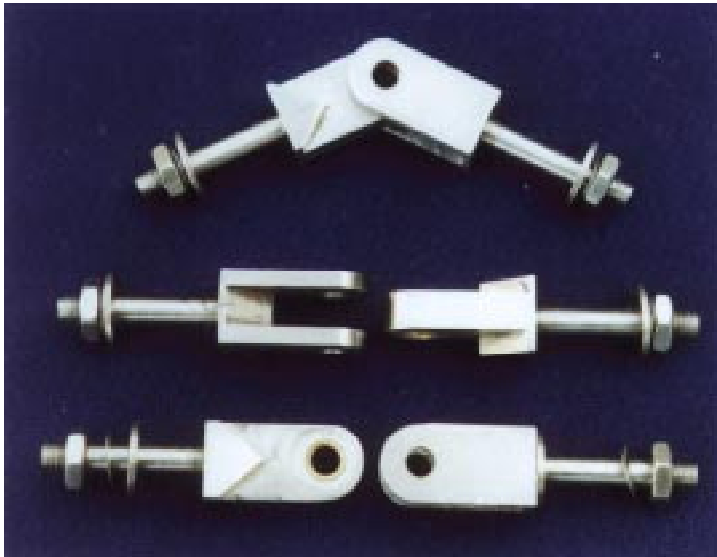

**Figure A.5: Midplane Joints**

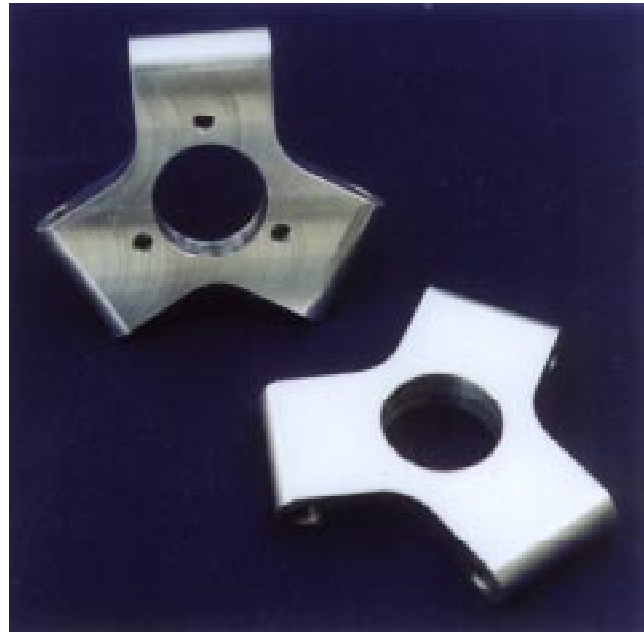

**Figure A.4: Base**

provide the three-intersecting-revolute connections required at the center of the wrist. The compromise of size and strength was critical in the design of these elements, because of their required range-of-motion and need to avoid interference. Part of the solution to this design issue is to use higher-strength materials, for example, a moderate-strength steel was employed for this joint in the Carpal prototype. In future application of this Wrist, the design of these mid-joints will be critical to overall performance.

**Actuation:**

Actuation consists of a parallel, four bar mechanism, attached to each base leg, and leading back to the motor locations (Fig. A.6). The loads carried by this actuating four bar were determined from the force control analysis and desired payload. This four-bar consisted of three specific components: the actuator insert attached to the base leg, a coupler rod, and a crank link connecting the coupler rod to the motor shaft. These components are designed based on kinematic length and strength requirements.



**Figure A.6: Actuation Components**

**Pictorial Demonstration of Carpal Prototype**

The following section summarizes the progress of the Carpal Wrist prototype. Several figures from a CAD model of the Wrist illustrate the entire prototype assembly as well as details of the individual components. A series of photographs then display the wrist deflected to several positions. A representative end-effector is placed on the distal plate of the Carpal Wrist to depict a general tool mounting. The characteristic tunnel is also demonstrated by running two hoses from the motor area through the wrist and out the distal plane. Finally, the control drivers and stepping motors are shown that provide the input joint rotation and thus control output motion.

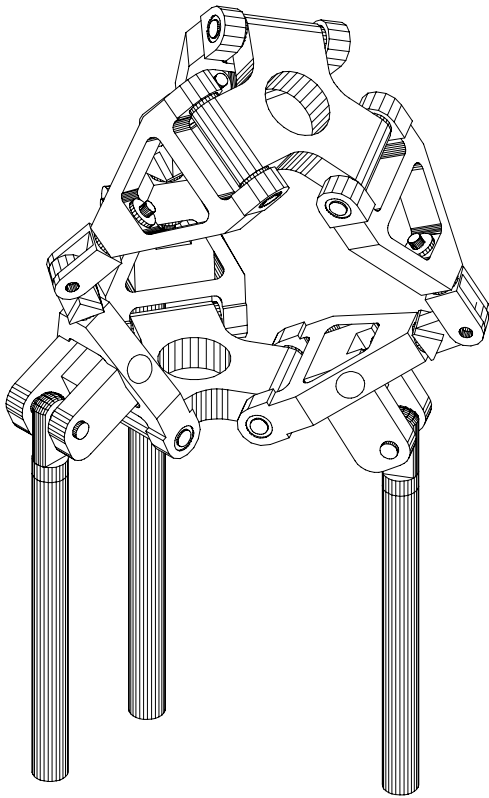

A CAD model of the prototype was generated to allow a first assessment of the design. A close-up view of the isolated wrist and the actuator rods (left) gives a check for potential interference.

A support column and three posts simulating an actual robot arm support the prototype wrist (right).

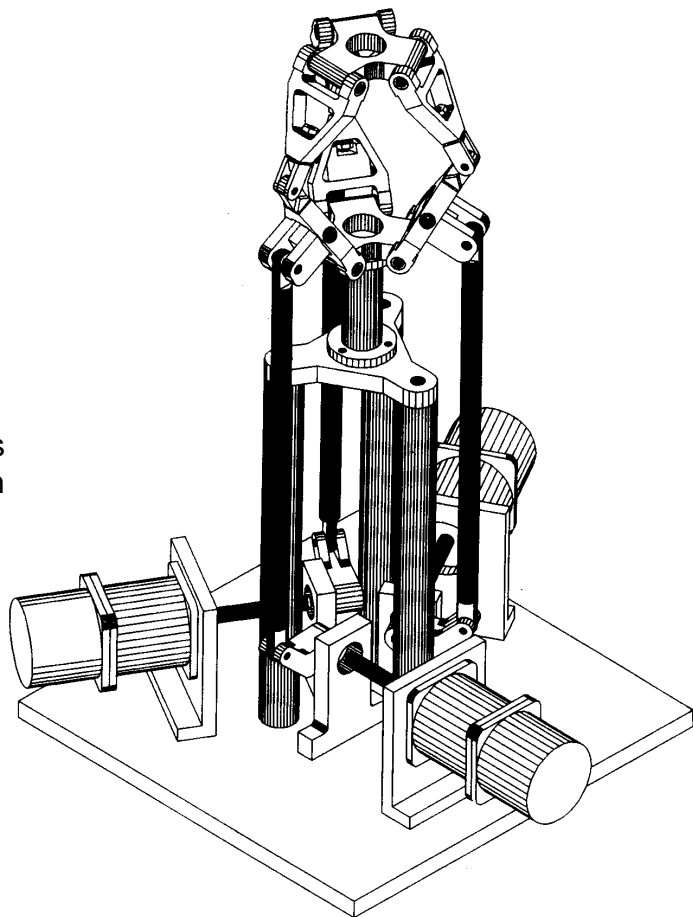

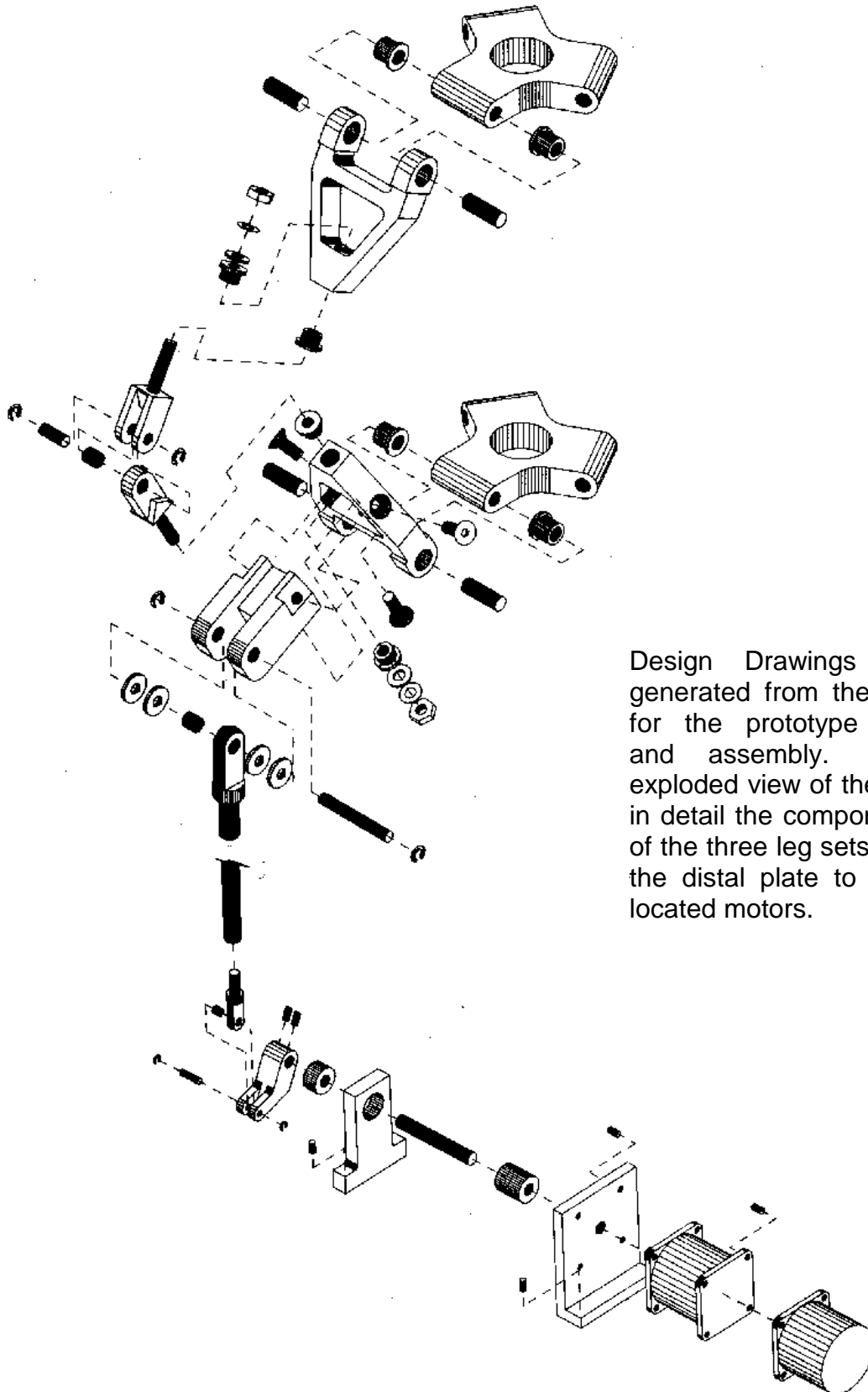

Design Drawings were also generated from the CAD Model for the prototype construction and assembly. Here, an exploded view of the wrist shows in detail the components for one of the three leg sets leading from the distal plate to the remotely located motors.

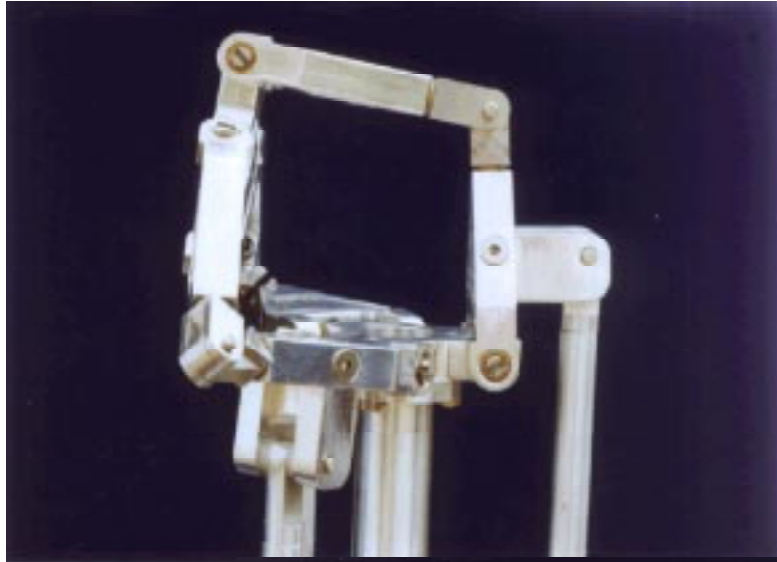

The Carpal wrist prototype contains a singularity-free workspace slightly larger than a hemisphere.

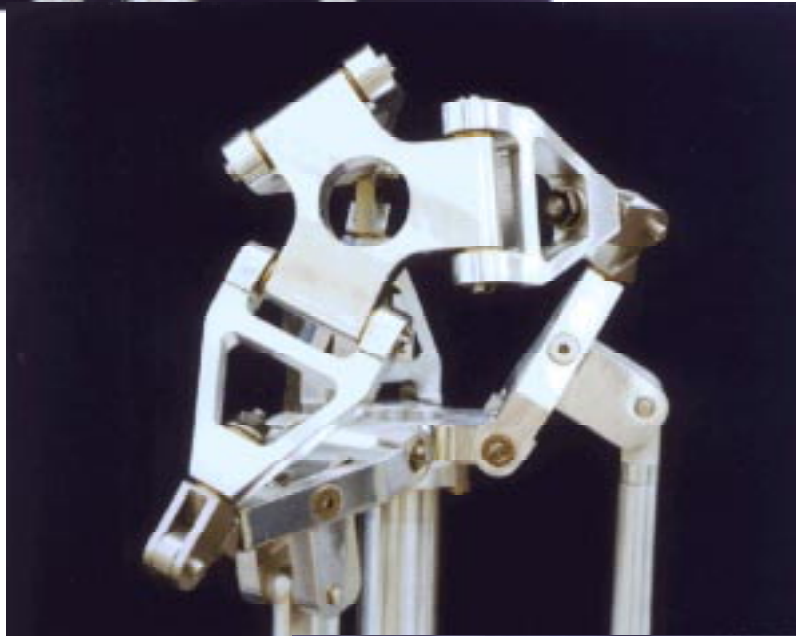

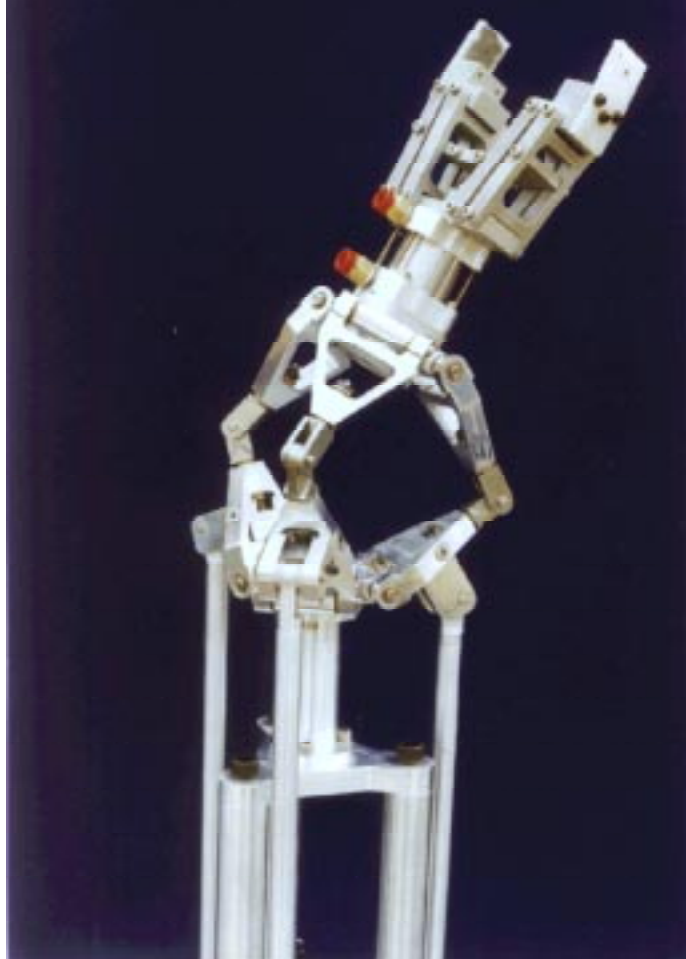
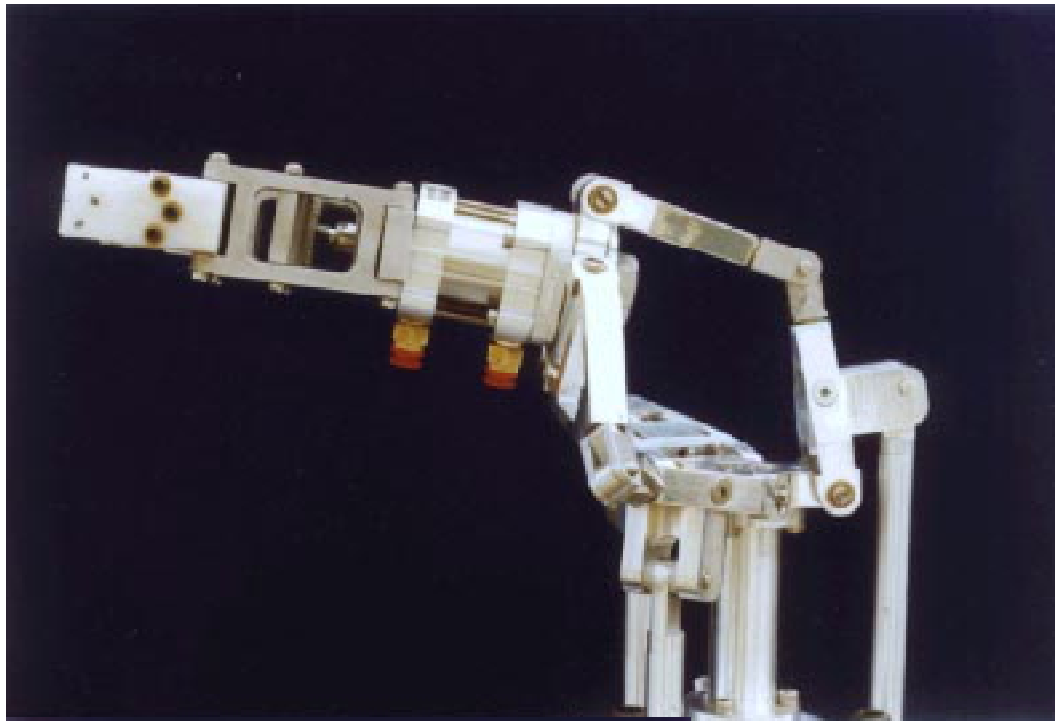

A variety of end-effectors may be mounted on the distal plate of the prototype to manipulate payloads up to 20 pounds.

The gripper shown was temporarily adapted from a puma 562 robot and is intended only to show general tool mounting.



An enclosed tunnel gives a direct, protected route for the cables, hoses, and other supply lines necessary for a specific application. This is shown from a side (right) and top (below) view.

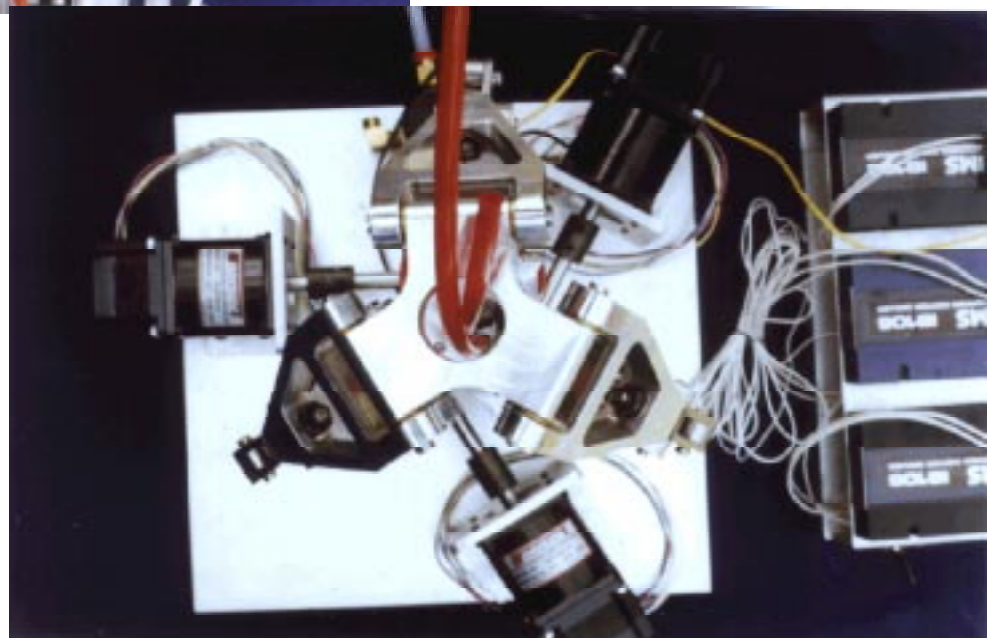

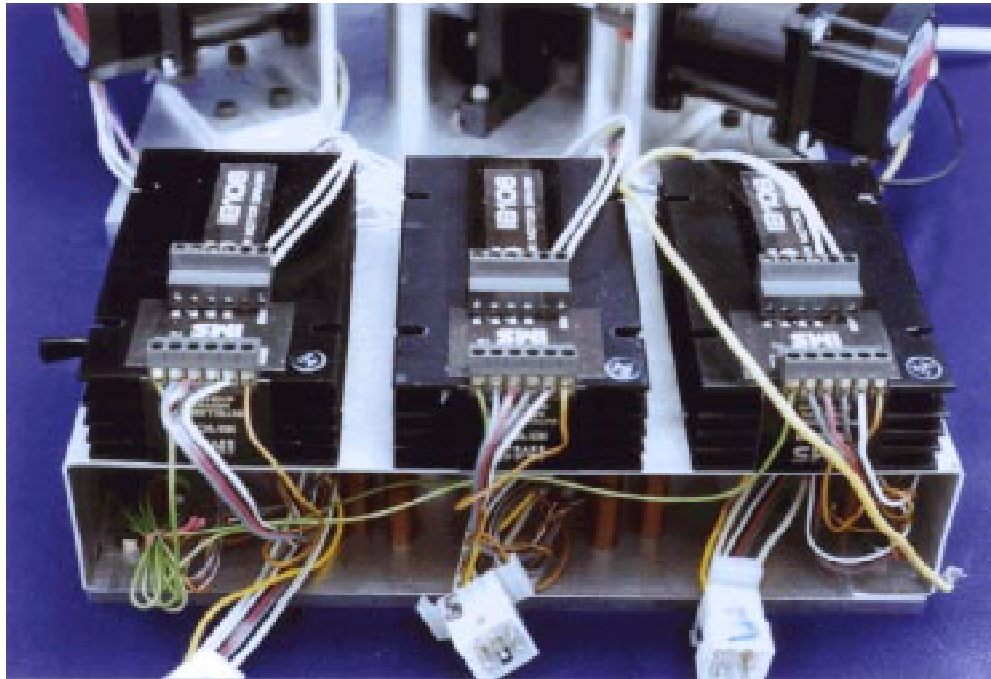

Control commands for the prototype originate in C++ kinematic algorithm code, are sent through a multi-axis stepping motor control board to a set of IMS IB106 drivers (above), and are then sent to the three VEXTA PK264-02A stepping motors with low-backlash 50:1 Bayside precision gearheads (below).

