

Chapter 1

INTRODUCTION

1.1 Introduction to Power Electronic Building Block (PEBB)

With the advent of VLSI technology, most of the present day digital systems are developed using standardized cells and components. On the other hand, modern day power systems lack a high degree of integration and standardization. In order to remedy this situation, the concept of Power Electronic Building Block (PEBB) has been developed [1].

As explained in [1],[2], the PEBB is a concept of building a large power processing system from a relatively small number of standardized units that have high degree of

intelligence and control autonomy. This results in reduced design effort, increased system reliability and reduced maintenance cost.

The most widely used converter topologies comprising a power processing system are shown in Figure 1.1. In order to exploit commonality in the power stage, the phase leg shown as the darkly shaded portion is chosen as a PEBB. These PEBBs could be combined with other components to assemble common power topologies like three phase Boost Rectifier (AC/DC), Voltage Source Inverter (DC/AC) and full bridge DC/DC converters.

The ONR (Office of Naval Research) is proposing the concept of a PEBB based DC Distributed Power System (DPS) for Navy ship electric power system [2]. Naval ships will be designed and built using common modules comprised of standard components and standard interfaces. In this new system architecture the PEBBs serve as building blocks in power generation, power distribution, energy storage, motor propulsion and integrated zonal level power conversion.

As discussed in the literature [3], [4], the DC DPS offers high power density, high efficiency and tightly regulated output voltage as needed by today's sophisticated electronic loads. PEBB based naval power systems will be large, complex and reconfigurable and would lead to significant decrease in cost.

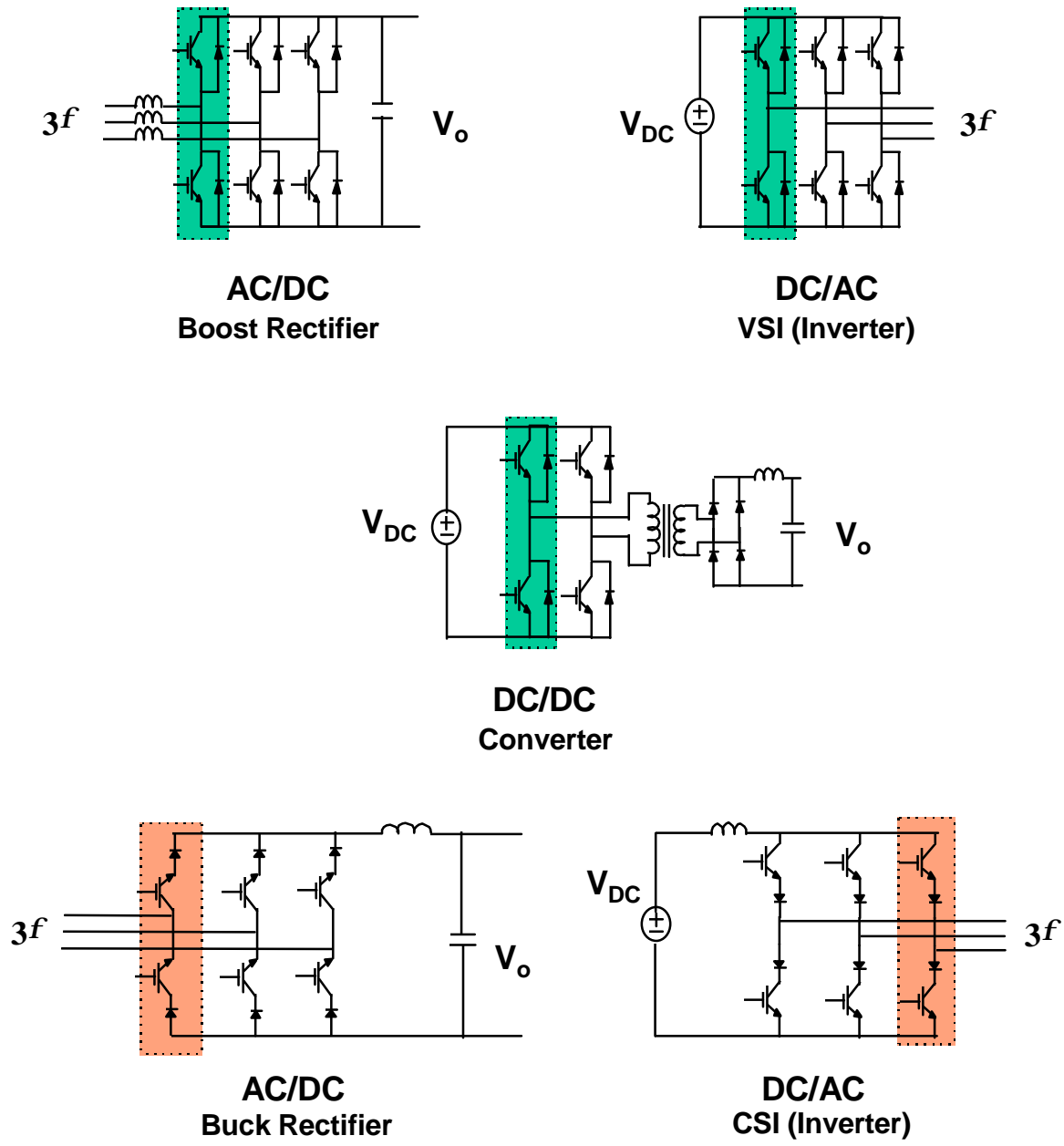

Figure 1.1 : Identification of a PEBB Switching Cell : *The commonality in the power converters is represented as the shaded block. In this thesis, the darkly shaded block is chosen as a PEBB.*

1.2 Motivation and Objective of the Research

Up to now, the work on modeling and stability analysis of DC DPS has been focused mainly on Telecommunication and Space Station power systems [3],[4]. In these applications, the DC DPS mainly comprises of DC/DC load converters and Single Phase front-end Power Factor Correction Rectifiers. DC DPS for shipboard power supply includes higher power converters like Three Phase Boost Rectifiers and Three Phase Utility Inverters. Analysis of these converters, as a stand-alone system has been discussed in the literature [5],[6],[7]. But, when these sub-systems are integrated together to form a DC DPS there are potential interaction problems which have not yet been discussed in the literature.

The objective of the research is to introduce the concept of building a large-scale power electronics system using PEBBs. Compared to the conventional system, physical system built from PEBBs offers advantages like standardization, reconfigurability and reduced cost [2],[13]. Throughout this thesis a specific DC DPS, shown in Figure 1.2 is used as an example to demonstrate the ideas presented. This PEBB based DC DPS is a simplified system configuration which emulates a part of the shipboard power system.

The DC DPS, shown in Figure 1.2, comprises of a front end power factor correction (PFC) boost rectifier supplying power to the DC bus. Various loads connected to the DC bus include a DC- DC converter and a three phase four leg Inverter. Even though the subsystems

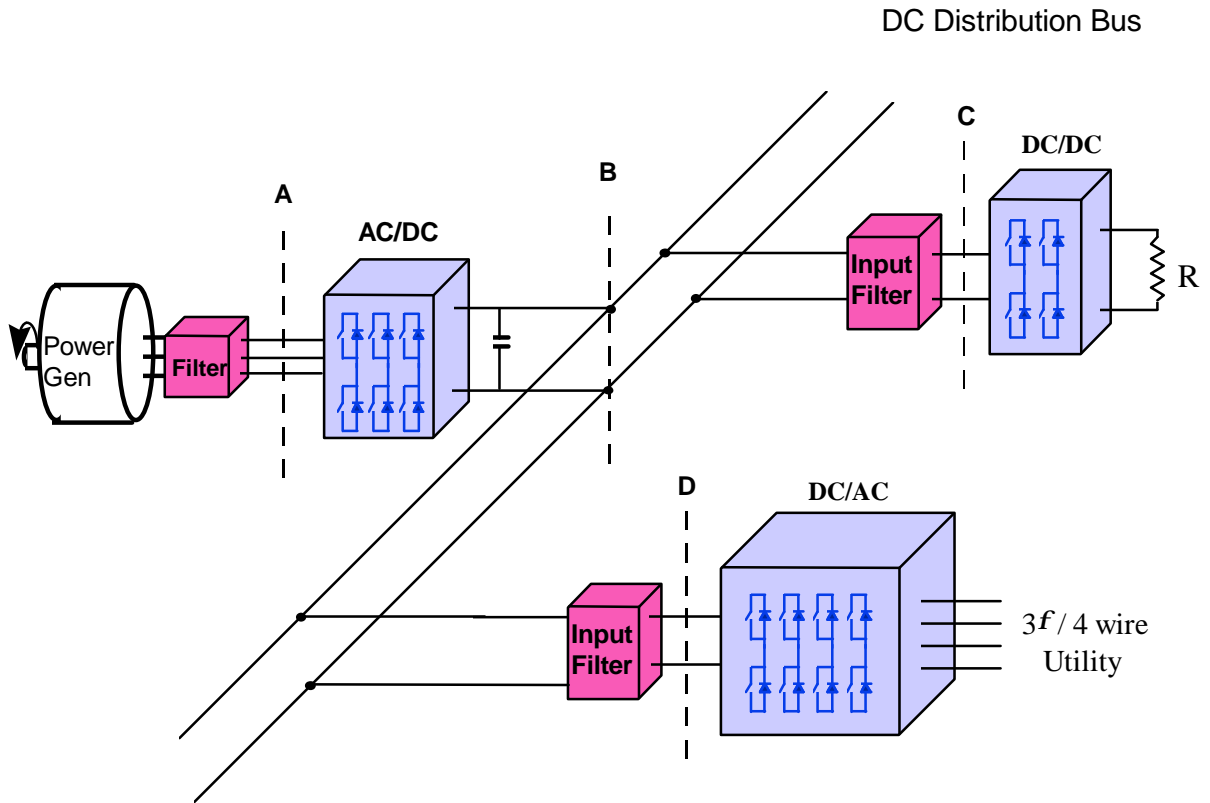

Figure 1.2 : PEBB based DC Distribution Power System (DPS) : *The DPS comprises of a front-end Boost Rectifier feeding the DC link. Various loads connected to the DC link include a three phase Four Leg Inverter and a DC-DC Converter.*

may be well designed for stand-alone operation, when these subsystems are integrated possible interactions can occur at interfaces A,B,C and D. The ability of a PEBB based DC DPS in dealing with these issues is investigated in this thesis.

Chapter 2 of this thesis addresses the issues involved in modeling the sub-systems of the DC DPS namely, the Front-end Rectifier and the Utility Inverter. A three level modeling approach is adopted. Guidelines for the control loop design of the rectifier and inverter are formulated. The performance of each sub-system is verified through simulation. The commonality in the rectifier and inverter system, built using PEBBs is used to demonstrate the generic nature of PEBBs. The fault tolerance capability of a PEBB based system is presented in this chapter. The control of the PEBB based Front End Rectifier is discussed in case of a fault condition i.e. with one of the legs of the rectifier failed open circuited.

Chapter 3 addresses the system integration issues in the DC DPS. First, the interface between each sub-system and its input filter is analyzed for stability. It is shown how an improper input filter design can effect the stability and performance of each sub-system i.e. Front-end Boost Rectifier and the Utility Inverter. Then, the interaction problems involved in incorporating the sub-systems into a DC DPS are studied. The ability of a PEBB based system in dealing with these interactions problems is discussed.

Chapter 4 presents the conclusion of this thesis.